

User Manual



MTS300 MPEG Test System Stream Creation Applications

071-0778-01

This document applies to the MTS300
MPEG Test System version 6.0 firmware.

www.tektronix.com

Copyright © Tektronix, Inc. All rights reserved. Licensed software products are owned by Tektronix or its suppliers and are protected by United States copyright laws and international treaty provisions.

Use, duplication, or disclosure by the Government is subject to restrictions as set forth in subparagraph (c)(1)(ii) of the Rights in Technical Data and Computer Software clause at DFARS 252.227-7013, or subparagraphs (c)(1) and (2) of the Commercial Computer Software - Restricted Rights clause at FAR 52.227-19, as applicable.

Tektronix products are covered by U.S. and foreign patents, issued and pending. Information in this publication supercedes that in all previously published material. Specifications and price change privileges reserved.

Tektronix, Inc., P.O. Box 500, Beaverton, OR 97077

TEKTRONIX and TEK are registered trademarks of Tektronix, Inc.

Hardware Warranty

Tektronix warrants that the products that it manufactures and sells will be free from defects in materials and workmanship for a period of one (1) year from the date of shipment. If a product proves defective during this warranty period, Tektronix, at its option, either will repair the defective product without charge for parts and labor, or will provide a replacement in exchange for the defective product.

In order to obtain service under this warranty, Customer must notify Tektronix of the defect before the expiration of the warranty period and make suitable arrangements for the performance of service. Customer shall be responsible for packaging and shipping the defective product to the service center designated by Tektronix, with shipping charges prepaid. Tektronix shall pay for the return of the product to Customer if the shipment is to a location within the country in which the Tektronix service center is located. Customer shall be responsible for paying all shipping charges, duties, taxes, and any other charges for products returned to any other locations.

This warranty shall not apply to any defect, failure or damage caused by improper use or improper or inadequate maintenance and care. Tektronix shall not be obligated to furnish service under this warranty a) to repair damage resulting from attempts by personnel other than Tektronix representatives to install, repair or service the product; b) to repair damage resulting from improper use or connection to incompatible equipment; c) to repair any damage or malfunction caused by the use of non-Tektronix supplies; or d) to service a product that has been modified or integrated with other products when the effect of such modification or integration increases the time or difficulty of servicing the product.

THIS WARRANTY IS GIVEN BY TEKTRONIX IN LIEU OF ANY OTHER WARRANTIES, EXPRESS OR IMPLIED. TEKTRONIX AND ITS VENDORS DISCLAIM ANY IMPLIED WARRANTIES OF MERCHANTABILITY OR FITNESS FOR A PARTICULAR PURPOSE. TEKTRONIX' RESPONSIBILITY TO REPAIR OR REPLACE DEFECTIVE PRODUCTS IS THE SOLE AND EXCLUSIVE REMEDY PROVIDED TO THE CUSTOMER FOR BREACH OF THIS WARRANTY. TEKTRONIX AND ITS VENDORS WILL NOT BE LIABLE FOR ANY INDIRECT, SPECIAL, INCIDENTAL, OR CONSEQUENTIAL DAMAGES IRRESPECTIVE OF WHETHER TEKTRONIX OR THE VENDOR HAS ADVANCE NOTICE OF THE POSSIBILITY OF SUCH DAMAGES.

Software Warranty

Tektronix warrants that the media on which this software product is furnished and the encoding of the programs on the media will be free from defects in materials and workmanship for a period of three (3) months from the date of shipment. If a medium or encoding proves defective during the warranty period, Tektronix will provide a replacement in exchange for the defective medium. Except as to the media on which this software product is furnished, this software product is provided "as is" without warranty of any kind, either express or implied. Tektronix does not warrant that the functions contained in this software product will meet Customer's requirements or that the operation of the programs will be uninterrupted or error-free.

In order to obtain service under this warranty, Customer must notify Tektronix of the defect before the expiration of the warranty period. If Tektronix is unable to provide a replacement that is free from defects in materials and workmanship within a reasonable time thereafter, Customer may terminate the license for this software product and return this software product and any associated materials for credit or refund.

THIS WARRANTY IS GIVEN BY TEKTRONIX IN LIEU OF ANY OTHER WARRANTIES, EXPRESS OR IMPLIED. TEKTRONIX AND ITS VENDORS DISCLAIM ANY IMPLIED WARRANTIES OF MERCHANTABILITY OR FITNESS FOR A PARTICULAR PURPOSE. TEKTRONIX' RESPONSIBILITY TO REPLACE DEFECTIVE MEDIA OR REFUND CUSTOMER'S PAYMENT IS THE SOLE AND EXCLUSIVE REMEDY PROVIDED TO THE CUSTOMER FOR BREACH OF THIS WARRANTY. TEKTRONIX AND ITS VENDORS WILL NOT BE LIABLE FOR ANY INDIRECT, SPECIAL, INCIDENTAL, OR CONSEQUENTIAL DAMAGES IRRESPECTIVE OF WHETHER TEKTRONIX OR THE VENDOR HAS ADVANCE NOTICE OF THE POSSIBILITY OF SUCH DAMAGES.

Table of Contents

General Safety Summary	vii
Preface	ix
Getting Started	
Getting Started	1-1
MTS300 Series Stream Creation Product Descriptions	1-1
Related Tektronix MTS300 MPEG Test System Components	1-4
Installation	1-9
Software Repair	1-14
First Time Operation	1-14
Operating Basics	
Operating Basics	2-1
Running the Software	2-1
Operating Basics Tutorials	2-1
Tutorial Terms	2-2
Acquiring Elementary Bit Stream Files	2-3
Creating an MPEG-2 Transport Stream File	2-7
Start the Multiplexer Application	2-7
Create a Simple Configuration File	2-7
Creating a Complex Transport Stream File	2-21
Create a Complex Configuration File	2-21
Generate a Transport Stream	2-35
Creating a Transport Stream File with DVB Information	2-39
Create a DVB Configuration File	2-39
Create a Set of Complete Tables with DVB Information	2-56
Reference	
Reference	3-1
Using the Multiplexer	3-3
Overview	3-3
The Application Window	3-5
The Hierarchic View	3-10
The Dynamic View	3-16
The Multiplexer Environment	3-20
Creating and Editing a Configuration File	3-32
Generating a Multiplex	3-84
An Example Configuration File	3-85
Using Option CA: Scrambling / Conditional Access	3-89
Activating Option CA	3-89
Creating a Stream with Scrambled Components	3-90
Using the DVB, PSIP, and ARIB Table Editors	3-93
The Application Window	3-95

Table File Operations	3-108
Table Sections	3-112
Table Items	3-116
Table Analysis	3-126
Global View	3-132
PSI, DVB SI, and ATSC PSIP Table Item Parameters	3-143
PSI and SI Table Parameters	3-144
PSIP Table Parameters	3-155
PSI Descriptors	3-163
SI Descriptors	3-169
PSIP Descriptors	3-185
Using the Jitter Adder	3-191
Application	3-191
Terms	3-191
Starting the Application	3-192
Menu Commands	3-192
Toolbar	3-198
Using the DVB Channel Coder/Decoder	3-199
Starting the Application	3-200
Menu Commands	3-201
Coding Types	3-211
Using the TMCC Stream Combiner	3-215
TMCC Information	3-216
Creating TMCC Transport Streams	3-218
Using the Error Injector	3-225
Error Injector Tutorial	3-227
Using the OpenMux Configuration Client	3-233
Overview	3-233
Real-Time Multiplexer Tutorial	3-240
Multiplexer Windows, Views, and Interface Elements	3-246
Multiplexer Inputs	3-263
Multiplexer Outputs	3-289

Appendices

Appendix A: What to Do if an Application Locks Up	A-1
Appendix B: Software Repair	B-1
Reinstalling the MTS300 Software	B-1

Glossary

Index

List of Figures

Figure 2-1: The default configuration in the application window ..	2-8
Figure 2-2: The Stream to add dialog box	2-10
Figure 2-3: The hierarchy with a video icon added to Program 2 ..	2-10
Figure 2-4: The hierarchy with the video, audio, and data icons added	2-11
Figure 2-5: The Video Stream dialog box	2-12
Figure 2-6: Error message	2-12
Figure 2-7: Details of the selected video elementary stream	2-13
Figure 2-8: Video icon and video elementary stream file	2-14
Figure 2-9: The Audio Stream dialog box	2-15
Figure 2-10: Details of the selected audio elementary stream	2-16
Figure 2-11: The display after an audio file is associated	2-17
Figure 2-12: The Data Stream dialog box	2-18
Figure 2-13: The hierarchy with the Data icon deleted	2-19
Figure 2-14: Transport stream creation is complete	2-20
Figure 2-15: The hierarchy with Programs 2 and 3 added	2-21
Figure 2-16: Elementary streams added to Program 3	2-22
Figure 2-17: The rate gauge shows an overflowed multiplex	2-23
Figure 2-18: The dynamic view of the complex.cfg configuration file	2-24
Figure 2-19: The Program Parameters dialog box for Program 2	2-25
Figure 2-20: The dynamic view after you delay Programs 3 and 4 .	2-26
Figure 2-21: The PSI period is changed to 0.01 seconds	2-27
Figure 2-22: The configuration file after changing the PSI period .	2-28
Figure 2-23: The Program Specific Information dialog box	2-29
Figure 2-24: PID Modification dialog box	2-29
Figure 2-25: The DVB Table Editor with complex.pmt loaded	2-30
Figure 2-26: Section 2 (Program 3) of the PMT	2-31
Figure 2-27: The Descriptors Selection dialog box	2-32
Figure 2-28: Registration selected	2-32
Figure 2-29: A registration descriptor added to PMT section 2	2-33
Figure 2-30: The information for the Video Stream descriptor field	2-33

Figure 2-31: The descriptor at the Elementary Stream level	2-34
Figure 2-32: Multiplex complete message	2-35
Figure 2-33: Connect locally button	2-35
Figure 2-34: Master Client application window	2-36
Figure 2-35: Assigning the Stream Player Server to I/O port two ..	2-37
Figure 2-36: Stream Player Client application window	2-37
Figure 2-37: Select Complex.trp from the File information list	2-38
Figure 3-1: Illustration of the square jitter function	3-195
Figure 3-2: Illustration of the sine jitter function	3-195
Figure 3-3: The display during jitter calculation	3-197

List of Tables

Table i: Supported applications version numbers	xii
Table ii: Tektronix MPEG Test System version 6.0 applications ...	xiii
Table 2-1: Multiplexer Hierarchic view icons	2-9
Table 2-2: EIT parameter values for sections 3 through 6	2-62
Table 3-1: Multiplexer File menu commands	3-6
Table 3-2: Multiplexer Edit menu commands	3-6
Table 3-3: Multiplexer Multiplex menu commands	3-7
Table 3-4: Multiplexer View menu commands	3-7
Table 3-5: Multiplexer Options menu commands	3-7
Table 3-6: Multiplexer Help menu commands	3-8
Table 3-7: Multiplex rate gauge colors	3-9
Table 3-8: Hierarchic view icons	3-11
Table 3-9: Default multiplexer settings	3-31
Table 3-10: Using the Add command	3-35
Table 3-11: MIP parameters	3-58
Table 3-12: MIP functions	3-60
Table 3-13: PSI / SI / PSIP Tables	3-94
Table 3-14: Table editor File menu commands	3-98
Table 3-15: Table editor Edit menu commands	3-99
Table 3-16: Table editor Section menu commands	3-100
Table 3-17: Table editor Time Span menu commands	3-100
Table 3-18: Table editor Analysis menu commands	3-101
Table 3-19: PSIP table editor Option menu commands	3-101
Table 3-20: Table editor Help menu commands	3-101
Table 3-21: Toolbar command buttons	3-102
Table 3-22: Table editor icons	3-104
Table 3-23: Table sections	3-113
Table 3-24: Items added to table sections	3-118
Table 3-25: Items added to other table items	3-119
Table 3-26: Table editor error prefixes	3-131
Table 3-27: Elementary stream types for MPEG-2 and DVB environments	3-153
Table 3-28: Channel and Event ETM id	3-157
Table 3-29: Table type values for the MGT	3-158

Table 3-30: Modulation mode values for the VCT	3-161
Table 3-31: Service type values for the VCT	3-161
Table 3-32: Component type values	3-172
Table 3-33: Expected input file types	3-199
Table 3-34: Jitter Adder menu commands	3-201
Table 3-35: TMCC basic information fields	3-216
Table 3-36: TMCC data information fields	3-217
Table 3-37: Error configuration file parameters	3-229
Table 3-38: Real-time multiplexer limits	3-234
Table 3-39: Real-time multiplexer File menu selections	3-247
Table 3-40: Real-time multiplexer Input menu selections	3-247
Table 3-41: Real-time multiplexer Multiplex menu selections	3-248
Table 3-42: Real-time multiplexer Output menu selections	3-248
Table 3-43: Real-time multiplexer View menu selections	3-249
Table 3-44: Real-time multiplexer Options menu selections	3-249
Table 3-45: Real-time multiplexer Window menu selections	3-250
Table 3-46: Real-time multiplexer Help menu selections	3-250
Table 3-47: Real-time multiplexer toolbar buttons	3-251
Table 3-48: OpenMux Spy view icons	3-253
Table 3-49: Icon type image characteristics for each possible input status	3-255
Table 3-50: PSI-SI-PSIP tables filtered by the multiplexer server .	3-265
Table 3-51: Bit rate and sampling frequency for the audio component	3-284

General Safety Summary

Review the following safety precautions to avoid injury and prevent damage to this product or any products connected to it.

Only qualified personnel should perform service procedures.

While using this product, you may need to access other parts of the system. Read the *General Safety Summary* in other system manuals for warnings and cautions related to operating the system.

Injury Precautions

Use Proper Power Cord. To avoid fire hazard, use only the power cord specified for this product.

Avoid Electric Overload. To avoid electric shock or fire hazard, do not apply a voltage to a terminal that is outside the range specified for that terminal.

Avoid Overvoltage. To avoid electric shock or fire hazard, do not apply potential to any terminal, including the common terminal, that varies from ground by more than the maximum rating for that terminal.

Avoid Electric Shock. To avoid injury or loss of life, do not connect or disconnect probes or test leads while they are connected to a voltage source.

Ground the Product. This product is grounded through the grounding conductor of the power cord. To avoid electric shock, the grounding conductor must be connected to earth ground. Before making connections to the input or output terminals of the product, ensure that the product is properly grounded.

Do Not Operate Without Covers. To avoid electric shock or fire hazard, do not operate this product with covers or panels removed.

Use Proper Fuse. To avoid fire hazard, use only the fuse type and rating specified for this product.

Do Not Operate in Wet/Damp Conditions. To avoid electric shock, do not operate this product in wet or damp conditions.

Do Not Operate in an Explosive Atmosphere. To avoid injury or fire hazard, do not operate this product in an explosive atmosphere.

Product Damage Precautions

Use Proper Power Source. Do not operate this product from a power source that applies more than the voltage specified.

Provide Proper Ventilation. To prevent product overheating, provide proper ventilation.

Do Not Operate With Suspected Failures. If you suspect there is damage to this product, have it inspected by qualified service personnel.

Symbols and Terms

Terms in this Manual. These terms may appear in this manual:



WARNING. *Warning statements identify conditions or practices that could result in injury or loss of life.*



CAUTION. *Caution statements identify conditions or practices that could result in damage to this product or other property.*

Terms on the Product. These terms may appear on the product:

DANGER indicates an injury hazard immediately accessible as you read the marking.

WARNING indicates an injury hazard not immediately accessible as you read the marking.

CAUTION indicates a hazard to property including the product.

Symbols on the Product. The following symbols may appear on the product:



DANGER
High Voltage



Protective Ground
(Earth) Terminal



ATTENTION
Refer to Manual



Double
Insulated

**Certifications and
Compliances**

Refer to the specifications section for a listing of certifications and compliances that apply to this product.

Preface

This document describes how to install and use the following Tektronix MTS300 MPEG Test System Stream Creation Applications:

- MPEG2 DVB/ATSC/ISDB-S Transport Stream Multiplexer
- DVB Table Editor
- PSIP Table Editor
- ARIB Table Editor
- Jitter Adder
- Error Injector
- DVB Channel Coder/Decoder
- TMCC Combiner
- Real-Time Multiplexer

If you purchased a Tektronix MTS300 MPEG Test System and are looking for installation instructions, first-time operation procedures, or specification information, refer to the *MTS300 MPEG Test System Hardware and Software Installation Technical Reference*, Tektronix part number, 071-0667-XX.

Manual Structure

This manual is organized into the following sections:

Getting Started. *Getting Started* describes the functional characteristics for each of the stream creation applications; lists minimum requirements for installing the software; and provides installation, configuration, and first-time operation information and procedures.

Operating Basics. *Operating Basics* provides tutorials for the multiplexer, DVB table editor, and the MTS300 MPEG Test System Stream Player Client.

Reference. *Reference* contains in-depth descriptions of the capabilities, the software interface, and configuration options for each of the stream creation applications. It also fully describes the parameters for PSI, SI, PSIP, and ISDB/ARIB tables.

Appendix A: What to Do if an Application Locks Up. Appendix A describes how to recover if the test system locks up. This appendix applies only to the Tektronix MTS300 MPEG Test System. If you have installed the stream creation

applications onto a personal computer, use the documentation that came with the computer for recovery procedures.

Appendix B: Software Repair. Appendix B contains information you might need to interpret system disk errors, inadvertent software erasures, or corrupt application files.

Glossary. The *Glossary* contains definitions of new, uncommon, and/or unique terms used in this manual.

Index. The *Index* provides a comprehensive alpha-numeric reference to the topics covered in this manual.

Manual Conventions

Typographic Conventions

Throughout this manual the following conventions apply:

- **Bold** terms are found in procedures and denote interface items that you need to select in order to cause an event to occur. For instance, to configure default directories the procedure would read as follows:

Select **Directories** from the Options menu.

In this example, even though the Options menu is an interface element, the Directories selection is the element that displays the needed dialog box (causes an event to occur) and is the only bold term in the step. When interface items are referred to outside of procedures, the terms are not boldface.

- Manual names, manual section names, and words that are defined in the text are *italicized*.
- Specific input that you need to make is indicated in the text using mono-spaced font. Unless otherwise stated, do not enter punctuation at the end of a mono-spaced font entry.

Symbols and Terminology Conventions

This manual uses symbols and terminology consistent with the following publications:

- For PSI elements, ISO/IEC Standard 11172 and 13818 (parts 1, 2, and 3)
- For DVB elements, ETSI Publication prETS 300 468
- For DVB-T elements, ETSI Publication TS 101 191 V1.2.1
- For ATSC elements, ATSC Document A/65

- For Windows elements, *The Microsoft Manual of Style for Technical Publications*, 2nd ed.

The following ARIB (Association of Radio Industries and Business) and ITU-R (International Telecommunications Union) standards were used to develop the added ARIB and TMCC enhancements to the stream creation applications:

- ARIB STD-B10 (1.2), 1999, *Service Information for Digital Broadcasting System*
- ARIB STD-B16 (1.1), 1999, *Digital Receiver Commonly Used for Digital Satellite Broadcasting Services Using Communication Satellites*
- ARIB STD-B20 (1.1), 1999, *Digital Broadcasting System and Related Operational Guidelines for Broadcasting Satellites*
- ITU-R BO. 1408, *Transmission System for Advanced Multimedia Services Provided by Integrated Services Digital Broadcasting in A Broadcasting Satellite Channel*

In cases where terms, symbols, or references are or may be ambiguous, check the *Glossary* located at the back of this manual for definitions. Also, refer to the *Glossary* for definitions unique to the MTS300 test system and applications.

Refer to the your Windows documentation for definitions and explanations of Windows specific terminology.

Related Documents

For additional information about using MTS300 software to monitor, analyze, and generate MPEG-2, DVB, and ATSC data streams, refer to the following manuals:

- The *MTS300 MPEG Test System Real-Time Analysis User Manual*, Tektronix part number 071-0658-XX, contains information about using the real-time MPEG-2 System Analyzer application.
- The *MTS300 MPEG Test System MPEG-2 DVB/ATSC System Analyzer User Manual*, Tektronix part number 071-0659-XX, contains information about using the deferred-time MPEG-2 System Analyzer.
- The *MTS300 MPEG Test System Program Stream Analyzer User Manual*, Tektronix part number 071-0662-XX, contains information about using the deferred-time Program Stream Analyzer application.
- The *MTS300 MPEG Test System Dolby Digital Audio Stream Analyzer User Manual*, Tektronix part number 071-0661-XX, contains information about using the deferred-time AC-3 Audio Stream Analyzer application.

- The *MTS300 MPEG Test System MPEG Audio Stream Analyzer User Manual*, Tektronix part number 071-0663-XX, contains information about using the deferred-time MPEG Audio Stream Analyzer application.
- The *MTS300 MPEG Test System Video Stream Analyzer User Manual*, Tektronix part number 071-0664-XX, contains information about using the deferred-time MPEG Video Stream Analyzer application.

Software Version

Table i lists the version numbers for the MTS300 MPEG Test System Stream Creation Applications supported by this manual. To verify an application version number, select **About** from the Help menu.

Table i: Supported applications version numbers

Application name	Version supported
MTS300 MPEG-2 DVB / ATSC / ISDB-S Transport Stream Multiplexer	3.08
MTS300 DVB Table Editor	2.07
MTS300 PSIP Table Editor	1.02
MTS300 ARIB Table Editor	2.10
MTS300 OpenMux	1.60
MTS300 Error Injector	1.02
MTS300 Jitter Adder	2.00
MTS300 DVB Channel Coder/Decoder	1.00
MTS300 TMCC Combiner (MTS3FTM)	2.00

Related Applications

The stream creation applications described in this manual are part of the suite of software and hardware components that comprise the Tektronix MTS300 MPEG Test System. Table ii shows the program icons for each MTS300 application, briefly describes the purposes for each application, and lists the manual name and number that you should look to for information about that test system component.

The applications that appear in the Tektronix MPEG Test System program group and Start menu depend on the system configuration and its installed options. Table ii on page xiii summarizes all test system applications available in the version 6.0 release of the Tektronix MTS300 MPEG Test System.

Table ii: Tektronix MPEG Test System version 6.0 applications



Icon	Application title	Function	User document
 Master Client	Master Client	<p>Continuously monitor an input bitstream for compliance with the MPEG-2, DVB-SI, ATSC PSIP, and ISDB/ARIB digital television standards. Use this client to start or assign to an input/output the following real-time applications and servers:</p> <p>Analysis Server, used to perform real-time analysis on a transport stream input</p> <p>TMCC Analysis Server, used to perform real-time analysis on a TMCC transport stream input</p> <p>Expert Client, used display the results of real-time transport stream analysis performed by an analysis server.</p> <p>TMCC Expert Client, used to display the results of real-time transport stream analysis performed by a TMCC analysis server.</p> <p>Configuration Client, used to configure analysis servers for specific errors.</p> <p>TMCC Configuration Client, used to configure TMCC analysis servers for specific errors.</p> <p>Stream Player, used to generate transport streams from a local file.</p> <p>Stream Recorder, used to capture transport stream input.</p> <p>OpenMux, used to configure and generate transport streams from local transport stream and elementary stream files</p>	MTS300 MPEG Test System Real-Time Analysis User Manual 071-0658-XX
 Hardware Diagnostic	Hardware Diagnostic	Perform onboard self-tests for the MPEG Test System.	MTS300 MPEG Test System Hardware and Software Installation Technical Reference 071-0667-XX (Information repeated in both manuals)
 Private Syntax Interpreter	Private Syntax Interpreter	Create table definitions used by the Real-Time Analyzer to interpret private syntax sections.	

Table ii: Tektronix MPEG Test System version 6.0 applications (Cont.)















Icon	Application title	Function	User document
 Deferred-Time Analyzer	MPEG-2 DVB/ATSC System Analyzer	Analyze transport streams and packetized elementary streams saved to the system disks.	MTS300 MPEG Test System MPEG-2 DVB/ATSC System Analyzer User Manual 071-0659-XX
 DVB Channel	DVB Channel Coding and Decoding	Code and decode transport stream files to DVB specifications.	MTS300 MPEG Test System Stream Creation Applications User Manual 071-0778-XX (Information repeated in both manuals)
 Program Stream Analyzer	Program Stream Analyzer	Analyze MPEG program stream files.	MTS300 MPEG Test System Program Stream Analyzer User Manual 071-0662-XX
 Video Stream Analyzer	MPEG Video Stream Analyzer	Analyze MPEG-1 and MPEG-2 video elementary streams files or streams extracted from the MPEG-2 System Analyzer or Program Stream Analyzer.	MTS300 MPEG Test System Video Stream Analyzer User Manual 071-0664-XX
 Audio Stream Analyzer	MPEG Audio Stream Analyzer	Analyze MPEG-1 and MPEG-2 audio elementary streams files or streams extracted from the MPEG-2 System Analyzer or Program Stream Analyzer.	MTS300 MPEG Test System Audio Stream Analyzer User Manual 071-0663-XX
 Dolby Digital Analyzer	Dolby Digital Audio Stream Analyzer	Analyze Dolby Digital (AC-3) audio elementary stream files or streams extracted from the MPEG-2 System Analyzer.	MTS300 MPEG Test System Dolby Digital Audio Stream Analyzer User Manual 071-0661-XX
 MPEG-2 Multiplexer	MPEG-2 Transport Stream Multiplexer	Create transport stream files from PSI/SI/PSIP table files, elementary stream files, and data files.	MTS300 MPEG Test System Stream Creation Applications User Manual 071-0778-XX
 DVB Table Editor	DVB Table Editor	Create and edit PSI and DVB SI table files for use with the transport stream multiplexer.	
 ATSC Table Editor	ATSC Table Editor	Create and edit PSI and ATSC PSIP table files for use with the transport stream multiplexer.	
 ARIB Table Editor	ARIB Table Editor	Create and edit PSI and ISDB ARIB table files for use with the transport stream multiplexer. You also use this editor to create and modify the SIT and DIT.	
 Jitter Adder	Jitter Adder	Add jitter to PCR data in MPEG-2 transport stream files.	
 Error Injector	Error Injector	Insert or correct errors in transport stream packets.	

Table ii: Tektronix MPEG Test System version 6.0 applications (Cont.)

Icon	Application title	Function	User document
	TMCC Combiner	Adds TMCC information to a multiplex to generate a valid ISDB-S transport stream file.	MTS300 MPEG Test System Stream Creation Applications User Manual 071-0778-XX
 License Manager	Tektronix Software Protection	Enter or reenter the general password to enable licensed applications.	Read This First, MTS300 MPEG Test System Software V6.0 071-0666-XX
 MPEG-2 Help	MPEG2_Part1 (ISO/IEC 13818-1)	The international MPEG-2 system standard in Windows Help format.	none
 Uninstall MTS	Uninstall MTS	Remove MPEG Test System software from the system disk.	MTS300 MPEG Test System User Manuals

Other Information Sources

For information about the Windows NT operating system, refer to the Microsoft documentation that accompanied your system.

For the latest information about MTS300 Series Real-Time Analyzer features and bugs, refer to the *MTS300 Series Software Version 6.0 Read This First* document that accompanied your Tektronix MPEG Test System product.

Two sources of online information are provided with the MTS300 MPEG Test System Stream Creation Applications: the application online help files and an online help file of the MPEG-2, Part 1 (Systems) document. You can access these sources of information using the following techniques:

- Access help topics by selecting **Contents** from the Help menu.
- To display the help, double click the **MPEG-2** icon in the *Tektronix MPEG Test System* program group window.

Included on the software application CD-ROM is a Read Me file for the software. This file lists the application files included with the software installation types and other important information.

The following URLs access the websites for the standards organizations listed (the URLs listed were valid as of January, 2001):

- MPEG-2 standards (International Organization for Standards)
<http://www.iso.ch/>
- DVB standards (European Technical Standards Institute)
<http://www.etsi.org/>
- ATSC standards (Advanced Television Systems Committee)
<http://www.atsc.org/>

Contacting Tektronix

Phone	1-800-833-9200*
Address	Tektronix, Inc. Department or name (if known) 14200 SW Karl Braun Drive P.O. Box 500 Beaverton, OR 97077 USA
Web site	www.tektronix.com
Sales support	1-800-833-9200, select option 1*
Service support	1-800-833-9200, select option 2*
Technical support	Email: techsupport@tektronix.com 1-800-833-9200, select option 3* 1-503-627-2400 6:00 a.m. - 5:00 p.m. Pacific time

* **This phone number is toll free in North America. After office hours, please leave a voice mail message. Outside North America, contact a Tektronix sales office or distributor; see the Tektronix web site for a list of offices.**

Getting Started

This section describes the features of the following Tektronix MTS300 MPEG Test System Stream Creation Applications:

- MPEG2 DVB/ATSC/ISDB-S Transport Stream Multiplexer
- PSIP Table Editor
- DVB Table Editor
- ARIB Table Editor
- DVB Channel Coder/Decoder
- TMCC Combiner
- Jitter Adder
- Error Injector
- OpenMux Configuration Client and Real-Time Multiplexer Server

The Tektronix MTS300 MPEG Test System software and hardware components are used to create, generate, and analyze MPEG, DVB, ATSC and ISDB-S/ARIB compliant transport streams, program streams, MPEG-1 and -2 audio and video elementary streams, and both Dolby Digital (AC-3) and AAC (Advanced Audio Coding) audio elementary streams. (Only ADTS, Audio Data Transport Stream, format is implemented for AAC elementary streams.) Using the applications documented in this manual, you can create known good transport stream files or transport stream files with known errors. Using the generation and analysis functions enabled by other MTS300 Series applications, you can then generate transport streams to test your MPEG system components.

MTS300 Series Stream Creation Product Descriptions

This section briefly describes the MTS300 MPEG Test System Stream Creation Applications. For complete information on the function and operation of each application, refer to the *Reference* section.

MTS300 MPEG-2 DVB / ATSC / ISDB-S Transport Stream Multiplexer

The Multiplexer allows you to create a limitless variety of MPEG transport stream files using the elementary streams provided on the Bit Stream CD-ROM. Up to 40 programs, with 20 elementary streams each, can be included in one transport stream file. A hierarchy display similar to the Analyzer displays the structure of the transport stream.

Elementary stream files containing both stationary test signals and motion sequences are provided on the Bit Stream CD-ROM. Using the multiplexer and table editors, you can create a variety of transport stream files that contain one or more of the provided test signals and motion sequences.

MTS300 PSIP Table Editor

The MTS300 PSIP Table Editor allows you to create and change both program specific information tables (PSI tables) and program and system information protocol tables (PSIP tables).

Program and System Information Protocol (PSIP) tables provide information (descriptive and technical) about channels and events multiplexed in transport streams and are used to enable decoders to properly decode the stream. PSIP tables also permit services to be grouped into categories with relevant schedule information and can provide information about channels and events on other physical transmission channels. For example, ATSC-compliant transport streams carried over terrestrial broadcast networks can provide information about channels and events for programs in transport streams carried over cable networks.

MTS300 DVB Table Editor

Data necessary for the DVB IRD (Digital Video Broadcasting Integrated Receiver Decoder) to automatically configure itself is available in the MPEG-2 Program Specific Information (PSI). Digital Video Broadcasting Specific Information (DVB-SI) adds information that enables DVB IRDs to automatically tune to a particular service and allows services to be grouped into categories with relevant schedule information.

Using the table editor you can enter and change data in SI and PSI tables to fit the requirements for your transport stream and environment.

MTS300 ARIB Table Editor

The MTS300 ARIB Table Editor allows you to create and change PSI and ARIB table structures and parameters.

ARIB tables that you can edit using the ARIB Table Editor include the following:

- **Broadcaster Information Table (BIT)**

The BIT provides name and ID parameters and descriptions of the services encoded in the transport stream for each broadcaster.

- **Download Control Table (DCT)**

The DCT provides a list of modules available in the transport stream for download.

- **Download Table (DLT)**

The DLT is used to download code to set top boxes.

- Software Download Trigger Table (SDTT)

The SDTT is used to define the service, group, and schedule for items encoded in the transport stream that can be downloaded.

MTS300 DVB Channel Coder/Decoder

The European Digital Broadcasting Project specifies a baseline system for satellite broadcasting. The Channel Coding portion of the specification has the following coding flow:

- MPEG-2 Transport stream file (Multiplexer)
- Energy Dispersal (randomizing)
- Outer Coder RS (204, 188, byte error correction)
- Interleaver (burst error correction)
- Inner Coder (Viterbi p/q, bit error correction)
- QPSK Modulator

This application provides the defined channel coding for the transport stream file and the decoding to return the file to a standard transport stream file.

MTS300 TMCC Combiner

The MTS300 TMCC Combiner is a wizard-like application that helps you configure TMCC information that you want added to the Reed-Solomon area of 204 byte transport stream packets. Once you specify this information, the TMCC Combiner re-multiplexes your transport stream file with the added information, creating a valid TMCC stream.

MTS300 Jitter Adder

The jitter adder allows you to create transport stream files with simulated timing errors. These errors will affect the clocks derived from the transport file. Create error-free transport streams and transport streams with known errors to test the robustness of decoders under various conditions.

MTS300 Error Injector

Using the error injector, you can introduce errors into an MPEG-2 transport stream and use the erroneous stream to stress-test MPEG-2 systems and components.

The Error Injector reads the input transport stream file, modifies selected transport packets according to instructions in a user-defined configuration file, and writes the modified stream into another file.

MTS300 OpenMux Configuration Client

This real-time multiplexer allows you to configure a maximum of 26 inputs and remultiplex all or part of them, in real time, into a valid transport stream. The following list describes the multiplexer inputs:

- MPEG-2, DVB, ATSC, and/or ISDB-S/ARIB transport streams (single or multiple program)
- Elementary streams (MPEG-2 audio and video, and AC-3 audio)
- PSI/SI/ATSC/ARIB tables (generated by the real-time multiplexer)

The OpenMux dynamically manages PID allocation among the inputs, avoiding PID collisions in the output. Using the real-time multiplexer, you can filter input transport streams for specific programs to be included in the remultiplexed transport stream. Finally, when a new transport stream is created, the multiplexer automatically regenerates program clock references.

You can output the remultiplexed transport stream using one of the rear-panel outputs on the test system. The output can be a single-shot or you can continuously loop the transport stream.

Related Tektronix MTS300 MPEG Test System Components

The MTS300 MPEG Test System Stream Creation Applications are part of the Tektronix MTS300 MPEG Test System. Related software components that comprise the full-featured MPEG test system are briefly described in this section.

Master, Expert, and Configuration Clients

The new MTS300 Series MPEG Test System client/server architecture provides unmatched analysis power and ease of use for monitoring and analyzing MPEG, DVB, and ATSC transport streams.

Master Client. The Master Client interface and functionality is similar to the Tektronix MTM300 MPEG Transport Monitor Master Client, optimized to manage the MTS300 Series clients and servers. Using the Master Client you can assign analysis servers to monitor a transport stream in real-time; you can also manage the Stream Recorder, Stream Player, and Real-Time Multiplexer servers to capture and generate transport streams on specific inputs and outputs.

The Master client provides an intuitive interface for monitoring the status of transport stream inputs. The Master client characteristics are shown in the following list:

- The Port Manager panel displays icons showing the current configuration of servers, inputs, and outputs.
- The Services panel displays icons for the services (also called programs) encoded in the monitored transport stream.
- The Details panel displays icons indicating the type, status, and severity of errors on a transport stream or service.

The Expert and TMCC Expert clients, the Configuration and TMCC Configuration clients, and the Real-Time Multiplexer (OpenMux), Stream Player, and Stream Recorder clients are all started from the Master client.

Expert Client. Start the Expert Client from the Master Client to analyze the transport stream, in real time, in greater detail. The Expert Client uses the same interface and has the same functionality as the MTS200 Series Real-Time Analyzer.

The Expert client characteristics are shown in the following list:

- Graphical displays that show the structure (hierarchy) of the input transport stream and display characteristics of each component of the input stream (for example: PID and type allocation, section rate analyses, and timing analyses).
- Report views that indicate the types of errors recorded by the Analysis Server and the characteristics of the input stream.
- Error views that show specific errors recorded for the various components of the transport stream; for instance, PMT section rate errors and ETR290 errors.
- ARIB table recognition
- AAC audio elementary stream recognition
- AC-3 audio elementary stream recognition in DVB mode
- Digicipher II video elementary stream recognition

TMCC Expert Client

The TMCC (Transmission and Multiplexing Configuration Control) Expert Client is a new application included with version 6.0 of the Tektronix MTS300 MPEG Test System. This client allows you to analyze the TMCC data of an ARIB-compliant transport stream input real time. You can also analyze an ARIB-compliant transport stream file stored on your local disk using the TMCC Deferred-Time Client.

The TMCC Expert client has the following characteristics:

- Indicates the presence of sync bytes (0x47 for TMCC basic streams and W1, W2, or W3 sync bytes for TMCC data streams)
- Displays the syntax of TMCC data
- Displays Slot, TSID, TS Name, and Modulation mode information
- Displays information, warning, and error messages

- Indicates the presence of TMCC alarm and update flags in the transport stream
- Displays the overall stream rate
- Provides access to the Stream Recorder client, enabling you to capture all or part of a TMCC transport stream input

When you use the TMCC client to analyze local transport stream files, the TMCC Configuration Client is automatically started, allowing you to specify the file you need to analyze. The toolbar for the Deferred-Time Client provides buttons with which you can navigate transitions in the TMCC data. Finally, the stream capture buttons are replaced with buttons that you can use to save all or a specific part of the transport stream file to a disk.

Configuration Client. The Configuration Client allows you to specify which transport stream parameters you want monitored, and how you want errors in your system to be reported.

The Configuration client allows you to perform the following tasks:

- Specify the standard to which you are testing an input: MPEG-2, DVB, ATSC, or ISDB
- Set, remove, or modify the probes that test transport streams for valid syntax and semantics and rates.
- Specify the way in which errors are reported in both the Expert and Master clients. You can configure each probe to report an error as Critical, Major, Minor, Warning, or as information only.
- Stop and restart an Analysis Servers running on a transport monitor.
- Set passwords on specific inputs that prevent others from changing the Analysis Server configuration for that input.
- Set parameters for capturing part of an input transport stream.

Using these applications, you can continuously monitor an input bitstream for compliance with the MPEG-2, DVB, ATSC, and ISDB-S/ARIB digital television standards. You can monitor an array of stream parameters to ensure decodability, or you can concentrate on just a few parameters for closer examination.

The Tektronix MTS300 MPEG Test System provides the a full range of program, ETR 290, multiplex, syntax, timing, and rate analyses. The results of these analyses are displayed using graphical representations of the structure of the transport stream and data flow, reports, and error messages. You can enable or disable any analysis, or set of analyses, with the exception of sync loss, which is always enabled.

TMCC Configuration Client

The TMCC (Transmission Multiplexing Configuration Control) Configuration client is a new application included with this version of the Tektronix MTS300 MPEG Test System. This client allows you to set the monitoring, analysis, and reporting parameters of the TMCC Analysis Servers.

The TMCC Configuration client has the following characteristics:

- Configures the TMCC Analysis Servers to operate in either TMCC basic or TMCC data stream modes
- Enables you to specify a transport stream ID to analyze using the MPEG-2 Analysis Server (only in the TMCC data stream mode)
- Sets parameters for the following TMCC probes:
 - Frame size
 - Super frame size
 - Modulation mode and slot consistency
 - TMCC syntax
 - TMCC update counter (only in TMCC data stream mode)

Stream Recorder and Stream Player Clients

You can capture transport streams using the Stream Recorder Client, and you can generate transport streams with the Stream Recorder using transport stream files that are local to the MTS300 MPEG Test System hardware. (Both of these clients are started from the Master Client.)

Stream Recorder Client. The Stream Recorder can be triggered to capture a section of an input based on an error detected by the analysis server, or by an external trigger.

Stream Player Client. Using the Stream Player, you can output transport stream files as a single shot or in loop mode. You can also specify ASI (both packet and byte modes) and M2S output formats.

**MPEG-2
DVB/ATSC/ISDB-S/ARIB
System Analyzer**

This deferred-time analyzer application enables in-depth analysis of MPEG-2, DVB, ATSC, or ISDB-S/ARIB transport stream files for errors in syntax, semantics, rate, timing, and other multiplex characteristics. The application uses several graphical views that provide access to each field, and each bit if you wish, in the transport packets, PES packets, and the various PSI and SI tables.

Hierarchic View. The hierarchic view provides a diagram of the data components carried by the transport stream. Icons are used to identify the PSI, SI, PSIP, and ARIB tables; PES (Packetized Elementary Stream) packets; and three types of elementary streams (video, audio, and data).

Interpreted View. The interpreted view shows all of the fields in the selected transport packet, table section, or PES (packetized elementary stream) packet.

Timing Displays. Two types of timing displays are available: PCR (Program Clock Reference) contained in the transport packet headers and PTS/DTS (Presentation/Decode Time Stamp) contained in PES packet headers. The PCRs are shown in a graphical format indicating their arrival time. The graphical display of the PTS/DTS shows a time line for each access unit (such as a video frame) indicating data arrival and value of each time stamp.

Program Stream Analyzer

With the optional MPEG Program Stream Analyzer you can view the fields and values of MPEG-2 program streams and MPEG-1 system streams at the pack and PES packet level, extract and save all or part of program and system streams, and analyze streams for coherence to the MPEG standards.

**MPEG Audio Stream
Analyzer**

With the optional Audio Stream Analyzer you can test MPEG-1 and MPEG-2 audio layer I and II specification streams. The Program Stream Analyzer or the MPEG-2 DVB/ATSC System Analyzer can extract audio elementary streams from transport or program streams and open the analyzer with the extracted elementary stream displayed.

**MPEG Video Stream
Analyzer**

With the optional Video Stream Analyzer you can test MPEG-1 and MPEG-2 video elementary streams. The Program Stream Analyzer or the MPEG-2 DVB/ATSC System Analyzer can extract video elementary streams from program and transport streams and open the analyzer with the extracted elementary stream displayed.

**Dolby Digital (AC-3) Audio
Stream Analyzer**

With the optional Dolby Digital (AC-3) Audio Stream Analyzer you can analyze and save Dolby Digital audio streams files. The Program Stream Analyzer or the MPEG-2 DVB/ATSC System Analyzer can extract AC-3 audio streams from program and transport streams and open the analyzer with the extracted elementary stream displayed.

MPEG Video Test Sequences

The Tektronix MTS300 MPEG Test System Option DT, the MTSSWO Option DT, or the MTS3FDT includes two discs that contain well-known Sarnoff Corporation MPEG video test sequences used to test MPEG components.

Installation

This section describes procedures for installing the MTS300 MPEG Test System Stream Creation Applications onto a personal computer. If you are installing the software on a Tektronix MTS300 MPEG Test System, refer to the *MPEG Test System Hardware and Software Installation Technical Reference* (included with the test system) for instructions. You can also use this procedure to reinstall software if it is deleted or corrupt.

Installation includes three separate processes:

- Attach the software key to the parallel printer port of your computer.
- Install required program files and sample files using the installation wizard.
- Enter your license password, which enables you to run the installed applications.

Before you install the stream creation applications, ensure that your system meets the minimum hardware and software requirements.

Minimum Requirements

You can install the stream creation applications on a personal computer with the following minimum requirements:

- 150 MHz Intel Pentium processor
- 32 MB RAM
- 140 MB free disk space (for MTS application software) plus adequate space for transport stream test files.
- CD ROM drive (for software installation)
- Windows NT 4.0 (Service Pack 6) operating system
- 1024 x 768 pixel video monitor with 256 available colors

Software Key

Attach the software key (shown in the following illustration) to the parallel printer port of your computer. MTS300 Series applications do not run without the software key installed.

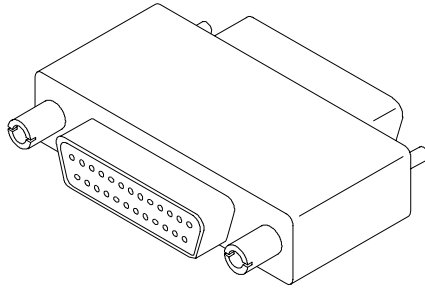

To use the printer port with the software key installed, attach printer cables directly to the software key. The software key will not interfere with parallel communications.

NOTE. To run MTS300 MPEG Test System Stream Creation Applications, the software key must be installed on the computer parallel printer port. Do not remove or misplace the software key.

Installing Software

If you are installing the stream creation applications on a personal computer, use the procedures described in this section. The minimum hardware and software requirements for installing the stream creation applications are described in *Minimum Requirements* (see page 1-9).

1. Install the software key as described in *Software Key*.

NOTE. If you have just uninstalled an earlier version of the MTS300 software, ensure that you have rebooted your PC before starting this procedure.

2. If your system requires a user name and password, log on to Windows NT as Administrator, using MPEG2 as the password (the default auto-login for the MTS300 system).
3. Right-click the **My Computer** icon on your desktop, and then select **Explore** from the resulting submenu. In the Exploring window, select the icon that represents the disk drive onto which you will install the software (usually drive C:).

4. Check the status bar at the bottom of the Exploring window to verify that the target disk has at least 140 Mbytes of free space. You cannot install the software on a disk with less than 140 Mbytes of free space.

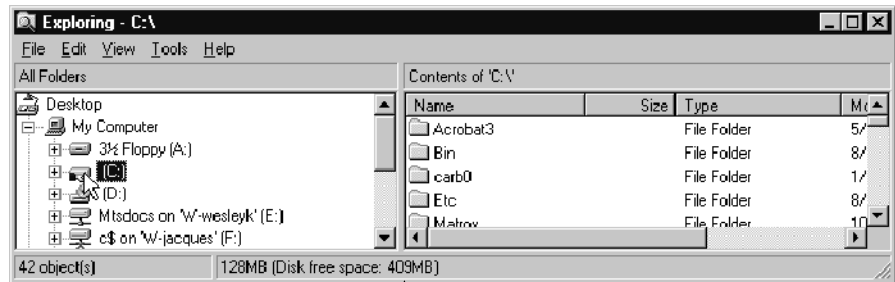

5. Place the *MTS300 MPEG Test System Software Recovery CD* into the CD-ROM drive.
6. Click the Windows NT **Start** button and select **Run...** from the submenu.
7. Enter `d:\Setup.exe` in the resulting Run window as depicted in the following illustration. In this example, *d* is the drive letter for the CD ROM drive; use the drive letter that is correct for your computer.
8. Click **OK** to start the software installation.
9. In a few seconds, the Tektronix MTS300 Series window appears on the computer screen.
10. Read the Copyright and Setup text and click **Next** to proceed to the Choose Destination Directory window.
11. The default destination folder is `C:\Mts300`. Click **Next** to accept the default folder.

NOTE. *It is strongly recommended that you use the default destination folder.*

12. The Setup Type window opens. Select **MTS Software Only Products**, and then click **Next**.

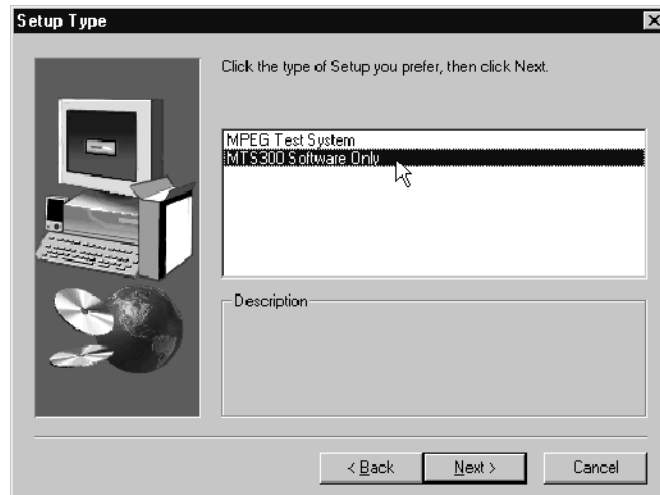

13. The Select Program Folder window opens. Click **Next** to accept the default folder name (Tektronix MPEG Test System) and continue.
14. Review the Destination Directory, System Product, and Start Menu Folder selections in the Selection Summary window. If the selections are incorrect, click **Back** and change the information as needed. Once the information is correct, click **Next** to proceed with installation.

The setup program begins installing the software and related files. The activity and progress gauges appear at first to show that the installation is progressing. Installation proceeds without your input (and sometimes with no apparent activity) for approximately 2 1/2 minutes, depending on your computer.

15. During a normal setup, the computer displays two empty program group windows after it copies the program files to your disk drive. After the windows appear, a message reminds you to verify that the software key is installed.
16. Verify that the software key is installed on the parallel (printer) port as described in *Software Key* on page 1-10; then click **OK**.

17. The Setup Complete window opens; click **Finish** to continue.
18. A Notepad window opens to display the Readme file. Scan the text for important information, and then select **Exit** from the File menu to close the window.
19. Another Setup Complete window opens. Accept *Yes, I want to restart my computer now*.
20. Remove the test system software installation disk from the CD ROM drive and click **Finish** to complete the setup and reboot the system.

Entering the General License Password

Perform the remaining steps to enter the general password that corresponds to the attached software key. Doing so enables the applications that are included with your MTS300 MPEG Test System product.



License Manager

1. Double-click the **License Manager** icon to start the application. The Tektronix Software Protection window appears.



2. Consult the password document supplied with your software and identify the general password.
3. Enter the three 6-character hexadecimal numbers of the password in the corresponding Tektronix Software Protection window entry fields (lowercase characters are acceptable).
4. Click **OK**. A License message window appears.
5. If the password is correct, click **OK** to acknowledge the message. If you made an error entering the password, click **OK** and return to step 3.

When you enter the correct password, software installation is complete. You will need to restart the computer before you can start any of the stream creation applications.

Software Repair

If you experience operating problems following installation of application software or if the system becomes corrupt, refer to *Reinstalling the MTS300 Series Software* in *Appendix B* of this manual.

First Time Operation

As noted in the headings of this section, some of the following procedures apply only if you are using the Tektronix MTS300 MPEG Test System. See your computer user documentation for similar procedures if you are using a personal computer/workstation.

This section describes the following procedures:

- Turning on the Tektronix MTS300 MPEG Test System
- Logging on to the Tektronix MTS300 MPEG Test System
- Starting the applications for which you have a license password
- Exiting the applications
- Shutting down the Tektronix MTS300 MPEG Test System

Turning on the MTS300 Series MPEG Test System

To power on the MTS300 MPEG Test System computer, press the power switch.

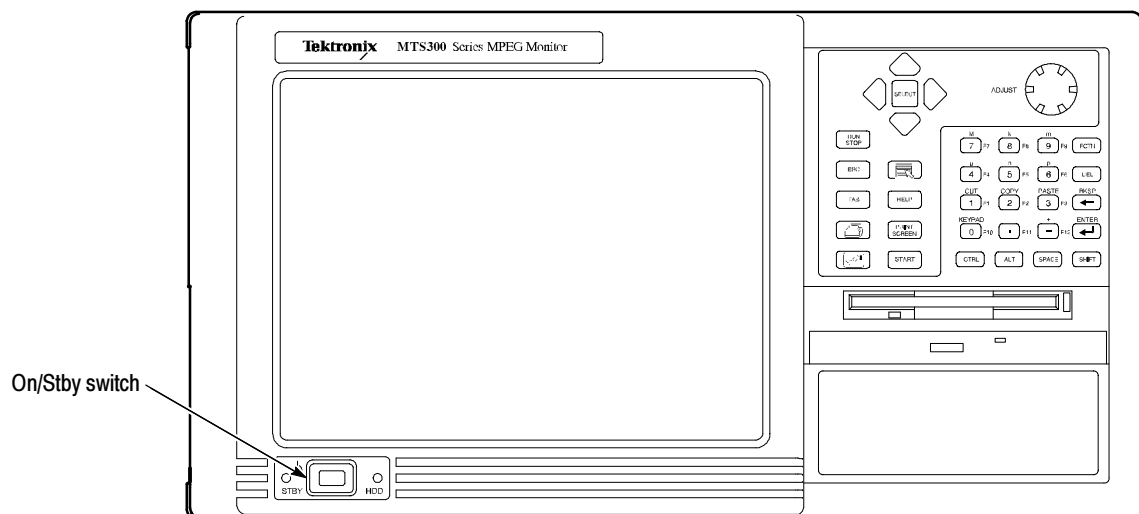

The Windows NT initialization process takes up to two minutes to complete. Under normal circumstances, no action is required. (For further information on the Windows NT initialization process, see the Windows NT online help included with the test system.) When the Begin Logon window appears, simultaneously press the **CTRL + ALT + Delete** keys to open the Logon Information dialog box.

Logging On to the MTS300 Series MPEG Test System

The MTS300 system is configured to auto-logon using the Administrator user name and MPEG2 password. You should not need to log on to NT unless you have changed the default characteristics.

Changing Passwords. You can change passwords at this time. See the Windows NT documentation for instructions. If you change any password, be sure to create a new emergency repair disk as explained in *Appendix B: Software Repair*.

Starting Applications

After you have logged on, the Tektronix MPEG Test System program group window appears as shown below. Start the applications by double-clicking the appropriate icon (refer to Table ii on page xiii for descriptions of the various icons and the applications each represents).

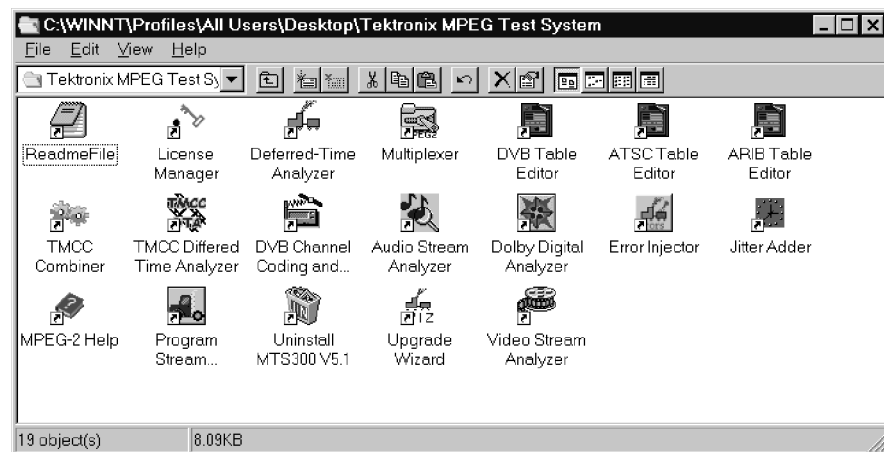

Exiting Applications

To exit the stream creation applications, select Exit from the File menu or click the close box in the upper-right corner of the application window. The current configuration is preserved and used the next time you start the application.

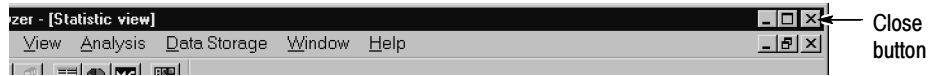

In the default configuration, application information and error messages (up to 2048 kbytes) are automatically saved in the Windows NT Event Viewer. No additional information is saved.

Shutting Down the Tektronix MTS300 MPEG Test System

To avoid loss of data and possible problems during subsequent Windows NT initialization, always shut down Windows NT before switching the computer power off. To shut down Windows NT, use the following procedure:

1. Select **Shut Down** from the Start menu.



2. In the Shut Down Windows dialog box, select **Shut down the computer?**, and then click **Yes**.



CAUTION. Do not switch the computer power off until after the following message appears: *It is now safe to turn off your computer. Turning your computer power off before this message appears can cause you to lose data and may make restarting Windows NT more difficult.*

After a few seconds, the Shutdown Computer window appears with the following message: *It is now safe to turn off your computer.*

3. Press the power switch on the front of the computer to turn the computer off (see the illustration on page 1-14).

Operating Basics

Operating Basics provides a functional overview of the MTS300 MPEG Test System Stream Creation Applications and tutorials in which you create transport stream files using the following applications:

- MTS300 MPEG-2 DVB / ATSC / ISDB-S Transport Stream Multiplexer
- MTS300 DVB Table Editor

You will also learn how to output a transport stream using the MTS300 MPEG Test System Stream Player Client.

You will find operating information about the remaining stream creation applications and more detailed information about the multiplexer and table editors in the *Reference* section of this manual.

Running the Software

Start stream creation applications by double-clicking the appropriate icon in the Tektronix MPEG Test System program group window. The software key and passwords must be installed for the applications to operate (see *Installing Software* on page 1-10 for additional information).

NOTE. *This manual is written assuming a basic level of familiarity with the Windows NT 4.0 operating system. If you are not comfortable with this environment, see your Windows NT online help.*

Operating Basics Tutorials

The three tutorials in this section will help you become familiar with the MTS300 MPEG-2 DVB / ATSC / ISDB-S Transport Stream Multiplexer, the MTS300 DVB Table Editor, and, if installed, the MTS300 Series Stream Player.

The first tutorial, which begins on page 2-7, shows you how to create a simple MPEG-2 configuration file. The tutorial then shows you how to multiplex the transport stream file using the configuration file you create.

The second tutorial (beginning on page 2-21), extends the first tutorial and shows you how to create a more complex configuration file and transport stream file. It also shows you how to output the transport stream file as a transport stream, provided you are using a Tektronix MTS300 MPEG Test System.

The third tutorial (beginning on page 2-39), shows you how to create a configuration file and a transport stream file with DVB components.

The tutorials were created using the Tektronix MTS300 MPEG Test System; however, you can perform most of the tutorial without a test system. The video, audio, and table template files required to work through these tutorials are installed on your hard disk when the MTS300 Series program files are installed.

Tutorial Terms

The following list defines some common terms used in the three tutorials provided in this section:

- In this tutorial, *multiplex* refers to the process the multiplexer uses to create a transport stream file. Transport stream files are multiplexed using the information included in the configuration file and other referenced files (PSI/SI/PSIP/ARIB tables and elementary streams).
- Since transport stream files can be very large, they are not generated immediately. Instead, configuration files (*.cfg) are created first. A *configuration file* is a text file that you create using the multiplexer. The configuration file lists various multiplex parameters and provides references to the table files and the elementary stream files that you specify as you create the configuration file. The multiplexer uses these parameters and referenced files to generate (multiplex) transport stream files.

For further information on how configuration files work, refer to *File Conventions*, beginning on page 3-3. To see what a typical configuration file looks like, see *An Example Configuration File* on page 3-85.

- A *transport stream file* is a file on your disk that you create by multiplexing the tables and elementary streams referenced in your configuration file using the rates and other parameters indicated in your configuration file.
- A *transport stream* is a transport stream file that is properly timed and output using one of the rear-panel connectors on the back of the Tektronix MTS300 MPEG Test System.

Acquiring Elementary Bit Stream Files

The standard configuration MPEG Test System includes sample video and audio elementary stream files and a sample transport stream file. These files contain pictures, common industry test signals, and sample signals in MPEG-2 format. Use the files as example formats for the tutorials and to construct your own sample transport streams.

Two additional sources of elementary stream files are available: three CD-ROM discs, which are supplied with the MTS300 Deferred-Time products (MTS300 Option DT, the real-time test system with deferred-time analysis capability; MTS3FDT, an upgrade; or MTSSWO Option DT, a software only product), and the Tektronix FTP site. Two of the CD-ROM discs (STRM100 and STRM101) contain well-known Sarnoff Corporation MPEG video test sequences. There are test sequences for both NTSC and PAL broadcast environments on these two discs. (See the manual that accompanies the Sarnoff discs for further information, Tektronix part number 070-9644-xx). The following sections describe the contents of the third disc (Tektronix part number 063-1914-xx) and the Tektronix FTP site.

MPEG-2 Elementary Streams CD-ROM

To access the elementary stream files on the CD-ROM, either copy the files to the appropriate directories on the MTS300 Series system disk (drive C) or leave the CD-ROM in drive D.

Audio Files. The CD-ROM contains the following audio files in the Audio directory:

15kz_064.mp2	4kz_064.mp2
15kz_128.mp2	4kz_128.mp2
15kz_192.mp2	4kz_192.mp2
15kz_256.mp2	4kz_256.mp2
1kz_064.mp2	Music064.mp2
1kz_128.mp2	Music128.mp2
1kz_192.mp2	Music192.mp2
1kz_256.mp2	Music256.mp2
400_064.mp2	Sync_064.mp2
400_128.mp2	Sync_128.mp2
400_192.mp2	Sync_192.mp2
400_256.mp2	Sync_256.mp2

The file names indicate the elementary stream bit rate. For example, the file 15kz_256.mp2 contains a 15 kHz audio tone at 0.256 Mbps.

Video Files. The CD-ROM contains the following video files. The Video\525 directory contains streams with 525-line video; the Video\625 directory contains streams with 625-line video. Both directories contain all listed files.

100b_015.mp2	Mulb_120.mp2
100b_060.mp2	Pulb_015.mp2
100b_120.mp2	Pulb_060.mp2
Bbc3_015.mp2	Pulb_120.mp2
Bbc3_060.mp2	Sync_015.mp2
Bbc3_120.mp2	Sync_060.mp2
Cact_015.mp2	Sync_120.mp2
Cact_060.mp2	Tens_015.mp2
Cact_120.mp2	Tens_060.mp2
Mobl_015.mp2	Tens_120.mp2
Mobl_060.mp2	V700_015.mp2
Mobl_120.mp2	V700_060.mp2
Mulb_015.mp2	V700_120.mp2
Mulb_060.mp2	

The file names indicate the elementary stream bit rate. The file 100b_060.mp2, for example, contains a video elementary stream with a bit rate of 6.0 Mbps.

Examples. The CD-ROM also contains the following files in the Examples directory:

10khz.mp2	Demo_060.mp2
1khz.mp2	Sample.trp
Demo_015.mp2	

The MPEG Test System FTP Site

You can access the same signals (and any new bit streams that become available) via anonymous FTP from the Tektronix FTP site, ftp.tek.com. If you have a web browser, go to the following URL:

```
FTP://ftp.tek.com/tv/test/streams/Element/
```

Or, use FTP to contact ftp.tek.com. Log in as “anonymous” and use your email address as the the password. MPEG files are available in the subdirectories of /tv/test/streams/Element. Each directory contains a Readme.txt file that describes its contents.

The following script illustrates the procedure for connecting to the MPEG Test System FTP site using a command line interface. The entries you need to make are indicated with bold face type. Remember to transfer data in binary mode.

```
% ftp ftp.tek.com
Connected to inet1.tek.com.
220 inet1 FTP server (Version wu-2.4(1) Sun Jan 29 12:29:00 GMT
1995) ready.
Name (ftp.tek.com:user): anonymous
331 Guest login ok, send your complete e-mail address as
password.
Password: enter your email address
230-
230- T E K T R O N I X F T P A R C H I V E
/
230 Guest login ok, access restrictions apply.
ftp> cd /tv/test/streams/Element
250 CWD command successful.
ftp> get README.TXT
```

The data included in this FTP site distribution is available to you on an “as-is” basis. Tektronix disclaims any and all warranties, whether express, implied, or statutory, including any implied warranties of merchantability or of fitness for a particular purpose.

If you do not have access to the FTP site, or cannot use FTP, contact Tektronix at 1-800-TEK-WIDE and ask for MPEG Test System support. A Tektronix representative will help you obtain the data.

Creating an MPEG-2 Transport Stream File

This section explains how to create a simple MPEG-2 transport stream file. The tutorial will show you how to perform the following tasks:

- Start the multiplexer
- Create and save configuration files
- Add elementary streams to configuration files
- Multiplex transport stream files

See *Tutorial Terms* on page 2-2 for definitions of terms used in this tutorial.

Start the Multiplexer Application

Double-click the Multiplexer icon in the Tektronix MPEG Test System program group window to start the application.

Create a Simple Configuration File

1. Choose **New** from the File menu (or click the **New** button on the toolbar).
2. Enter the name *simple* in the File Name text box (the *.cfg extension is added automatically), and then click **OK**.

Multiplexer Application Window

The Multiplexer application now displays the default configuration file. (See Figure 2-1.) The application window has three parts: the Duration gauge, at the top of the display; the Multiplex Rate gauge, at the left of the display; and the Hierarchic View, at the right of the display. Each part is explained in the following three sections (use Figure 2-1 to locate each part of the multiplexer application window).

See *Using the Multiplexer* beginning on page 3-3 for more information about the Multiplexer application window elements.

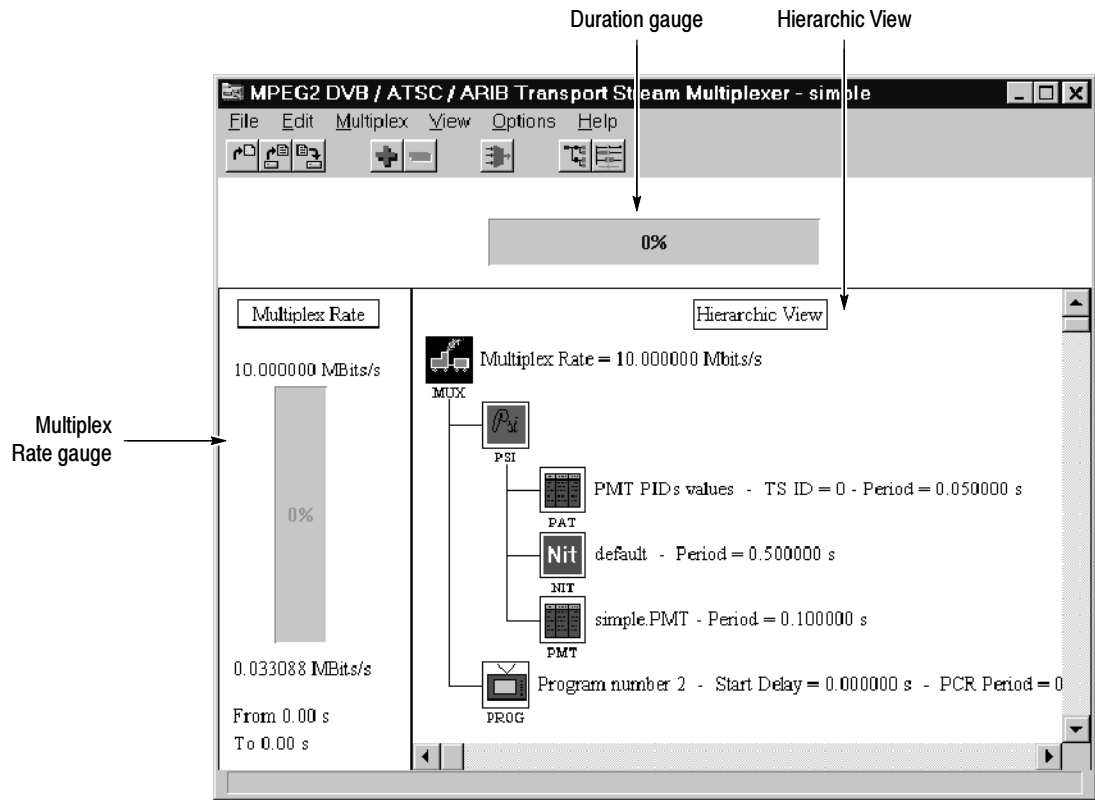

Figure 2- 1: The default configuration in the application window

Duration Gauge. The Duration gauge shows the status of the multiplex operation. The gauge displays 0% until you begin to create a transport stream file. Once you start multiplexing a transport stream file, the gauge tells what percentage of the multiplex operation is complete.

Rate Gauge. The Rate gauge graphically shows the percentage of the available transport stream currently used. The value displayed above the rate gauge is the maximum target multiplex rate. The value displayed below the rate gauge is the maximum actual multiplex rate for the time frame indicated at the very bottom of this section.

The actual rate is calculated using the following formula:







$$\text{Actual rate} = \text{PSI rate} + \text{Video rate} + \text{Audio rate} + \text{Data rate}$$

For configuration files using SI, PSIP, MIP, and ARIB information, add the SI, PSIP, MIP, and ARIB rates.

Below the actual rate is the time period when the highest multiplex rate occurs.

Hierarchic View. The Hierarchic View displays the current configuration file in hierarchic form. Several icons, which represent specific elements of the multiplex, appear in this part of the multiplexer window. These icons are explained in Table 2-1. (For a complete list of the multiplexer Hierarchic view icons, see *Hierarchy Icons* on page 3-10.)

Table 2-1: Multiplexer Hierarchic view icons

Icon	Meaning
 MUX	Multiplex. The main icon for the configuration file. Required.
 PSI	Program Specific Information (PSI). Contains the data that allows the demultiplexing of the programs by decoders. Required.
 PAT	Program Association Table (PAT). The main PSI table. It links the program numbers and the Program Map Table (PMT) PID. Every transport stream must have a PAT that is always PID 0. This table is required to identify the PID numbers for the table(s) defining each program. Required.
 PMT	Program Map Table (PMT). Specifies the PID values and describes the program components. There is a PMT for every program in the transport stream. The table states the PID for each elementary stream associated with a specific program. There are no specific PID values for PMTs in the MPEG-2 standards, however certain transmission systems (such as ATSC and DVB) require specific values. Required.
 NIT	Network Information Table (NIT). Provides information about the physical network.
 PROG	Program. Allows you to set the program start delay and PCR period values. Required. Each transport stream is required to have at least one program with one elementary stream. Note that the program numbering starts at two to avoid conflicts between the NIT table ID and the ATSC program paradigm (the PMT PID for a program one would be the same as the NIT PID).

Add Elementary Streams

The simplest transport stream possible would have one program with one elementary stream in it. In this tutorial, you will put two elementary streams in one program.

Add elementary stream icons to Program 1.

1. Select the **Program 1** icon.
2. Click the **+** (Add) button on the toolbar (or select **Add** from the Edit menu). This opens the dialog box shown in Figure 2-2.



Figure 2-2: The Stream to add dialog box

3. Check the **Video** option, and then click **OK**. This adds a Video icon to Program 1 as shown in Figure 2-3.

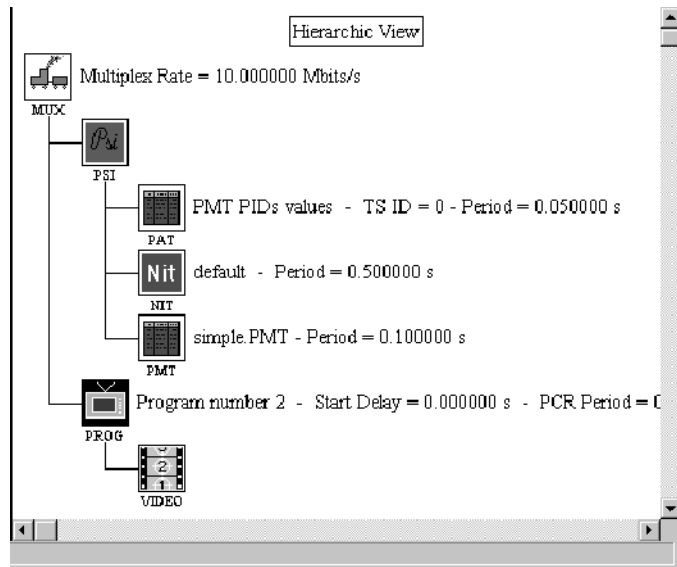

Figure 2-3: The hierarchy with a video icon added to Program 2

4. Repeat this procedure (click **+** on the toolbar, select a type of stream, and click **OK**) twice to add an Audio icon and a Data icon to the hierarchy. The completed Hierarchic view resembles Figure 2-4.

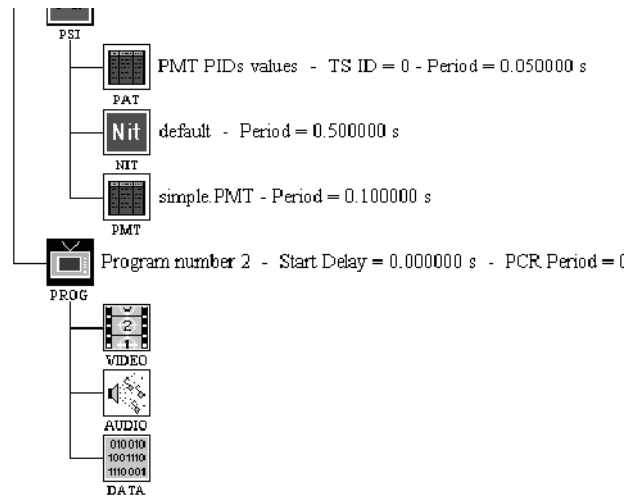

Figure 2-4: The hierarchy with the video, audio, and data icons added

Notice that there is no information alongside the three elementary stream icons. This is because you have not yet indicated which elementary stream files you will use in your multiplex (associated a file with an icon). In the next procedure, you will associate elementary stream files with the video, audio, and data icons.

Associate a video elementary stream file with the Video icon.

1. Double-click the Video icon. This opens the Video Stream dialog box shown in Figure 2-5 on page 2-12.
2. Click the **Browse** button. This allows you to select a video elementary stream from existing files using the Video Stream Selection dialog box.
3. Select **C:\MTS300\VIDEO\625\MOBL_060.MP2** and click **OK**.

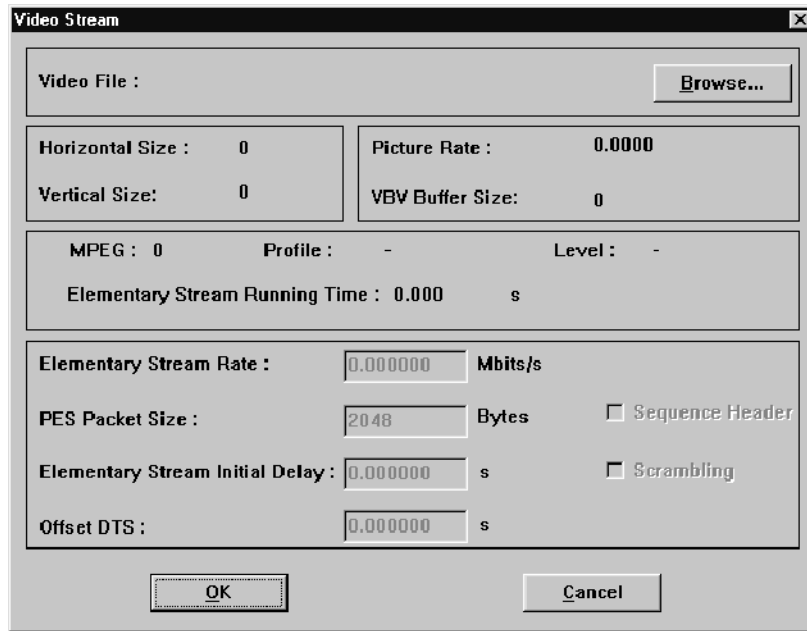

Figure 2-5: The Video Stream dialog box

NOTE. The List Files of Type box in the Video Stream Selection dialog box does not specify the *.mp2 file extension. However, you can only use *.mp2 files as video elementary stream files. If you select an unacceptable file, you will see the message box shown in Figure 2-6.

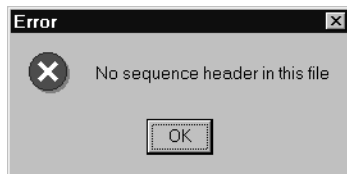

Figure 2-6: Error message

4. If you see the error message shown in Figure 2-6, click **OK** and select another (*.mp2) file.

After you have selected an acceptable video elementary stream file, all of the information about the file loads automatically into the Video Stream dialog box, as shown in Figure 2-7.

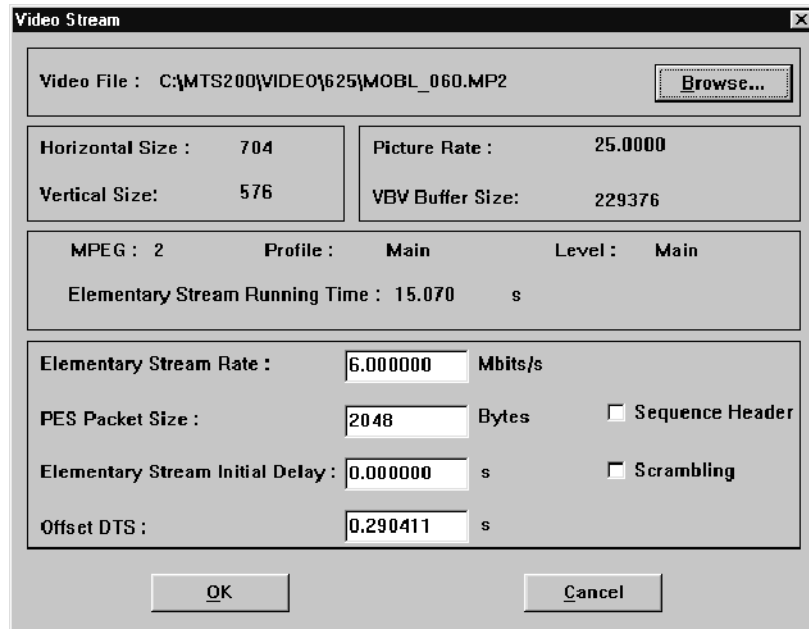

Figure 2-7: Details of the selected video elementary stream

You can change the following four parameters in the Video Stream dialog box (use the default values for this tutorial):

- Elementary Stream Rate
- PES Packet Size
- Elementary Stream Initial Delay
- Offset DTS

For more information about editing these parameters, refer to *Selecting a Video Stream*, beginning on page 3-47.

5. Click **OK** to accept these settings and close the dialog box. The lower portion of the multiplexer application window now resembles Figure 2-8. The file *MOBL_060.MP2* is associated with the video icon and the multiplex rate gauge is beginning to fill.

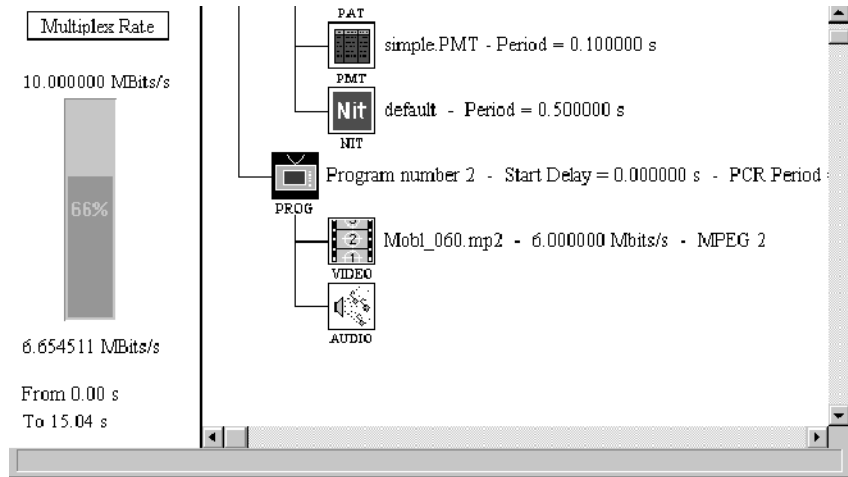

Figure 2- 8: Video icon and video elementary stream file

The fact that the rate gauge fill color is green indicates that you would not likely have multiplexer overflow problems if you were to create a transport stream file from the current configuration file.

Associate an audio elementary stream file with the Audio icon.

1. Double-click the Audio icon. This opens the Audio Stream dialog box shown in Figure 2-9.

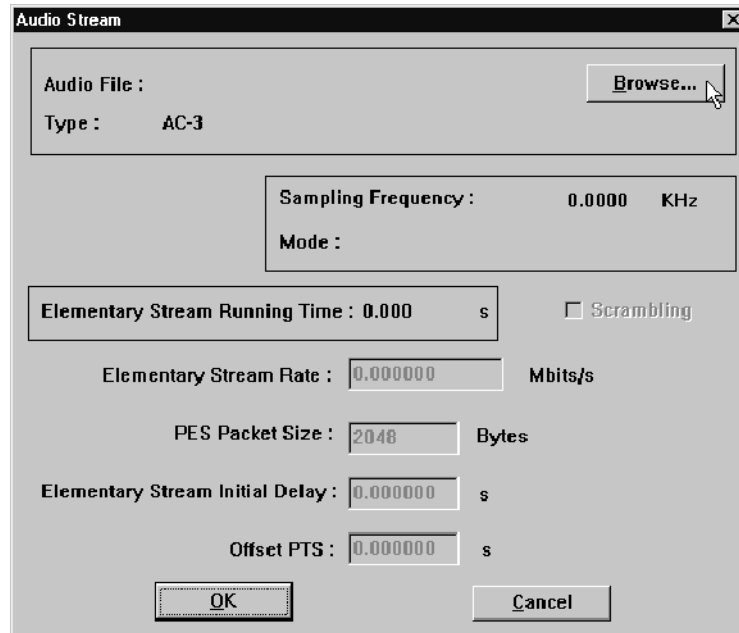

Figure 2-9: The Audio Stream dialog box

2. Click the **Browse** button to open the Audio Stream Selection dialog box.

3. Select **C:\MTS300\AUDIO\10KHZ.MP2** and click **OK**. This returns you to the Audio Stream dialog box with all the information about the 10KHZ.MP2 file entered, as shown in Figure 2-10.

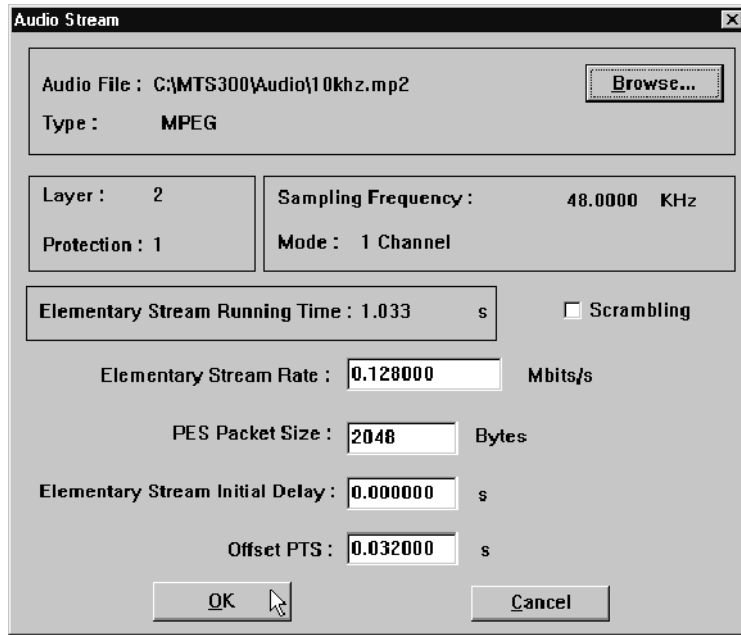

Figure 2- 10: Details of the selected audio elementary stream

You can change the following four parameters in the Audio Stream dialog box (use the default values for this tutorial):

- Elementary Stream Rate
- PES Packet Size
- Elementary Stream Initial Delay
- Offset PTS

For more information about editing these parameters, see *Selecting an Audio Stream*, on page 3-49.

4. Click **OK** to accept these settings and close the dialog box. This returns you to the hierarchic display of the configuration file as shown in Figure 2-11.

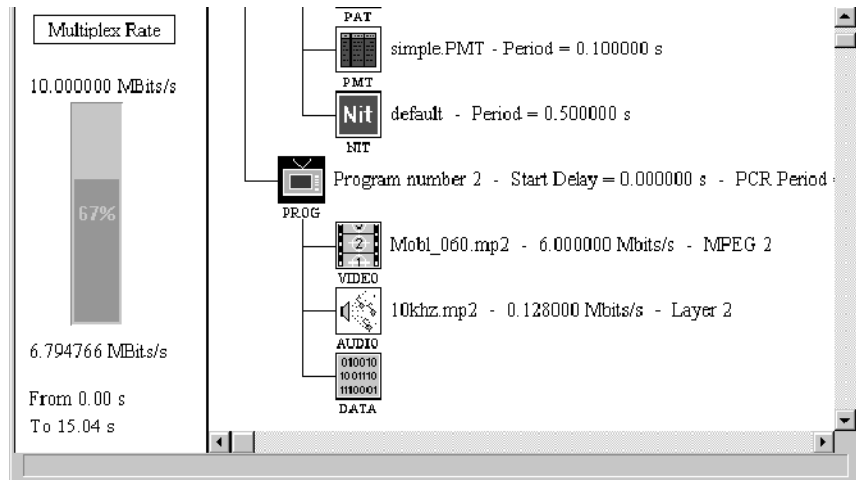

Figure 2-11: The display after an audio file is associated

The file *10khz.mp2* is now associated with the audio icon and the Multiplexer Rate gauge is a little closer to full.

Display the Data Stream dialog box; delete the Data icon from the hierarchy.

1. Double-click on the **Data** icon to open the Data Stream dialog box shown in Figure 2-12.

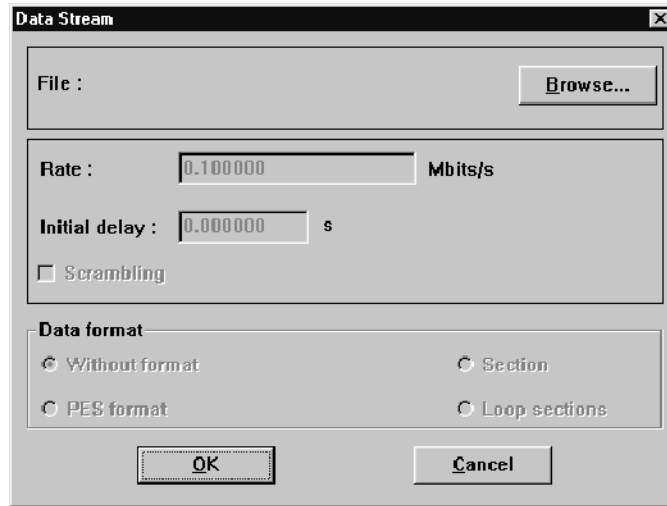

Figure 2-12: The Data Stream dialog box

This dialog box does not show as much information as the Video Stream or Audio Stream dialog boxes because it is for private-data elementary streams; a file of any type is acceptable.

Rather than add a data elementary stream file to the multiplex, delete the data icon from the Hierarchic view.

2. Click **Cancel** to close this dialog box without entering a file.
3. Select the **Data** icon.
4. Click the – (Delete) button on the toolbar (or select **Delete** from the Edit menu), and then click **Yes** when the message box appears. The Hierarchic view should now resemble Figure 2-13.

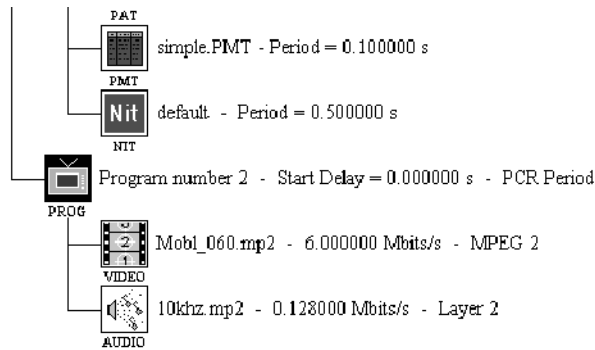

Figure 2- 13: The hierarchy with the Data icon deleted

5. Choose **Save** from the File menu to save the configuration file.

Create the Transport Stream File

In this section, you will create a transport stream file using the information from the configuration file and the PSI tables referenced by the configuration file.

1. Select **Go** from the Multiplex menu (or click the **Go** button on the toolbar).
2. Using the Multiplex Output File dialog box, specify the location and file name into which you will save your transport stream file.

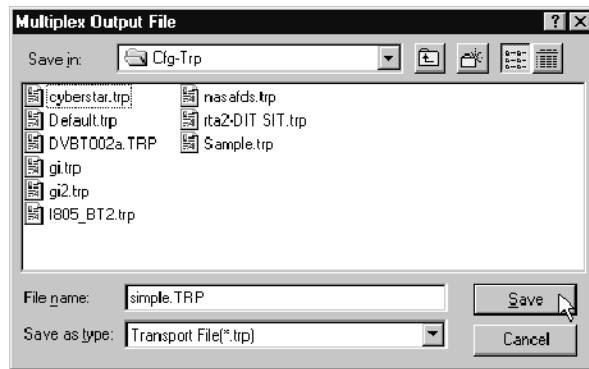

Notice that the current configuration file name becomes the default transport stream file name (with the file name extension changed to *.TRP).

NOTE. Transport stream files can be large. Make sure you have adequate space on the selected drive before beginning.

3. Choose **OK** to begin creating the simple.trp transport stream file in the default directory (C:\MTS300\cfg-trp).

As the multiplexer generates the transport stream file, the duration gauge at the top of the display fills, showing the status of the operation. When the transport stream file has been generated, the gauge reads 100% and a message box appears to indicate that the transport stream has been multiplexed.

4. Click **OK** close the message window. You have successfully created a simple transport stream file, and the multiplexer resembles Figure 2-14.

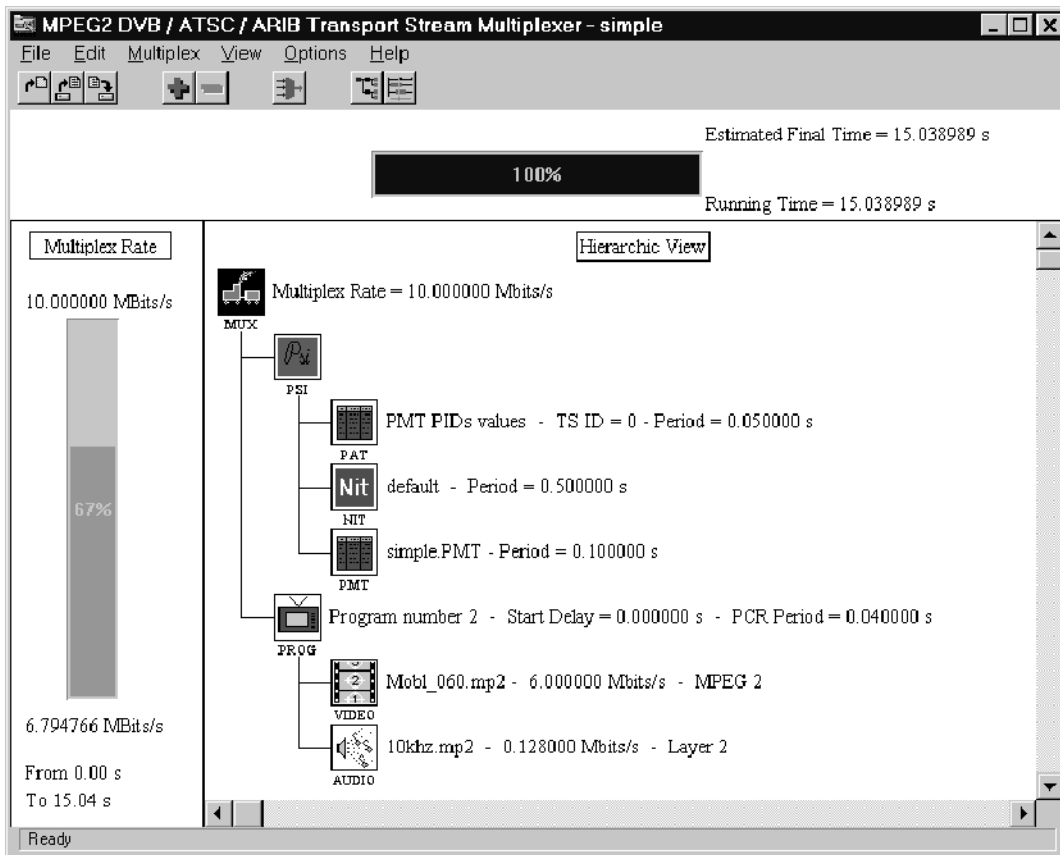

Figure 2- 14: Transport stream creation is complete

Creating a Complex Transport Stream File

To create a more complicated configuration file, add to the simple.cfg file you created in the previous tutorial.

Create a Complex Configuration File

1. Continuing from page 2-19, choose **Save As** from the File menu. The standard Windows Save As dialog box appears.
2. Use standard Windows techniques to save the file as *complex.cfg*.

Saving the information to a new configuration file creates a new .pmt file (called *complex.pmt*), and places the name “complex” in the title bar. The Duration gauge also resets itself to 0%.

Add More Programs

Add two additional programs to complex.cfg.

1. Select the **MUX** icon.
2. Click **+** on the toolbar, or select **Add** from the Edit menu. This creates Program 2.
3. Click **+** on the toolbar a second time to create Program 3. Figure 2-15 shows the resulting hierarchy.

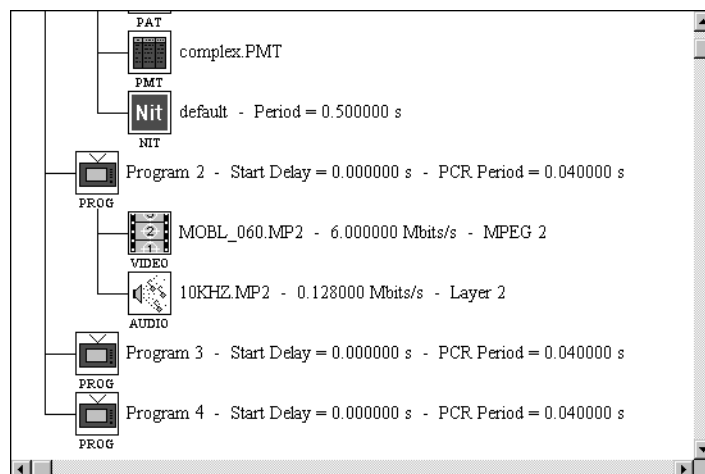

Figure 2- 15: The hierarchy with Programs 2 and 3 added

NOTE. The configuration file can accept up to 40 programs.

4. Follow the procedures on pages 2-10 to 2-19 to associate the following files to the video and audio icons for Program 3:
 - C:\MTS300\625\testpat\BARS_015.MP2 (video elementary stream)
 - C:\MTS300\audio\10KHZ.MP2 (audio elementary stream)

NOTE. Each program can accept up to 40 elementary streams, with a maximum of five video elementary streams and ten elementary streams of any one type.

The lower portion of the resulting application window looks like Figure 2-16. The Multiplex Rate gauge is yellow after adding the video and audio streams to Program 3. This indicates the transport stream is beginning to get full. If you were to multiplex a transport stream file from the configuration file when the rate gauge is yellow, you may experience multiplexer overflow problems.

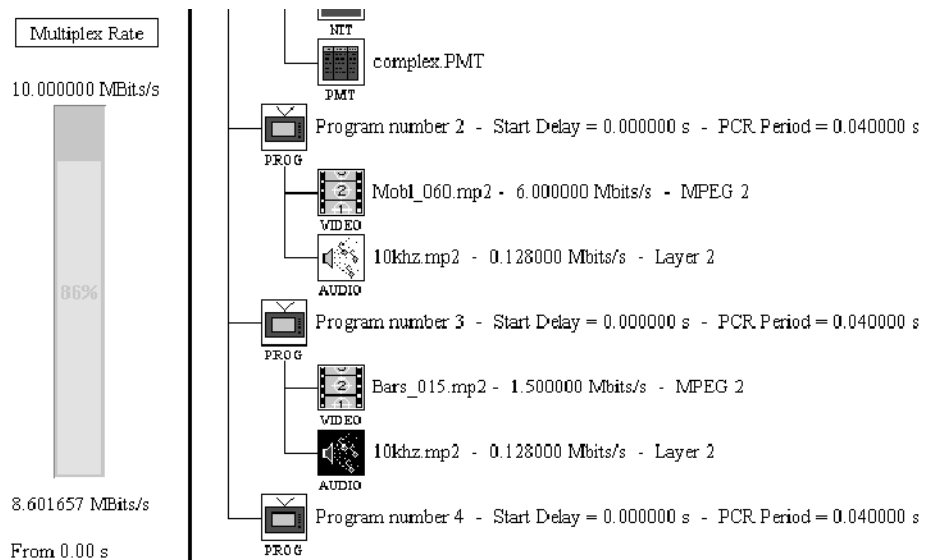

Figure 2-16: Elementary streams added to Program 3

- Repeat step 4 and add the same video and audio elementary stream files to Program 4. The lower portion of the application window now resembles Figure 2-17.

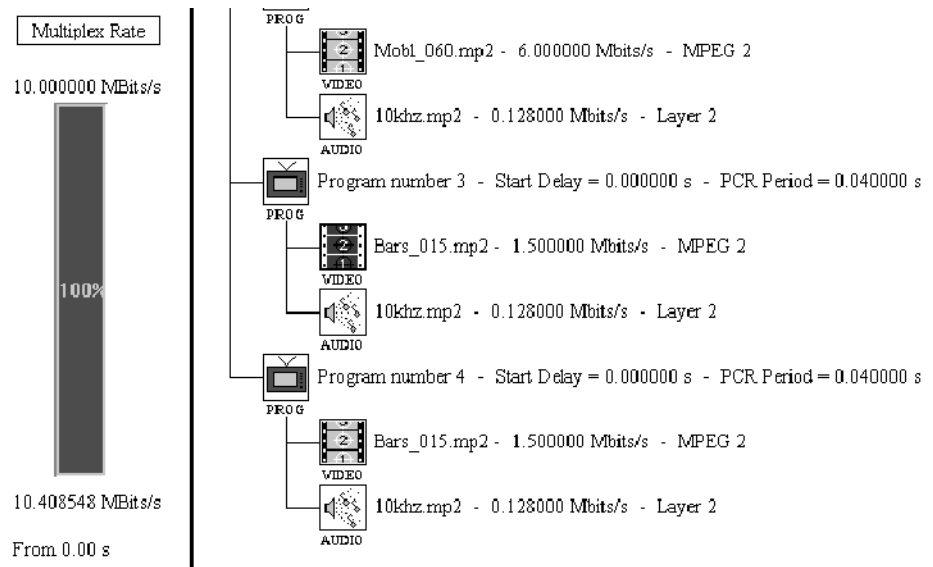

Figure 2-17: The rate gauge shows an overflowed multiplex

The rate gauge reads 100% and is now displayed in red. The rate reported at the bottom of the gauge is greater than the specified maximum rate at the top. If you multiplex the stream now, you risk losing data. To avoid losing data you need to change the start delay for one or more of the programs in the multiplex.

Change Program Starting Time

Change the start times for Program 2 and Program 3 so that the multiplex rate drops to an acceptable level.

1. Change the view from hierarchic to dynamic; choose **Dynamic** from the View menu or click Dynamic on the toolbar.

The display now resembles Figure 2-18. This view shows the timing relationships between programs. For more information about this view, see *The Dynamic View* on page 3-16.

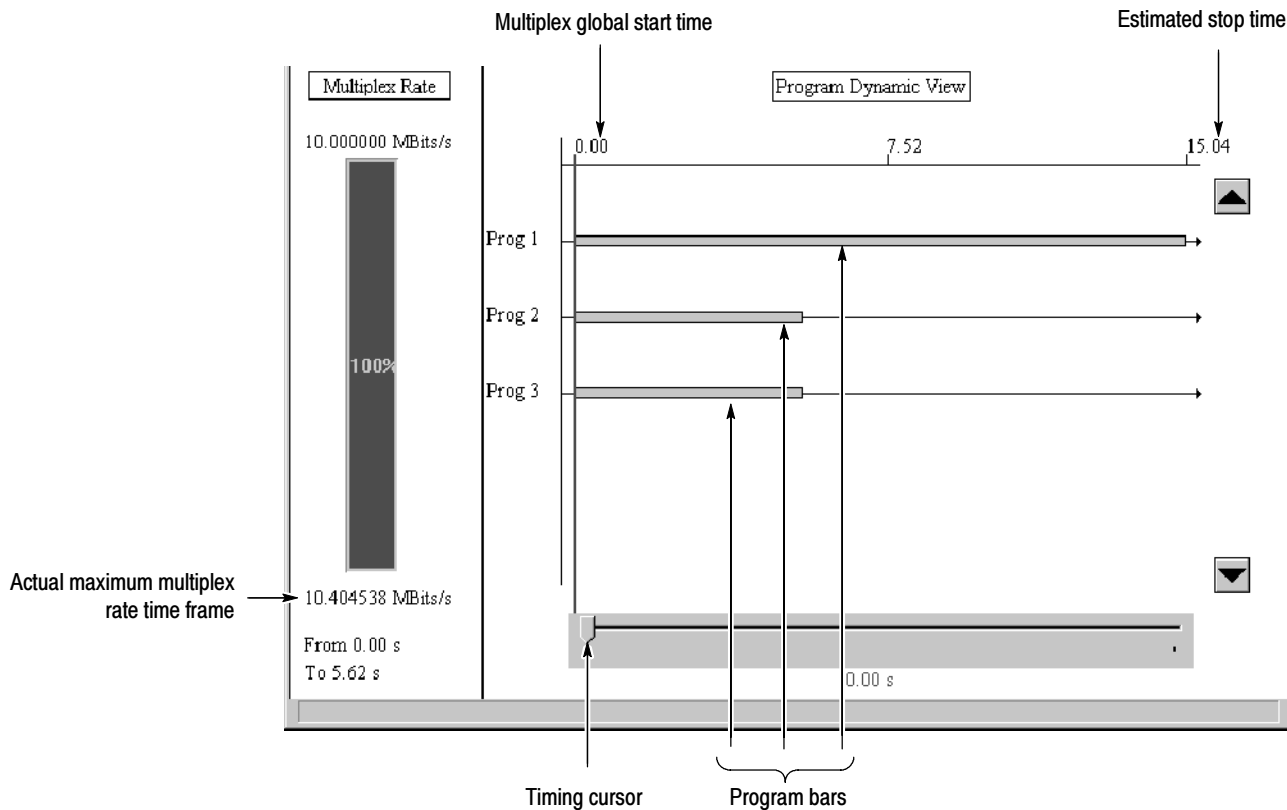

Figure 2- 18: The dynamic view of the complex.cfg configuration file

Notice that the time frame for the actual multiplex rate, shown at the bottom of the multiplex rate gauge, is from 0.00 s to 15.07 s. In order to decrease the actual bit rate when you multiplex the configuration file to safe parameters, you need to delay the start time for Program 2 and Program 3 so that both start after Program 1 ends.

NOTE. In the Dynamic view, the program number refers to the order of programs in the configuration file, so Program 1 is the first program in the file. The PMT program_number parameter value for this program will be 2 in the multiplexer Hierarchic view. In order to avoid conflicts with the ATSC program paradigm and the DVB requirement for a NIT (PID = 16), the multiplexer does not use program_number 1.

You modify the start times for individual programs through the Program icon in the Hierarchic view. Referring to Figure 2-18, note the estimated stop time for Program 1 (roughly 15.0 seconds).

2. Return to the Hierarchic view by clicking the **Hierarchic** button on the toolbar.
3. Double-click the **PROG** (Program) icon for Program 3. This opens the Program Parameters dialog box shown in Figure 2-19.

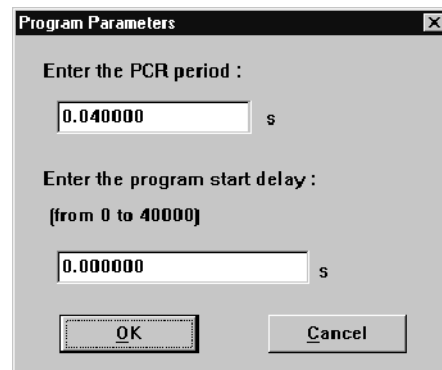

Figure 2-19: The Program Parameters dialog box for Program 2

4. Enter 15.2 in the Enter the Program Start Delay text box.
5. Click **OK**. The rate gauge drops and turns yellow.
6. Repeat steps 4 and 5 for Program 4, setting the Program Start Delay to 20.5. The rate gauge now shows 67% and is again green.
7. Switch to the Dynamic view to see the new timing relationships between programs (see Figure 2-20). Programs 2 and 3 do not begin until Program 1 ends, and the resulting transport stream now takes longer (note the Estimated Stop Time).

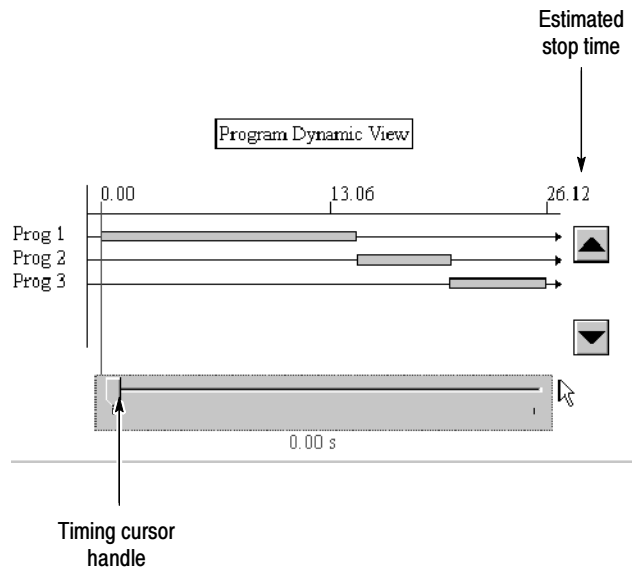

Figure 2-20: The dynamic view after you delay Programs 3 and 4

8. You can move the timing cursor by clicking and dragging the timing cursor handle at the bottom of the Program Dynamic View window. Click and drag the timing cursor to the right and left. Once the timing cursor is selected, you can also move it 0.01 second at a time with the the left and right arrow keys.
9. Move the timing cursor into the area that contains only the second and third programs; the Multiplex Rate drops even lower.
10. For practice, see if you can move the timing cursor to the space between the end of the first program and the start of the second. Use the left and right arrow keys for fine cursor movement.
11. Return to the Hierarchic view.

Customize Program Specific Information (PSI)

You can customize PSI for the transport stream file by double-clicking the PSI table icons.

PSI. The PSI icon accesses the PSI period values for three PSI tables.

1. Double-click on the **PSI** Icon. This opens the PSI Period dialog box. See Figure 2-21.

The PSI Period dialog box allows you to change how often the following program specific information (PSI) appears in the stream.

- PMT (Program Map Table)
- PAT (Program Allocation Table)
- CAT (Conditional Access Table)
- TSDT (Transport Stream Descriptor Table)

NOTE. If you have the conditional access option installed on your system, the CAT period is accessible in the PSI Period dialog box, regardless of whether you have enabled a scrambling option. See Using Option CA: Scrambling / Conditional Access beginning on page 3-89 for more information about the CAT. Modifying the CAT period has no effect unless a scrambling option is enabled.

The NIT period is set separately. See Editing the NIT, beginning on page 3-42.

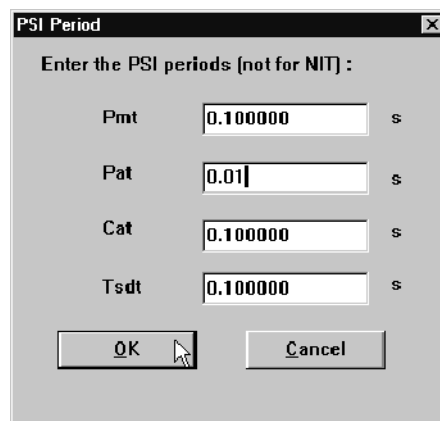

Figure 2-21: The PSI period is changed to 0.01 seconds

In this example, you want to send the PSI more often than the default, so you must decrease the period for one or more of the tables.

2. Enter **0.01** in the PMT and PAT text boxes as shown in Figure 2-21, and then click **OK**. (Clicking **Cancel** will close the dialog box without making any changes to the periods to the PSI tables.)

Notice the changes to the Hierarchic view and the multiplex rate. First, the new period is displayed after the PAT and PMT icons in the hierarchy; second, decreasing the period for the PAT and PMT (increasing the rate) used an additional 3% of the available multiplex space as shown in the rate gauge. See Figure 2-22.

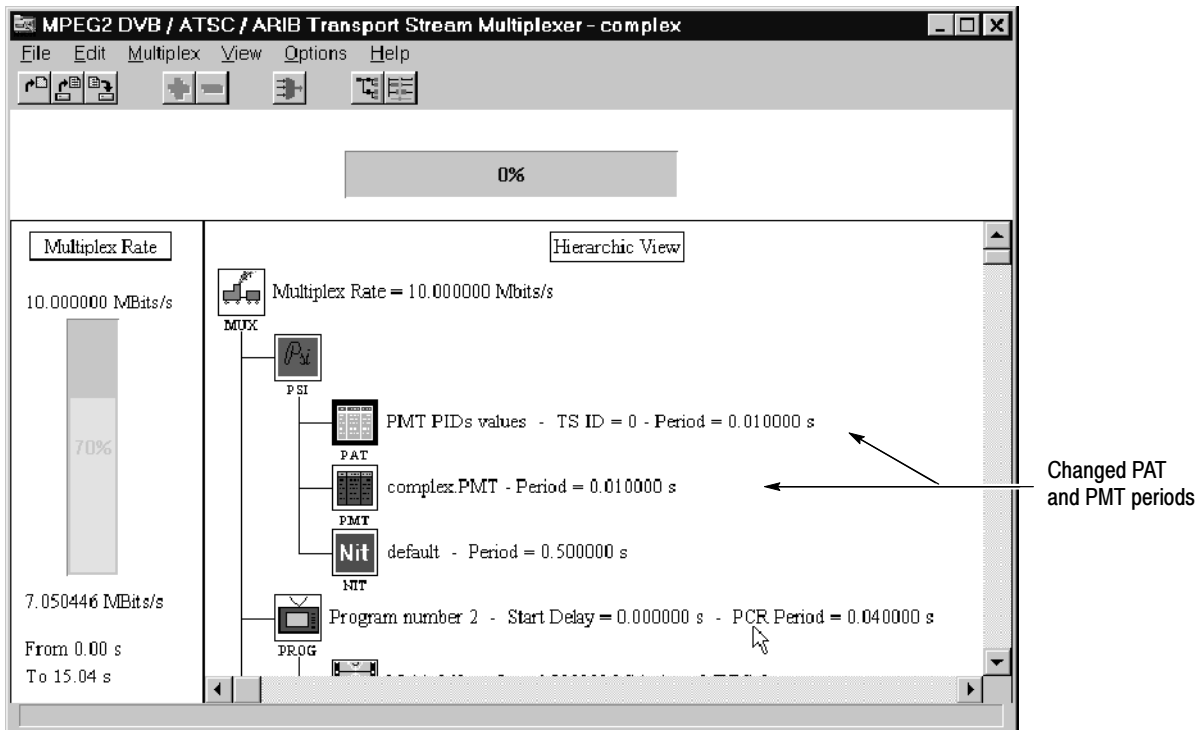

Figure 2-22: The configuration file after changing the PSI period

PAT. The PAT (Program Association Table) lists the Transport Stream ID and the PIDs for the PSI tables. In this case, it includes the NIT and three PMTs (one for each program).

1. Double-click on the **PAT** icon. This opens the Program Association Table dialog box as shown in Figure 2-23.

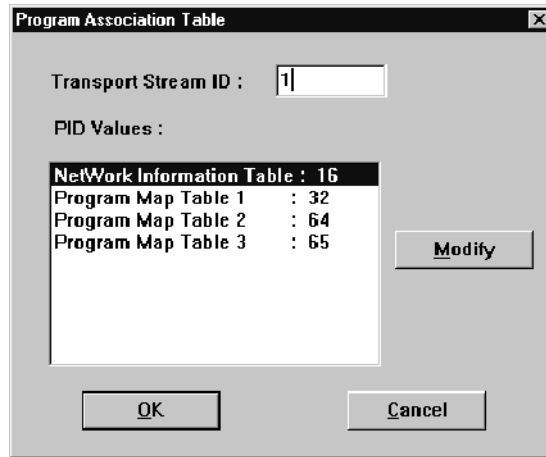

Figure 2-23: The Program Specific Information dialog box

2. Select **NetWork Information Table**.
3. Click **Modify** to open the PID Modification dialog box as shown in Figure 2-24.



Figure 2-24: PID Modification dialog box

This dialog box allows you to change the Program ID of the selected table (in this case the Network Information Table). To change the PID, enter a new number in the text box. Usually you do not need to change the PID of the NIT or PMTs since the multiplexer allocates these values dynamically and as required for the selected environment (MPEG-2, DVB, or ATSC).

4. Cancel the PID Modification dialog box.

5. Cancel the Program Association Table dialog box.

PMT. The PMT (Program Map Table) contains specific information about the programs in the transport stream file.

1. Double-click on the **PMT** icon. This automatically starts the DVB Table Editor application with complex.pmt (the PMT for the complex.cfg configuration file) loaded, as shown in Figure 2-25.

The two views displayed in the table editor are described below:

- The Hierarchic view displays icons representing the table and table elements.
- The Edit view displays the parameters and values for the table elements

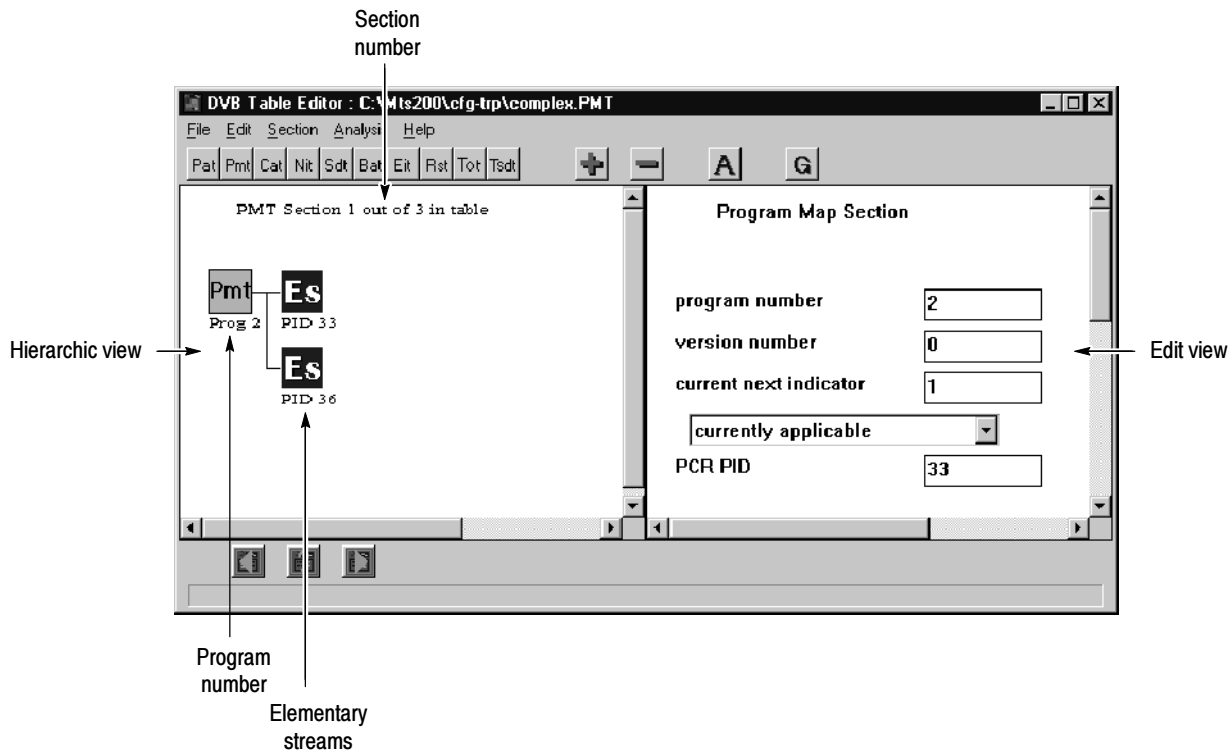

Figure 2-25: The DVB Table Editor with complex.pmt loaded

Note the following before continuing:

- There is one section for each program and the current file has three programs.
- Section 1 of 3 is currently being displayed.

- There are two elementary ES streams (one video and one audio) associated with this program.

For more information about using the DVB Table Editor application, refer to *Using the DVB and PSIP Table Editors*, beginning on page 3-93.

NOTE. You can change the PCR PID (in the last text box of the right hand window). The default is the first elementary stream in the program. If you change it to a different value, and that value is not the PID of another elementary stream in the program, PCRs will then reside in their own transport packets. Use this technique if the elementary stream that would carry the PCR by default is not the longest elementary stream in the program.

2. Add some descriptors to Section 2 of PMT (Program 2). To display Section 2, chose **Next** from the Section menu or click ► in the lower toolbar. See Figure 2-26.

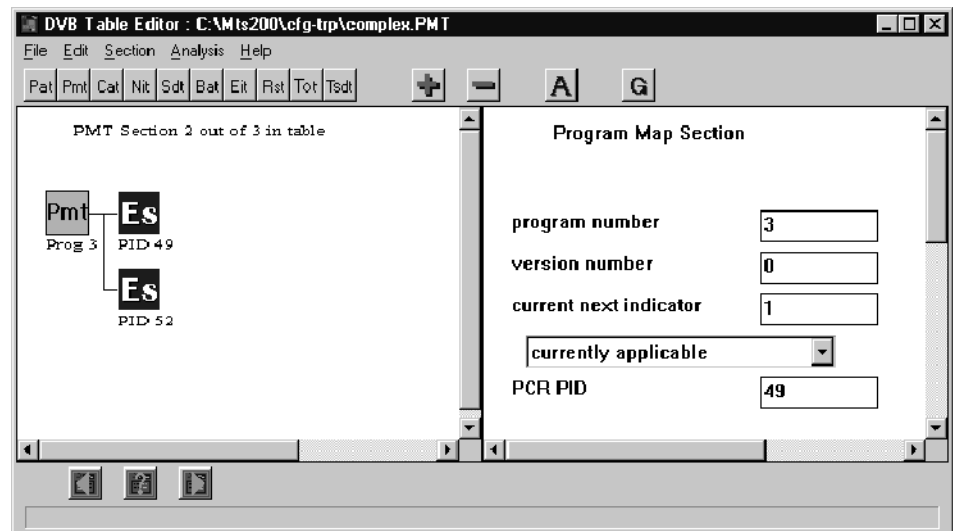

Figure 2-26: Section 2 (Program 3) of the PMT

3. Select the **PMT** icon.
4. Choose either **Add** from the Edit menu or "+" from the toolbar. This opens the Descriptors Selection dialog box. See Figure 2-27.

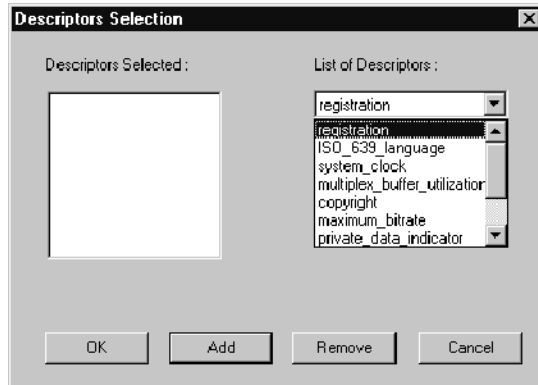

Figure 2-27: The Descriptors Selection dialog box

5. Click on the **List of Descriptors** drop-down list to display the available descriptors.
6. Add a registration descriptor
 - a. Select **registration** from the drop-down list.
 - b. Choose **Add**. This adds the descriptor to the Descriptors Selected list. The dialog box now resembles Figure 2-28.

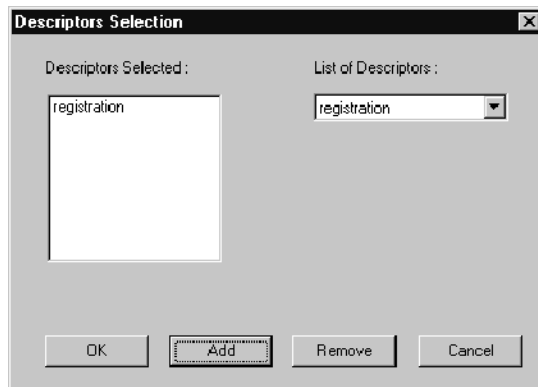

Figure 2-28: Registration selected

7. Click **OK** to add the descriptor. (See Figure 2-29.)

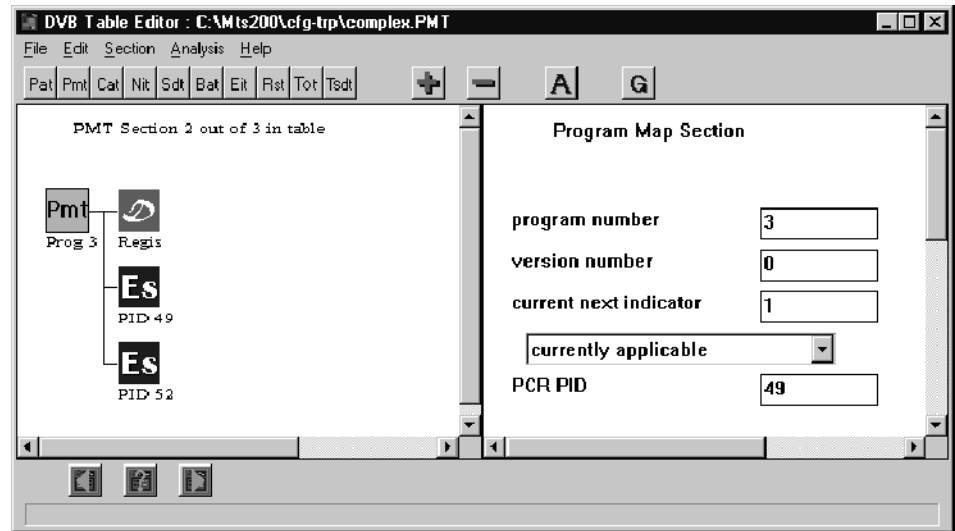

Figure 2-29: A registration descriptor added to PMT section 2

8. To check the information added in the descriptor, click on the descriptor icon (see Figure 2-30). Do not change any of the information.

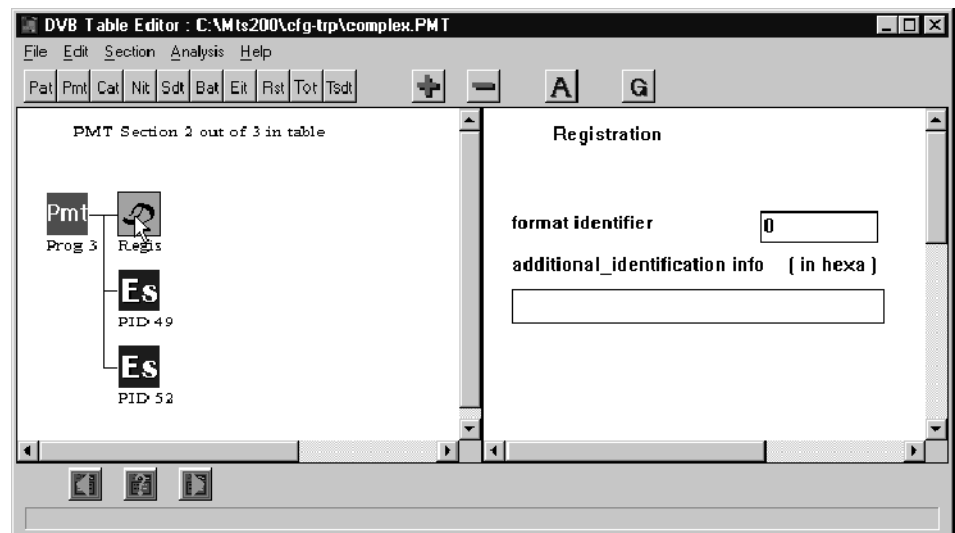

Figure 2-30: The information for the Video Stream descriptor field

9. To add a video stream descriptor to the video elementary stream, select the **PID 49** elementary stream icon.
10. Choose **Add** from the toolbar.

11. Select **video_stream** from the List of Descriptors.
12. Click the **Add** command button to add it to the Descriptors Selected list.
13. Choose **OK**.
14. Click on the resulting descriptor icon to open the display shown in Figure 2-31.

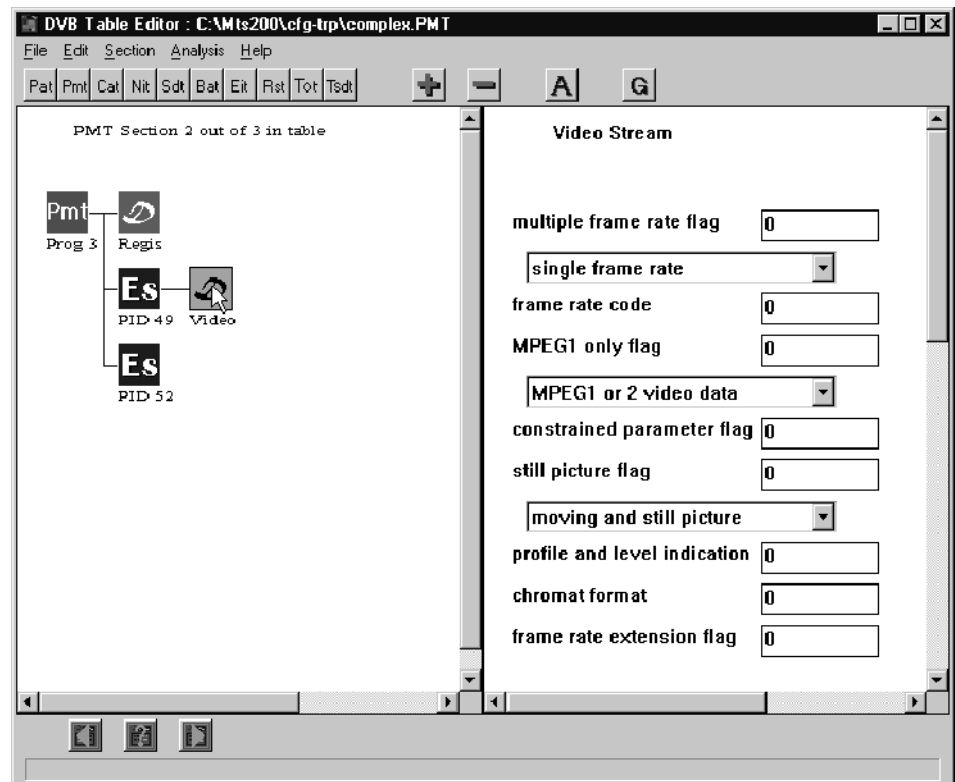

Figure 2-31: The descriptor at the Elementary Stream level

15. Choose **Save** from the File menu.
16. Exit the table editor and return to the Multiplexer application.

You can find additional information on customizing the PSI for your transport stream in *Using the DVB ,PSIP, and ARIB Table Editors* (beginning on page 3-93) and *Using the Multiplexer* (beginning on page 3-3), in the *Reference* section of this manual.

Multiplex the Transport Stream File

1. Choose **Go** from the Multiplex menu. This opens the Multiplex Output File dialog box.
2. Enter the path and file name into which you will save the transport stream file.
3. Choose **OK** to begin the multiplex process.

When the multiplex is complete, the duration gauge reads 100% and the message shown in Figure 2-32 appears.

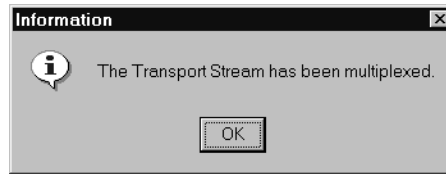

Figure 2-32: Multiplex complete message

4. Click **OK**, and then exit the Multiplexer application.

Generate a Transport Stream

In this section of the tutorial you need to have the transport stream file located on the Tektronix MTS300 MPEG Test System with the Master Client and Stream Player applications.

Starting the Master and Stream Player Clients

1. Start the Master client.
 - a. Double click the Master Client icon in the MPEG Test System program group window.
 - b. Click the **Connect locally** button on the toolbar. See Figure 2-33.

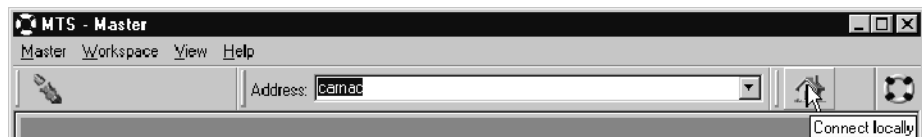

Figure 2-33: Connect locally button

The Master Client display changes showing that you are connect to a Server Manager (in this case the local Server Manager). See Figure 2-34 on page 2-36.

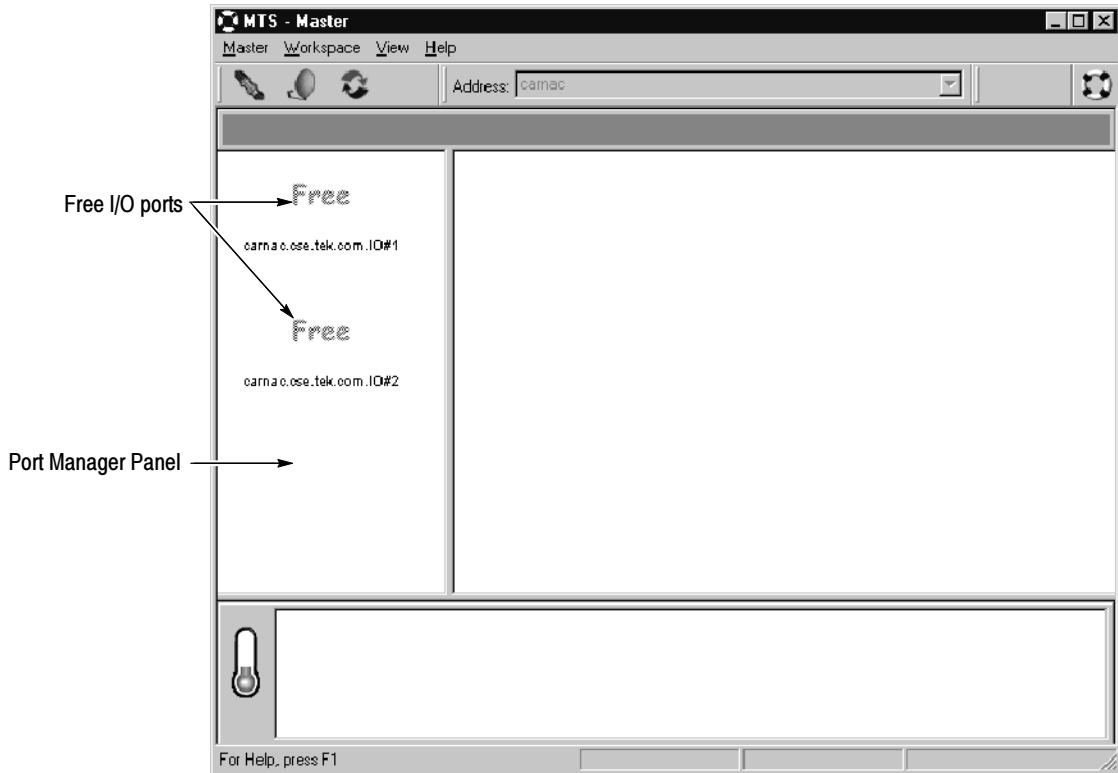

Figure 2-34: Master Client application window

2. In the Master Client Port Manager panel, right click the port from which you will output the transport stream, point to Assign Server in the popup menu, and then select Stream Player from the submenu as shown Figure 2-35.

In this illustration, the Stream Player Server is being assigned to I/O port two.

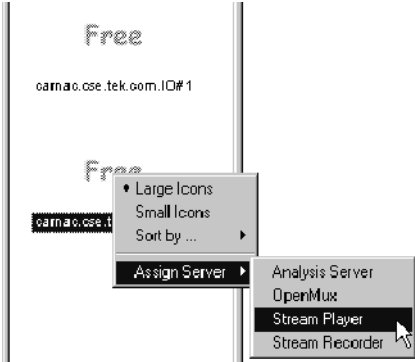

Figure 2-35: Assigning the Stream Player Server to I/O port two

- 3. Right click the icon that appears at the port you selected, and then select **Launch Stream Player Client**. The Stream Player application is displayed.



Figure 2-36: Stream Player Client application window

Output the Transport Stream

Now you can generate a transport stream from the transport stream file.

1. Click the Browse button, and then navigate to and select **Complex.trp**. When you return to the Stream Player application the file you have selected is shown in the File Name text box as shown in Figure 2-37.



Figure 2-37: Select Complex.trp from the File information list

2. Click the **Start Generation in Loop Mode** button, accepting the default settings.

This completes the basic tutorial on generating a transport stream. If you need additional information, please see the *Using the Multiplexer* and *Using the DVB and PSIP Table Editors* in the *Reference* section of this manual.

For more information about the Stream Player, Master Client, and Analysis Servers, and for information about analyzing the stream you are generating, see the *MTS300 MPEG Test System Real-Time Analysis User Manual*.

For more information about the Stream Player, see the *MTS 300 Series Real-Time Analysis User Manual*.

Creating a Transport Stream File with DVB Information

The multiplexer can generate transport stream files for MPEG-2, DVB, ATSC, and ISDB-S/ARIB broadcast environments. In this tutorial, you will create a transport stream file for the DVB environment.

In addition to introducing you to the capabilities of the multiplexer, this tutorial will also help you become more familiar with the capabilities of the table editors. You use only the MTS300 DVB Table Editor for this tutorial, but the basic procedures are similar for the MTS300 PSIP Table Editor.

For more detailed information about using the table editors see *Using the DVB and PSIP Table Editors* beginning on page 3-93. For detailed descriptions of specific table item parameters, see *PSI, DVB SI, and ATSC PSIP Table Item Parameters* beginning on page 3-143.

Create a DVB Configuration File

This section is a continuation from the previous tutorial. It assumes that you have completed the previous work and have the resulting files.

1. If not already open, start the multiplexer by double-clicking the Multiplexer icon in the Tektronix MPEG Test System program group window.
2. Select **Open** from the multiplexer File menu.
3. Select **complex.CFG**.
4. Click **OK**. This opens the previous configuration file and displays it in the application window.
5. Select **Save As** from the File menu.
6. Type **dvb** in the File Name text box, and then click **OK**.

Change the Multiplexer Environment

To create a configuration file with DVB information, you must set the multiplexer environment for DVB.

- To change the multiplexer environment, select **DVB** from the Options menu.

The SI (Service Information) icon is added to the Hierarchic view and the NIT (Network Information Table) icon appears below the SI icon, as shown in the following illustration.

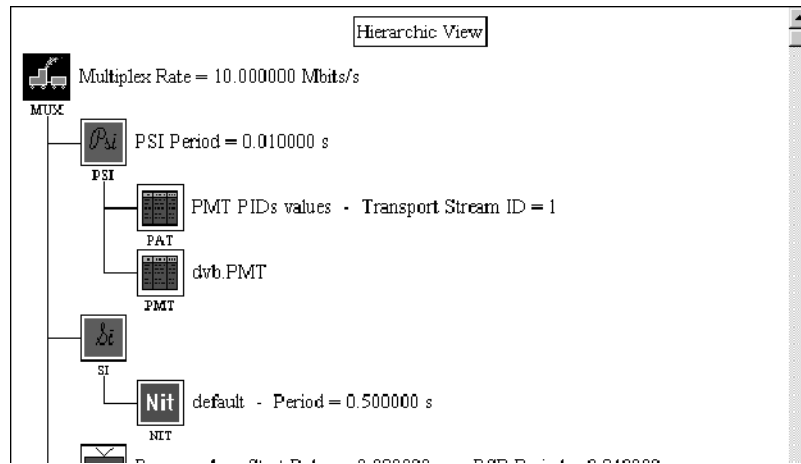

Add DVB SI Tables

To create a valid DVB transport stream file, you must add more DVB table icons to the configuration file. When you installed the stream creation applications, a number of default DVB table files were installed in the C:\MTS300\CFG-TRP directory. You will use these files as templates for the tables files needed for the configuration file.

1. Double-click on the **SI** icon to open the DVB File Selection dialog box.

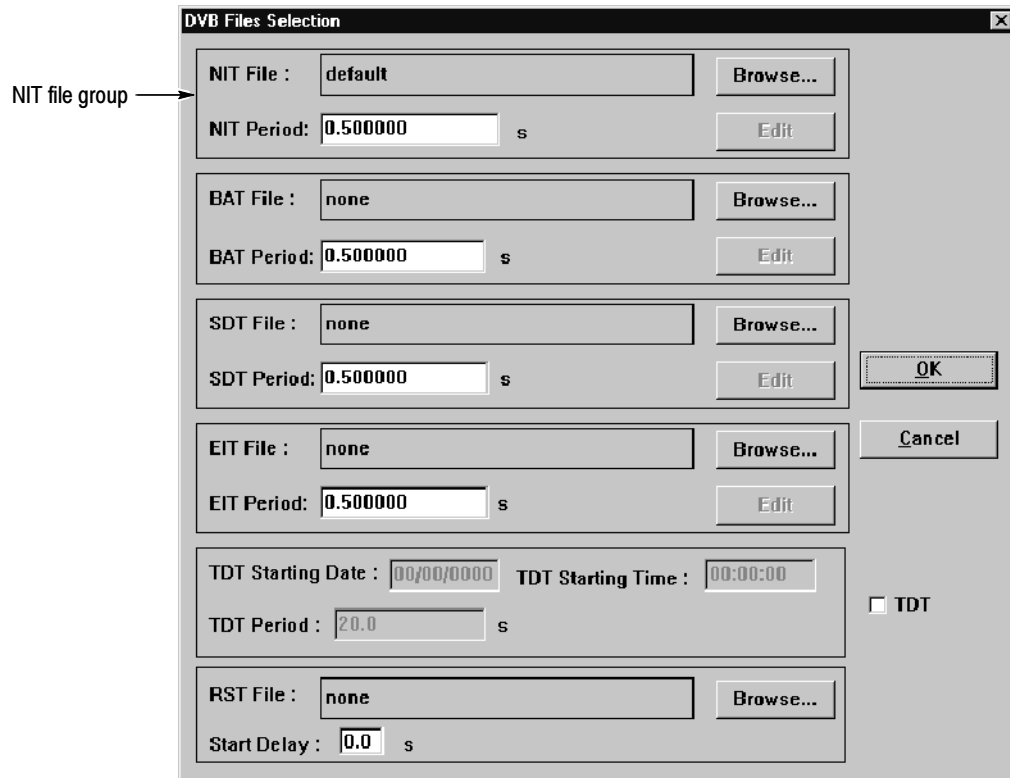

2. Click **Browse** in the NIT file group of the DVB Files Selection window. The Selection SI File dialog box is displayed.
3. Navigate to the C:\MTS300\CFG-TRP directory.

NOTE. All table template files are located in the C:\MTS300\CFG-TRP directory.

4. Select **Default.NIT** in the Selection SI File dialog box, and then click **OK**.
5. Click **Browse** in the BAT File section of the DVB Files Selection window.
6. Select **Default.BAT** in the Selection SI File dialog box, and then click **OK**.
7. Click **Browse** in the SDT File section of the DVB Files Selection window.
8. Select **Default.SDT** in the Selection SI File dialog box, and then click **OK**.

9. Click **Yes** in the warning message box if displayed. You will correct the Transport Stream ID error in a later step of this tutorial.

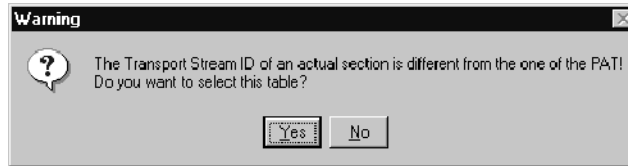

10. Click **Browse** in the EIT File section of the DVB Files Selection window.
11. Select **Default.EIT** in the Selection SI File dialog box, and then click **OK**.
12. Click **Yes** in the warning message box if displayed. You will correct the Transport Stream ID error in a later step of this tutorial.
13. Click **OK** in the DVB Files Selection dialog box. The Hierarchic view now includes icons for the tables you added, as shown in the following illustration.

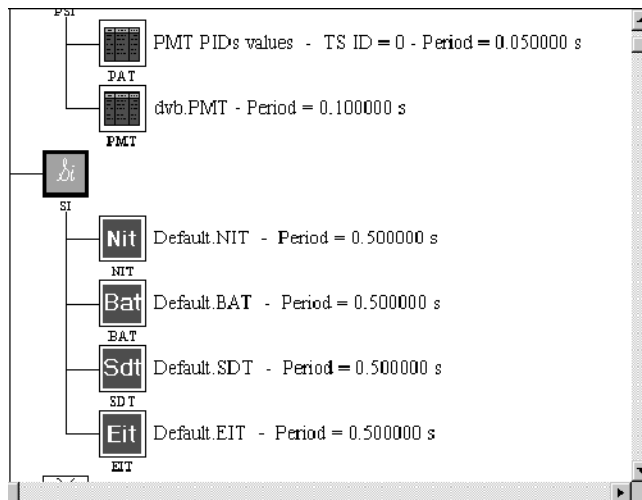

NOTE. You can also edit the TDT parameters using the DVB Files Selection dialog box. Initially the TDT text boxes are grayed out; in order to edit these parameters, click the TDT check box in the lower right of the display. However, you will edit these parameters using a different technique in this tutorial.

Edit the NIT

You can edit DVB table periods using the multiplexer. However, to create a coherent transport stream file, you also need to add some table descriptors and edit table parameters using the MTS300 DVB Table Editor. In this section, you will edit the NIT using the table editor.

1. Double-click on the **NIT** icon to open the NIT dialog box.

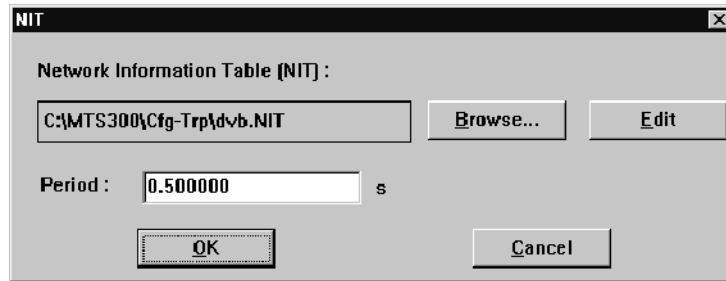

2. Click **Edit**. This starts the Table Editor application with Default.NIT file displayed.

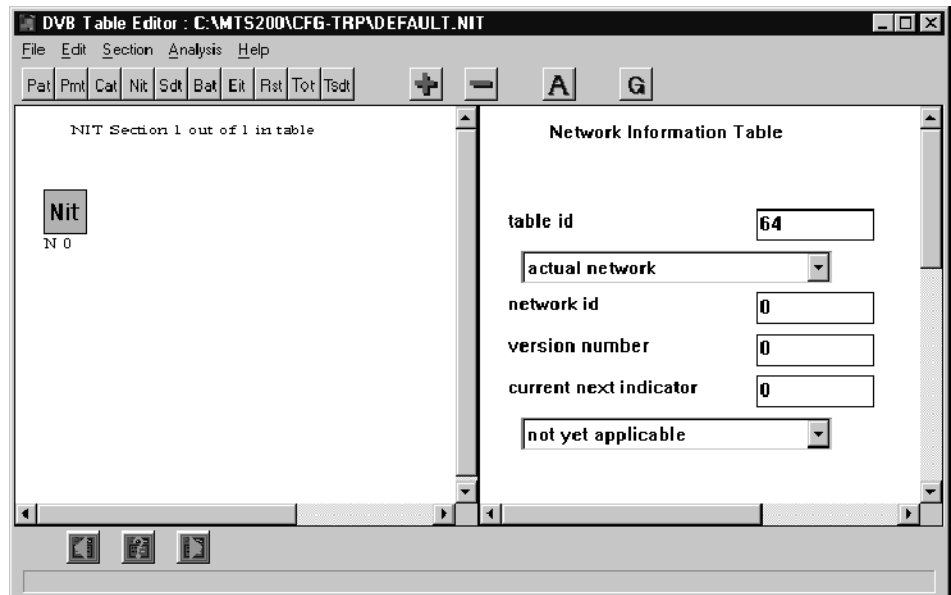

3. Select **Consistency** from the Analysis menu (or click the **A** command button on the toolbar). This runs a coherence analysis on the NIT. A message window appears listing the problems found in the table.

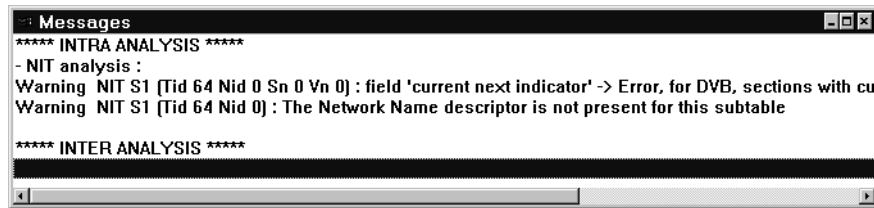

NOTE. Some table editor error messages include error codes at the end of the error message text (you may have to scroll the window to make it visible). You can use these error codes to locate descriptions of the messages, and possible solutions, in the table editor online help. See Interpreting Error Messages, beginning on page 3-130 for more information.

4. To resolve the *current next indicator* warning, select **currently applicable** from the current next indicator drop down list box.
5. Click **A** again on the toolbar. This runs another analysis on the NIT. The message window changes to list the remaining problem found in the table.
6. To resolve the *Network Name descriptor is not present for this subtable* warning, you must add the network_name descriptor to the NIT.
7. Choose **Add** from the Edit menu (or click the + command button). This displays the Add dialog box.

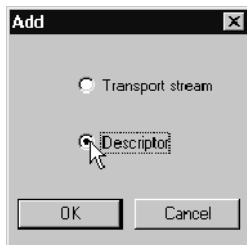

8. Select **Descriptor**, and then click **OK**. This displays the Descriptors Selection dialog box.

9. Select **network_name** from the List of Descriptors drop-down selection box.

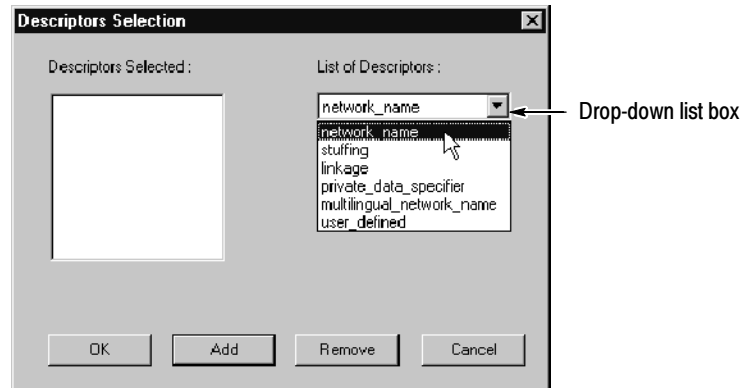

10. Click **Add** and *network_name* appears in the Descriptors Selected list.
11. Click **OK** to complete the descriptor selection and close the dialog box.
12. The descriptor icon is added to the right of the NIT icon in the Hierarchic view window.

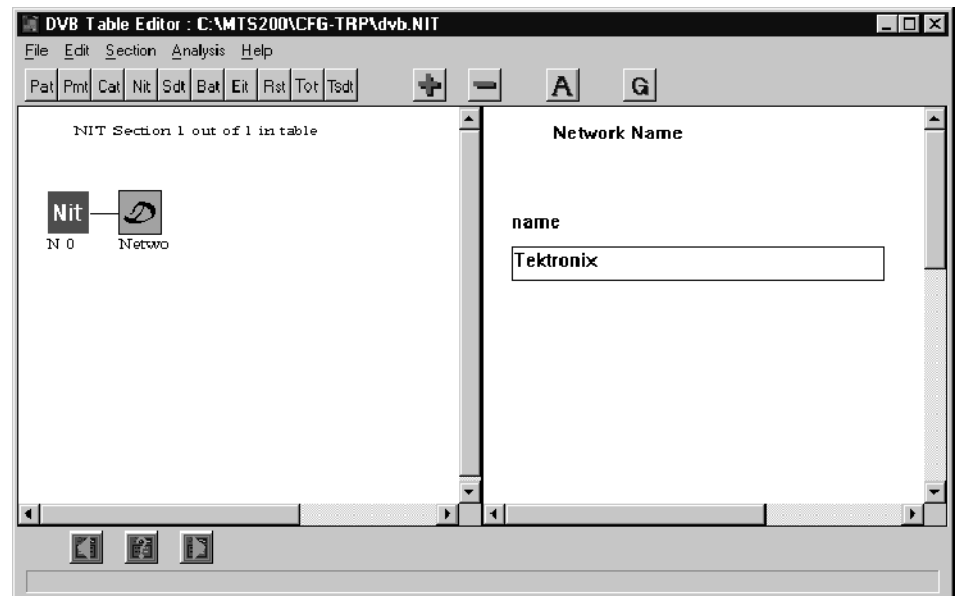

13. Click the **Netwo** (Network) descriptor icon, and type *Tektronix* in the name text box (to the right in the application window).

NOTE. *In the following step, do not choose the Save command. Doing so will change the Default.NIT file, which is provided as a template.*

14. Select **Save As** from the File menu.
15. Type **dvb** in the file name box and click **OK**. The **.NIT** file name extension is added automatically.
16. Select **Exit** from the File menu.
17. In the NIT dialog box, click **Browse**.
18. Select **dvb.NIT** from the Selection SI File dialog box, and then click **OK**.
19. Click **OK** in the NIT dialog box to confirm the file selection and dismiss the window. The NIT file associated with the **dvb.cfg** configuration file is now **dvb.NIT**.

Edit the BAT

In this section, you will edit the BAT using the table editor.

1. Double-click on the **BAT** icon to open the BAT dialog box.

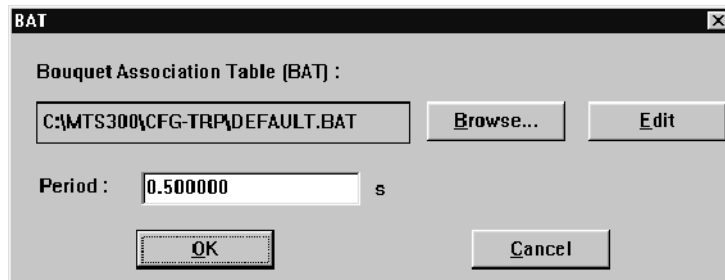

2. Click **Edit** in the BAT dialog box. This starts the DVB table editor with **Default.BAT** open for editing.

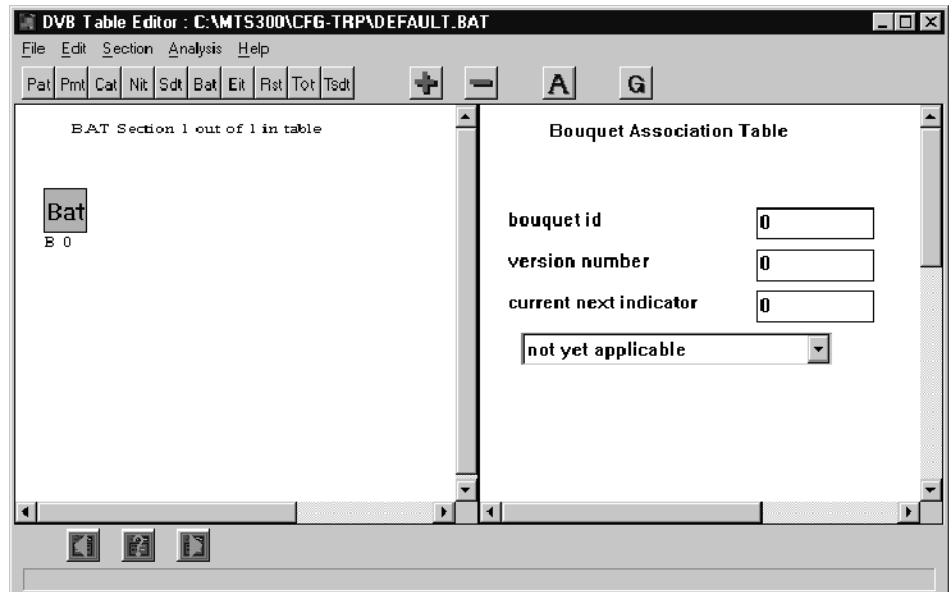

3. Click the **A** (Analyze) command button to perform an analysis of the BAT. A message window lists the problems found in the table.

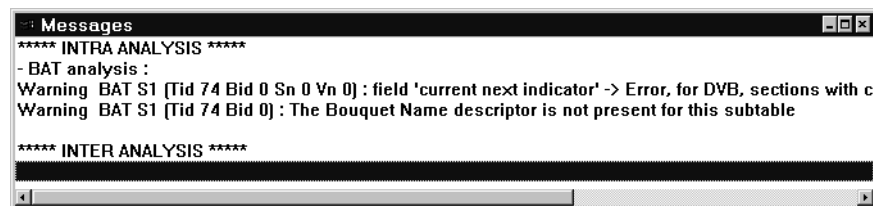

4. To resolve the *current next indicator* warning, select **currently applicable** from the current next indicator drop down list box.
5. To resolve the *Bouquet Name descriptor is not present for this sub-table* warning, click the **+** (Add) command button, and then select **Descriptor** from the Add dialog box. This displays the Descriptors Selection dialog box.
6. Select **bouquet_name** from the List of Descriptors drop-down selection box.
7. Click **Add**, and then click **OK** to complete the descriptor selection and close the dialog box.
8. Click the **Bouqu** (Bouquet) descriptor icon, and type a name for the bouquet in the Name text box (to the right in the application window).
9. Click the **A** (Analyze) command button. There should be no more warnings in the message window.

NOTE. *In the following step, do not choose the Save command. Doing so will change the Default.BAT file, which is provided as a template.*

10. Select **Save As** from the File menu.
11. Type `dvb` in the File Name text box and click **OK**. The table description is saved as `dvb.BAT`.
12. Select **Exit** from the File menu. This returns you to the BAT dialog box of the Multiplexer application.
13. In the BAT dialog box, click **Browse**.
14. Select **dvb.BAT** from the Selection SI File dialog box.
15. Click **OK** in the BAT dialog box to accept the selection of `dvb.BAT` and dismiss the box. This associates `dvb.BAT` with the BAT icon in the `dvb.cfg` configuration file.

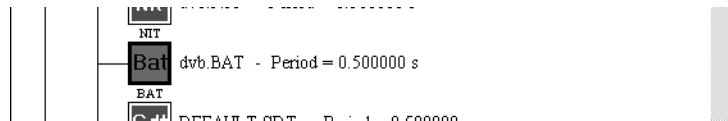

Edit the SDT

In this section, you will edit the SDT using the table editor.

1. Double-click on the **SDT** icon to display the SDT dialog box.
2. Click **Edit** in the SDT dialog box. This starts the Table Editor application with `Default.SDT` open for editing.
3. Perform an analysis of the SDT (select **Consistency** from the Analysis menu or click the **A** button in the toolbar).
4. Again, the warning states that the current next indicator field value is incorrect. Select **currently applicable** from the Service Description Table current next indicator drop-down list.
5. Save the SDT as `dvb.sdt`.

6. Exit the table editor. The error message that appeared when you first added Default.SDT to the hierarchy may reappear. Click **OK**.

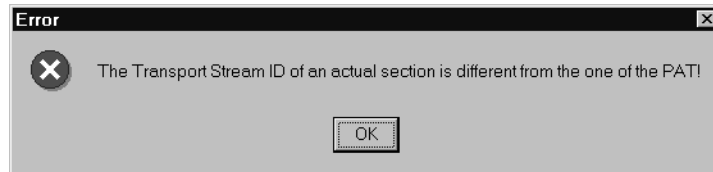

7. If you see the message shown above, identify the Transport Stream ID from the PAT icon in the Multiplexer hierarchy:
 - a. You must close the SDT dialog box before you can scroll to the PMT icon. Click **OK** in the SDT dialog box.
 - b. Scroll the multiplexer window until you can see the PMT icon. Note that the Transport Stream ID is 1.

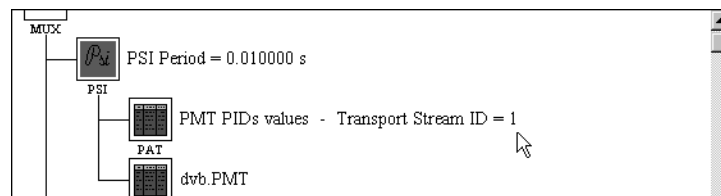

8. Open the dvb.sdt file in the table editor:
 - a. Scroll the **SDT** icon back into view and double-click on it.
 - b. Click **Browse** and select **dvb.SDT** from the Selection SI File dialog box.
 - c. Click **OK**. You will receive the "Different Stream ID" warning message.
 - d. Click **Yes** in the warning message window; then click **Edit** in the SDT dialog box.

9. When the table editor opens, change the value of the Transport stream ID text box to **1**.

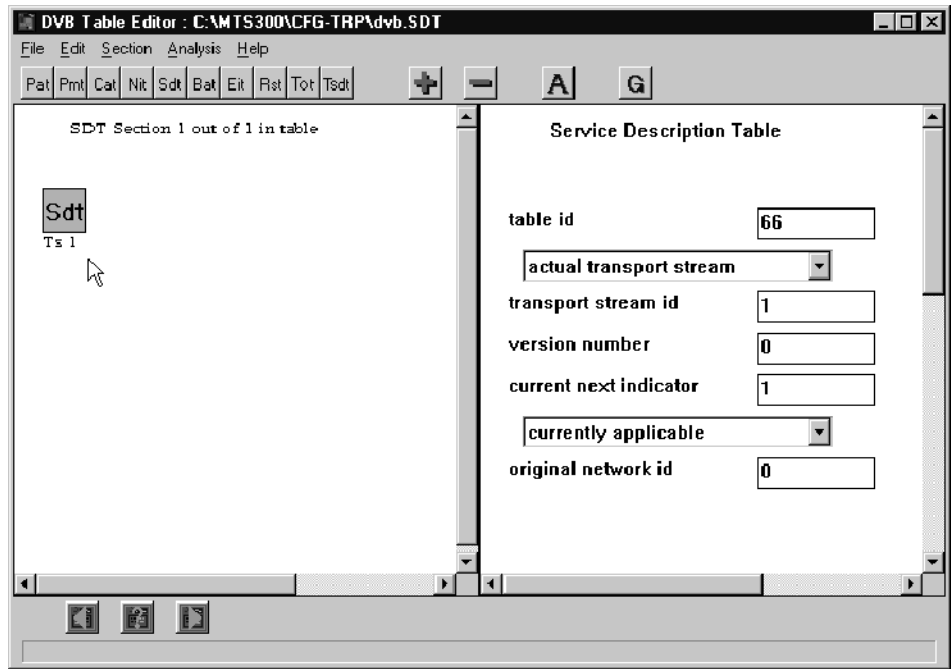

10. Click in the Hierarchy view and note that the text under the SDT icon changes to TS 1.
11. Choose **Save** and then **Exit** from the File menu. Click **OK** in the SDT dialog box. The Transport Stream ID Error message no longer appears.

Edit the EIT In this section, you will edit the EIT using the table editor.

1. Double-click the **EIT** icon to open the EIT dialog box and edit the EIT file.
2. Click **Edit** in the EIT dialog box to start the Table Editor application.
3. Perform an analysis (click the **A** command button).
4. The resulting Messages window contains three warnings and an error message:
 - The service id value is incorrect (Warning)
 - The current next indicator should be “1” (Warning)
 - The last table id value is incorrect (Warning and Error)

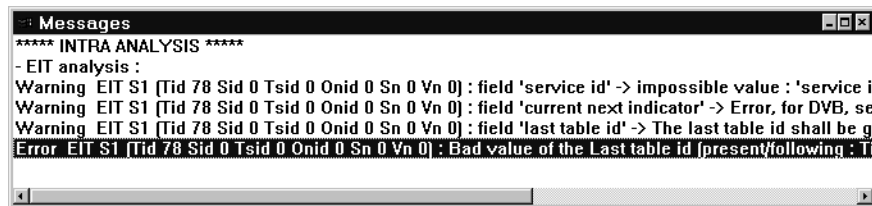

5. Change the Event Information Table current next indicator field to **currently applicable**.
6. Type 78 (the ID of this table) in the last table id text box.
7. Perform an analysis again and note that there is only one message left, which indicates that the the service id should be identical to the Program ID of the associated PMT: Use the following procedure to identify the correct value for the Service ID.
 - a. Click the **PMT** command button on the Table Editor toolbar. The Table dialog box appears.
 - b. Click **Open**, and then select the **dvb.PMT** PMT file (located in C:\MTS300\CFG-TRP).

The table editor changes to show the beginning of the PMT and its values. The Program ID of the first PMT section is 2 as shown in the following illustration.

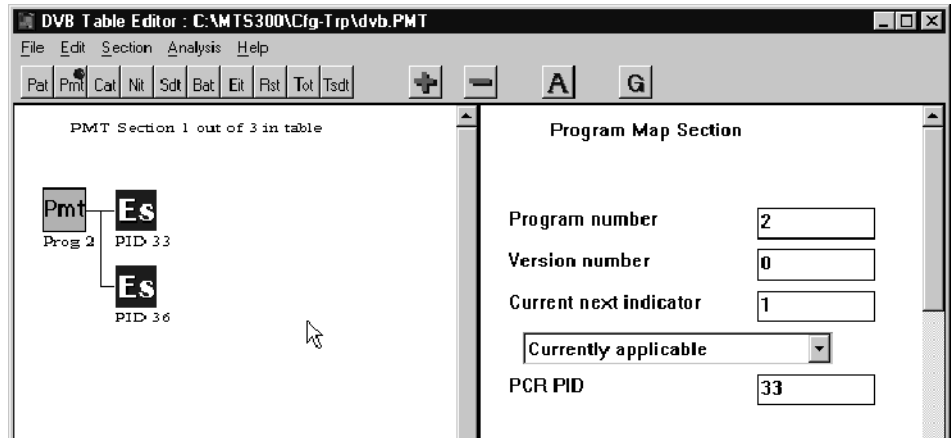

- c. Select **Close** from the File menu to close the PMT file and return to the EIT display.
- 8. In the Edit view of the EIT, change the value of the Service ID text box to **2**, and then click in the Hierarchic view. Note that the text under the EIT icon changes to S 2.

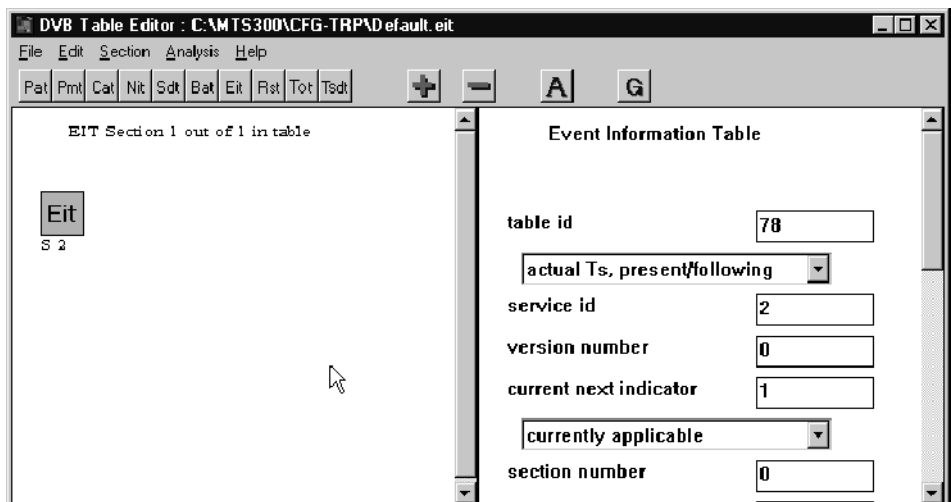

9. Perform an analysis on the EIT to confirm that all reported errors are corrected.

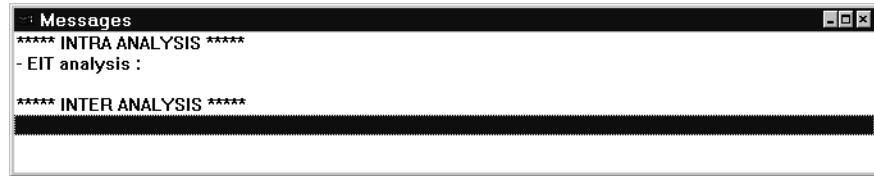

10. Remember that when you first added the Default.EIT to the multiplexer hierarchy, you saw a Transport Stream ID warning message. Correct this error now by entering **1** in the transport stream id text box.
11. Save the EIT as **dvb.EIT** and exit the table editor. The Transport Stream ID error message appears because Default.EIT is still selected.
12. Click **OK** to dismiss the error message; then click **Browse** in the EIT dialog box and select **dvb.EIT** using the Selection SI File dialog box.
13. Click **OK** to accept the selection, and then click **OK** again to dismiss the EIT dialog box.

The SI hierarchy of the multiplexer now appears as shown below:

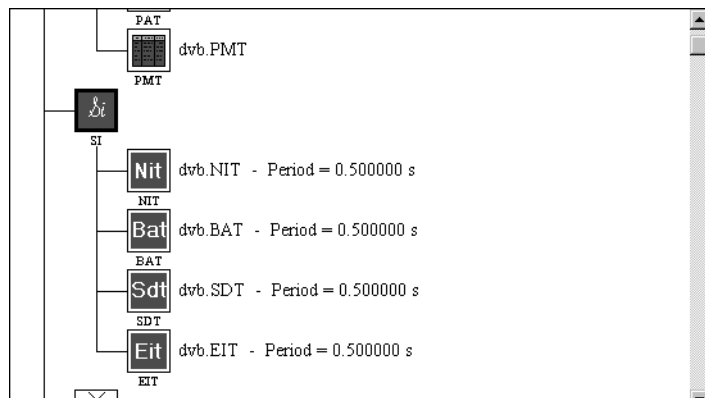

Create TDT Information

The time date table information can be created using the multiplexer alone.

1. Select the **SI** icon, and then click the **+** command button. The following dialog box is displayed.

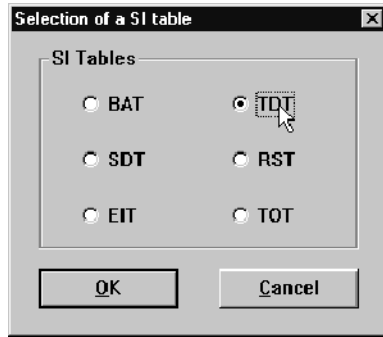

2. Select **TDT**, and then click **OK**. The Time and Date Table dialog box is displayed with the current date, time and default TDT Period displayed in the respective text boxes.

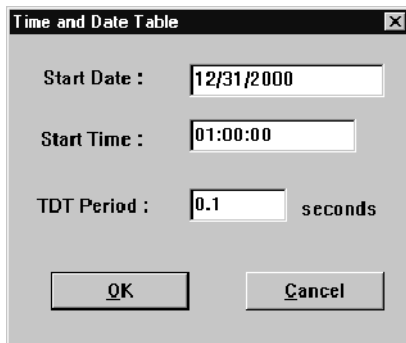

3. Change the values in the text boxes to a future date and time and for a more frequent table period:
 - a. Type 12/31/2000 in the TDT Starting Date text box.
 - b. Type 01:00:00 in the TDT Starting Time text box.
 - c. Type 0.1 in the TDT Period text box. The TDT Period specifies how often the time and date stamp is placed into the transport stream.

NOTE. You can also edit TDT parameters using the DVB Files Selection dialog box shown on page 2-41 (display the dialog box by double-clicking the SI icon). Initially the TDT text boxes are grayed out. In order to edit the date, time, and period values, you must first select the TDT check box in the lower right corner of the dialog box.

4. Click **OK**. The Hierarchic view now shows a TDT icon.

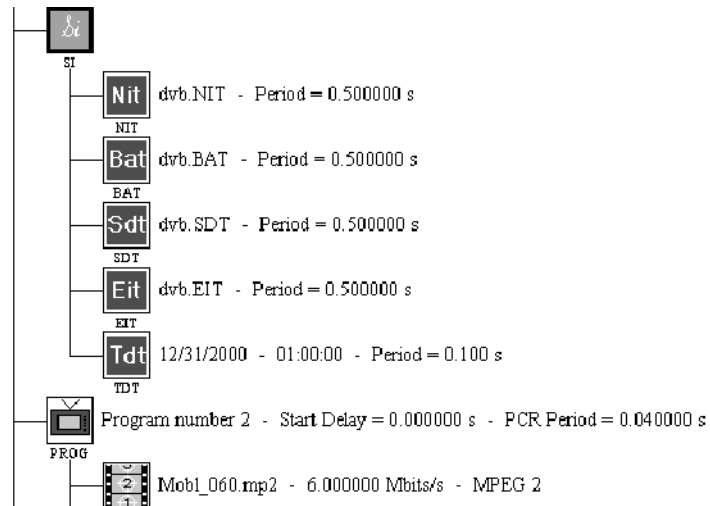

5. Choose **Save** from the File menu (or click the **Save** command button) to save all the changes to the dvb.CFG file.

Create a Set of Complete Tables with DVB Information

So far, you have created a set of coherent tables for the transport stream file you are creating. However, the tables are incomplete because you have included information for only one program: Program 2 (Service 2). Now you need to modify your existing tables to include the other two programs in your configuration file.

You are already familiar with the basic procedures associated with the multiplexer and table editor; therefore, not all of the steps in this part of the tutorial are fully described. If you have trouble completing a basic procedure, see the relevant section of the first or second tutorial. New procedures are described more fully.

Display the DVB Table Editor Global View

In this part of the tutorial, you will use the MTS300 DVB Table Editor to modify the NIT, EIT, and SDT tables and you will learn how to use a new table editor view: the Global view.

1. Double-click the **NIT** icon, and then click the **Edit** button to start the table editor with the `dvb.NIT` table file displayed.
2. Display the NIT, SDT, and EIT in the Global view window:
 - a. Click the **G** command button on the toolbar (or select **Global View** from the File menu). This displays the Global View File Selection dialog box with the NIT file selection showing the `dvb.NIT` file selected.

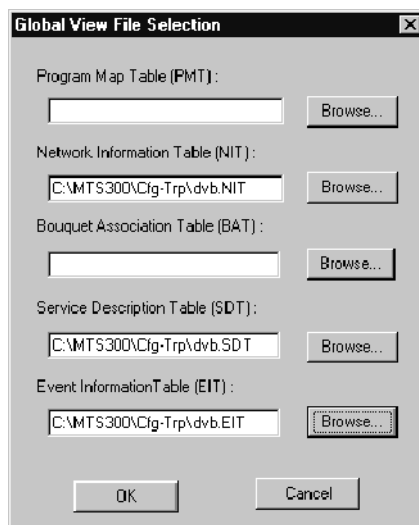

- b. Use the **Browse** buttons to select the `dvb.SDT` and the `dvb.EIT` table files, and then click **OK**. The Global View window is displayed showing the icons for the tables you selected.

3. Arrange the both view windows so that they look similar to the following illustration. It is easier to see the effects of the edits you will be making on the relationships between tables using this arrangement.

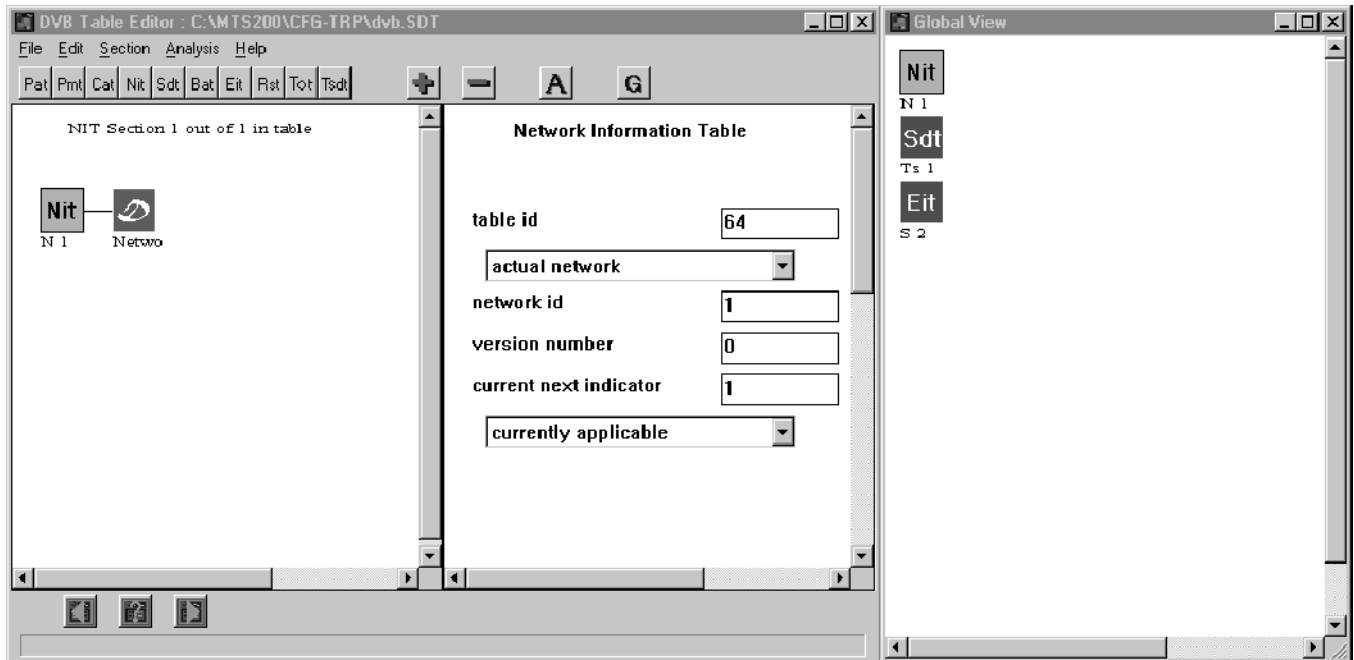

The Global View window shows interrelationships between NIT, SDT, and EIT table files; in this case, there are no apparent relationships. The DVB NIT, SDT, and EIT files are normally associated using the following mechanisms:

- NIT files and SDT files are associated through Transport Stream IDs.
- SDT files and EIT files are associated through Service IDs.
- EIT files and NIT files are associated through Transport Stream ID and the Service ID pairs.

NOTE. *PSIP table file interrelationships are somewhat more complex. See Using the PSIP Table Editor Global View Window on page 3-136 for more information about making table associations for PSIP tables.*

4. Click each of the table icons in the Global view and notice how the Hierarchic view updates to show the selected table each time. The Edit view shows the top level of the selected table.

Create the NIT-SDT Relationship

1. To associate the SDT to the NIT, you need to add a transport stream to the NIT. Click the **NIT** icon in the Global view window.
2. In the Hierarchic view, select the **NIT** icon, then press the **Ins** (Insert) key on your keyboard. This displays the Add dialog box.
3. Select **Transport stream**, and then click **OK**. Notice the addition of the transport stream icon to both the Global and Hierarchic view windows.

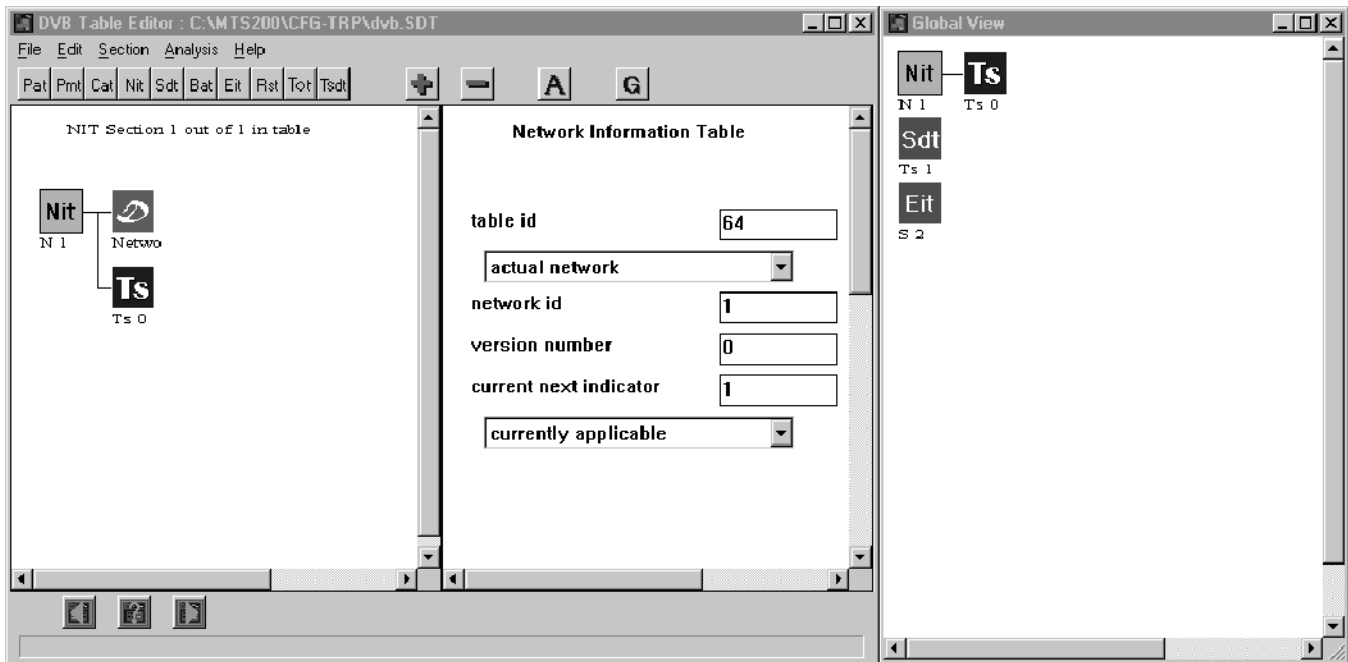

4. In the Global View window, select the **SDT** icon and check the Transport Stream ID value.
5. Click the **TS** icon in the Global view window, and then update the Transport Stream ID text box to **1**.
6. Click in the Hierarchic view and notice the update to the TS icon in both the Hierarchic and Global view windows.
7. Perform an analysis (click **A** on the toolbar).
8. Clear the INTER ANALYSIS warning for the NIT-SDT tables by adding a cable_delivery_system descriptor to the transport stream table element (TS 1 icon). Under normal circumstance you would update the Cable Delivery System parameters with the characteristics of your environment. For the purposes of this tutorial, leave the parameters at their default values.
9. Perform an analysis again and note that the NIT-SDT analysis is clear.

Create the SDT-EIT Relationship

The warning message for the SDT-EIT INTER ANALYSIS indicates that there is no service defined for the Transport Stream ID-Service ID pair.

1. Add a Service and a Service Descriptor to the SDT and change the default values:
 - a. Select the **SDT** icon and press the **Ins** (Insert) key on your keyboard. A service icon is added to the SDT icon.
 - b. Change the Service ID value to **2**, and then select **Present** from the EIT Present Following Flag drop-down selection box.
 - c. Select the Service icon (S2) and click **+** (or press **Ins**), select Descriptor in the dialog box and click **OK**.
 - d. From the drop down list, select service, click the **Add** button, and then click **OK**.
 - e. Click in the Hierarchic view window. The Hierarchic and the Global View windows are updated to reflect the changes you have made.

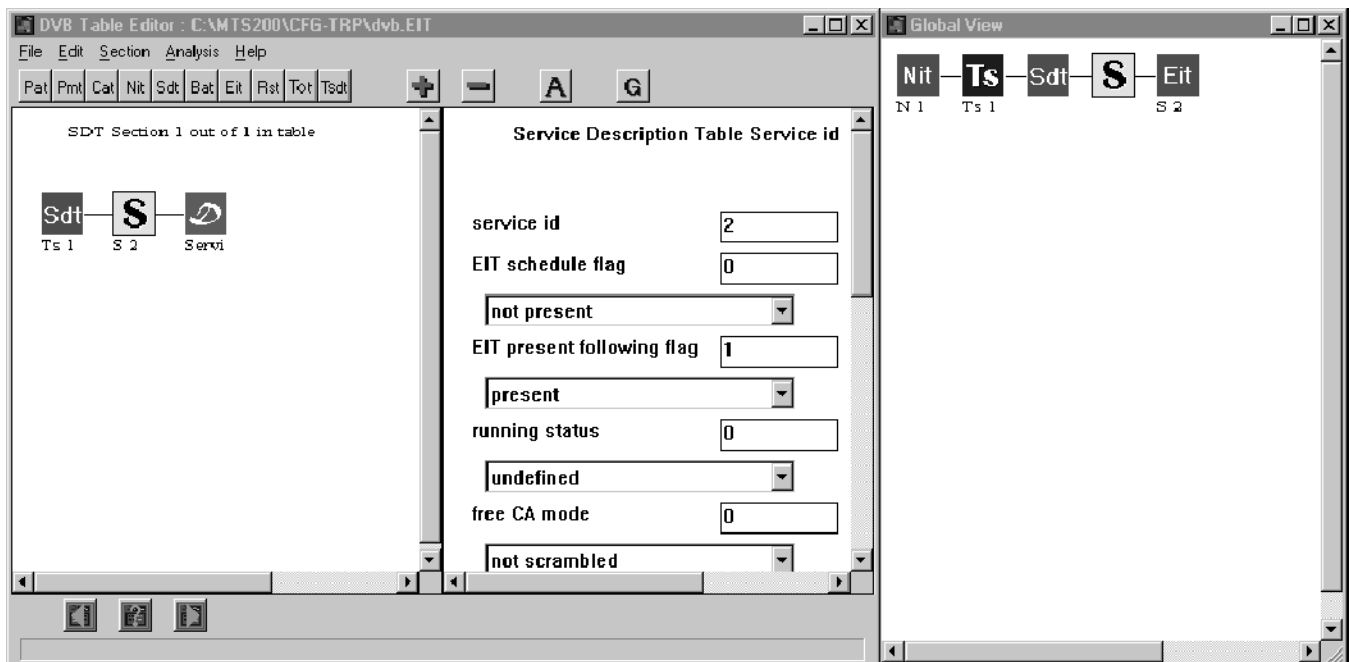

2. Now, add services for the other two programs in your configuration file. (Recall that the Program ID values are found in the PMT.)
 - a. Select the **S** (Service) icon, and press **CTRL-C**. This copies the contents of the service and descriptor icons to the clipboard.
 - b. Select the **SDT** icon and press **CTRL-V** twice. This pastes the service and descriptor icons into the SDT hierarchy.
3. Edit the new services:
 - a. Select the middle service icon and change the Service ID value to 3.
 - b. Select the last service icon and change the Service ID value to 4.
 - c. Click in the Hierarchic view and note that the text under the service icons have changed to S 3 and S 4 respectively.

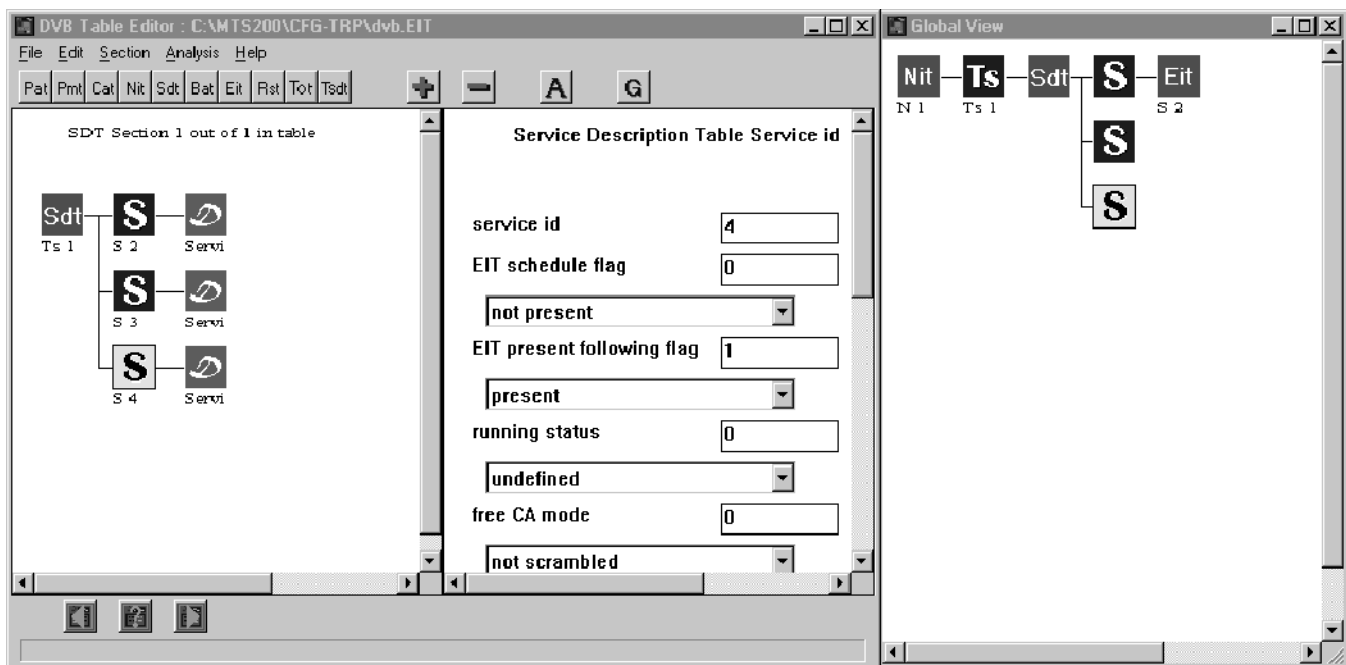

4. Perform an analysis and notice that there are two warnings and an error message.

5. Double-click the error message and add a second section to the EIT by selecting **New** from the Section menu. Update the section parameters as follows:
 - a. For section two, change the following parameters to the values indicated in the following illustration and note the updated Global view display.

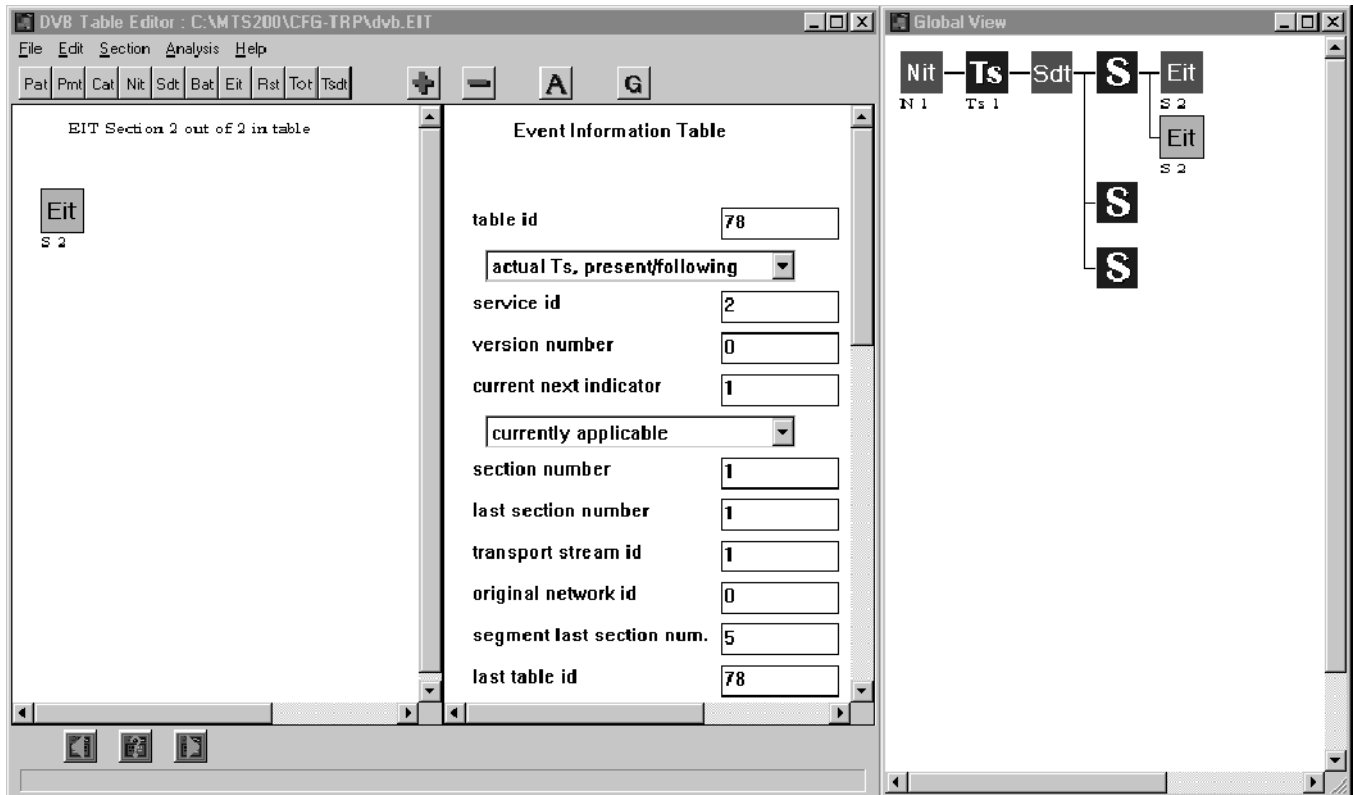

- b. Click the ◀ (Previous) button on the lower toolbar to display the first EIT table section and change the Last Section Number and Segment Last Section Num. to 1 and 5 respectively.
6. You have created a valid set of EIT sections for Service ID 2, now add and update the EIT to create valid sections for services 3 and 4.
 - a. Add four more sections to the EIT. (Note the changes to the Global view window.)
 - b. Change the values for each section as indicated in Table 2-2 (leave the other parameters at their default values).

Table 2-2: EIT parameter values for sections 3 through 6

Parameter	Section 3	Section 4	Section 5	Section 6
Service ID	3	3	4	4
Section Number	0	1	0	1
Last Section Number	1	1	1	1
Transport Stream ID	1	1	1	1
Segment Last Section Num.	5	5	5	5
Last Table ID	78	78	78	78

7. Perform an analysis and note that the inter-analyses are clear. However, now there are three warning messages about the reserved value in the service type field in the SDT.
8. Double-click the top message, and then change the service type to Digital Television (the text box will update to 1); fill in the Provider Name text box with Tektronix and the Service Name text box with SVC2.
9. Repeat step 8 for the other two services, using SVC3 and SVC4 for the Service Name value for the respective services.

10. Click in the Hierarchic view and the display should look like the following illustration.

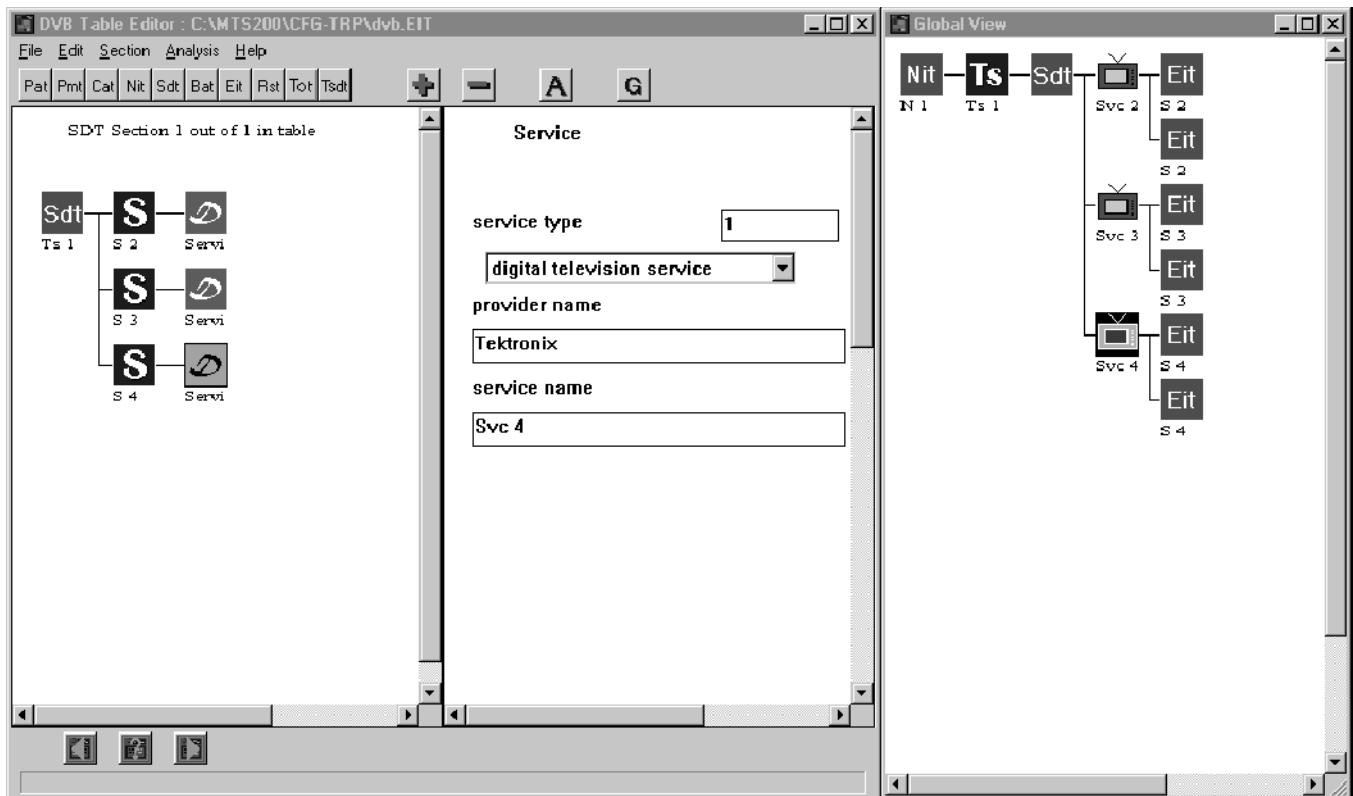

11. Perform an analysis again, noting the fact that there are no further error or warning messages: Save all of the open table files by selecting **Save All** from the File menu.
12. Exit the DVB Table Editor, and then click **OK** in the SDT dialog box.
13. Save the dvb.CFG file in the multiplexer, and then use the procedure described in *Multiplexing the Transport Stream File* on page 2-35 to create the dvb.TRP transport stream file.

This concludes the tutorial for creating an MPEG-2 transport stream file with DVB information. Refer to *Using the DVB and PSIP Table Editors*, beginning on page 3-93, for additional information about using the table editors. See *PSI, DVB SI, and ATSC PSIP Table Item Parameters*, beginning on page 3-143, for complete descriptions of PSI, SI, and PSIP tables, descriptors, and parameters.

You can proceed to *Error Injector Tutorial*, beginning on page 3-227, to learn how to insert errors into the transport stream file you created in this tutorial.

Reference

This section is the reference for the MTS300 MPEG Test System Stream Creation Applications and is organized into the following sections (page references indicate the first page of each section):

- Using the Multiplexer (page 3-3)
- Using Option CA: Scrambling/Conditional Access (page 3-89)
- Using the DVB, PSIP, and ARIB Table Editors (page 3-93)
- PSI, DVB SI, and ATSC PSIP Table Item Parameters (page 3-143)
- Using the Jitter Adder (page 3-191)
- Using the DVB Channel Coder/Decoder (page 3-199)
- Using the TMCC Combiner (page 3-215)
- Using the Error Injector (page 3-225)
- Using the OpenMux Configuration Client (page 3-233)

You can access additional operating information for the applications and information regarding MPEG-2, DVB, and ATSC bit streams from the following sources:

- Online Help. Select Contents from the Help menu.
- MPEG-2 Help. This utility contains much of the ISO/IEC 13818-1 MPEG-2 standard in Windows Help format. Double-click the MPEG-2 Help icon in the Tektronix MPEG Test System program group window.
- Status bar. Located at the bottom of the application windows, the status bar displays brief messages that describe highlighted menu selections.
- ToolTips. ToolTips display the names of active command buttons. Placing your mouse cursor over a command button, and leaving it there for a second, will display the command button name in a small ToolTips window.

Using the Multiplexer

Overview

You can use the MTS300 MPEG-2 DVB / ATSC / ISDB-S Transport Stream Multiplexer to specify the characteristics and contents of an MPEG-2, DVB, ATSC, or ISDB-S/ARIB compliant transport stream. You can then generate a file that contains the transport stream to test MPEG hardware or software components.

Definitions

Multiplexing is the process of combining and arranging program data (compressed video, audio, and data streams with timing information) and overhead (PSI, SI, PSIP, and ISDB-S/ARIB data) so that the data can be transmitted and later decoded. The broadcast or transmitted product of this process is called, variously, a *multiplex* or a *transport stream*.

A *transport stream file* is a digital data structure defined by ISO/IEC 13818-1, tailored to communicate one or more encoded programs according to MPEG-2 standards: the MPEG-2 standard is extended by the DVB, ATSC, and ISDB-S/ARIB standards. The transport stream file data may be broadcast, transmitted, or stored in a computer file as it is on system disks or on the Tektronix MTS300 MPEG Test System data store disks.

When the transport stream file that is broadcast or transmitted in a way designed to be decoded, it is a transport stream.

Conventions

To create a compliant transport stream file using the multiplexer, you must first create a configuration file that contains all the instructions for making the desired transport stream file. The configuration file contains general information about the multiplex you are creating, such as the multiplex rate and any program delays. It also points to (or links to) other required files, such as elementary stream files and PSI, SI, PSIP, and ARIB table files.

When it generates a transport stream file, the multiplexer combines information from the configuration file, elementary stream files, and table files according to instructions contained in a configuration (*.cfg) file. The following illustration depicts the relationships between configuration file and the other elements of the transport stream file you are creating.

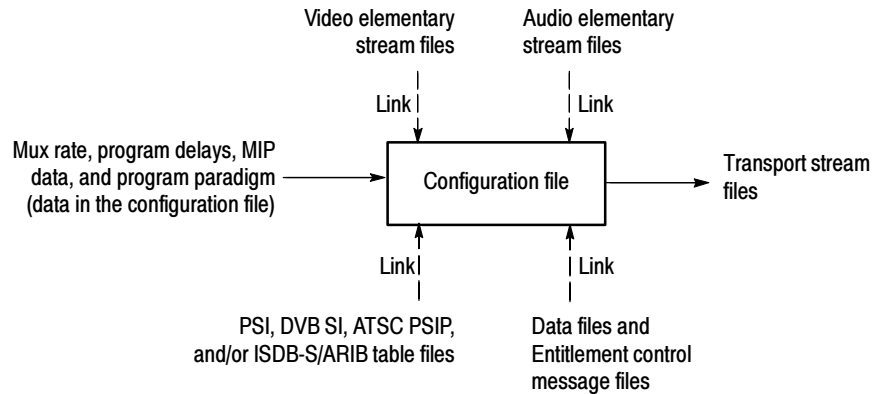

The configuration file is similar in structure to a Windows *.ini file. See the example configuration file at the end of this section, beginning on page 3-85. The configuration file is independent of the transport stream file. It allows you to create transport stream files with only minor variations by using the same base configuration file.

The following steps describe the general procedure for creating a transport stream file with the multiplexer:

1. Create a new configuration file with default information.
2. Select an alternative environment if applicable (DVB, DVB-T, ATSC, or ISDB-S/ARIB).
3. Add stream icons to the first program.
4. Add more programs and stream icons as desired.
5. Associate Video, Audio, and Data files with all stream icons.
6. Add and edit PSI, DVB SI, ATSC PSIP or ISDB-S/ARIB tables.
7. Edit multiplex, tables, and other program parameters as necessary; confirm that the highest actual multiplex rate does not exceed the rate chosen for the multiplex (transport stream) as a whole.
8. Create the transport stream file from the configuration file.

The material in this section assumes that you have familiarized yourself with the multiplexer interface and capabilities using the following tutorials in the *Operating Basics* section (the tutorials progress from creating a simple file to creating a complex DVB file with a set of coherent SI table files):

- *Creating an MPEG-2 Transport Stream File* (page 2-7)
- *Creating a Complex Transport Stream File* (page 2-21)
- *Creating a Configuration File with DVB Information* (page 2-39)

This section describes the view windows, menu selections, and interface elements of the MTS300 MPEG-2 DVB / ATSC / ISDB-S Transport Stream Multiplexer. It also provides detailed descriptions of the functions and capabilities of the multiplexer that allow you to create transport stream files.

The Application Window

The multiplexer application window has a title bar, menu bar, toolbar, and status bar. Once you open a new or existing configuration file, the center workspace is divided into three parts: the duration gauge, the rate gauge, and the multiplex window.

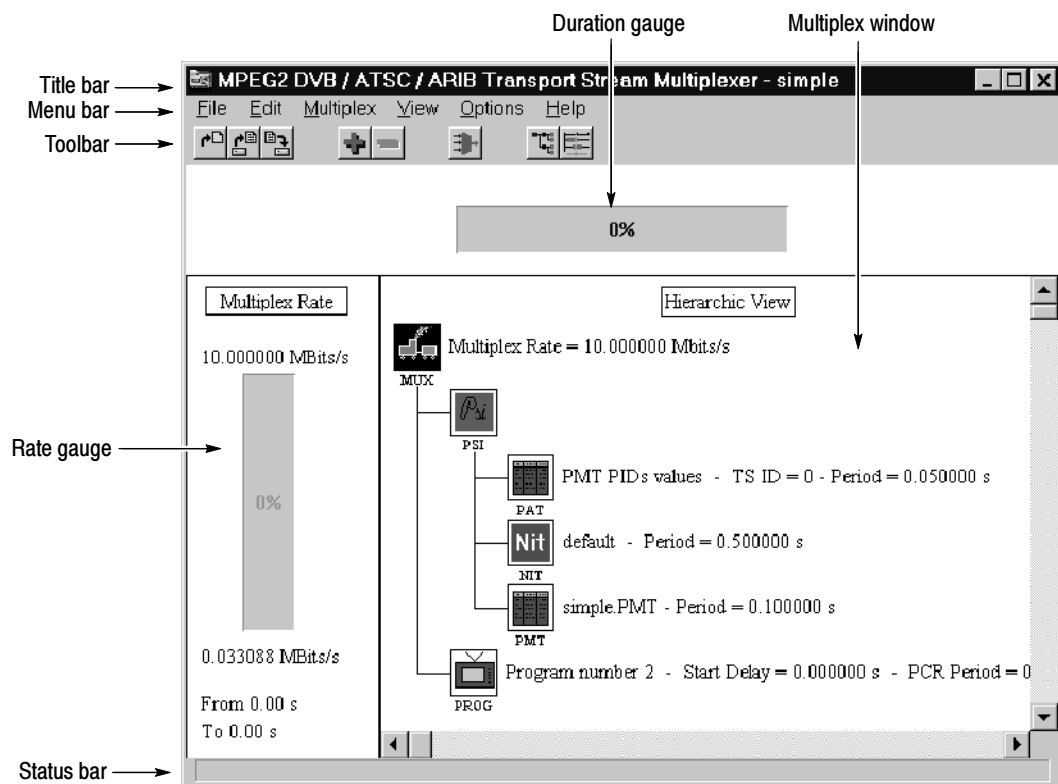

Title Bar The title bar lists the current (displayed) configuration file name, and provides common Windows control buttons to the right.

Menu Bar and Toolbar

The Menu Bar accesses the multiplexer menus. Command buttons on the toolbar provide shortcuts for many menu commands.

File Menu. Use the commands in the File menu (Table 3-1) for creating new files, opening existing files, saving files, closing files, and exiting the multiplexer application. You can choose the **New**, **Open**, and **Save** commands by clicking the equivalent command buttons shown below.



Table 3-1: Multiplexer File menu commands

Use	To
New	Open a new configuration file
Open	Open an existing configuration file
Save	Save the current configuration file
Save As	Save the current configuration file under a new name
Close	Close the current configuration file
Exit	Close the multiplexer application

Edit Menu. Use the Edit menu (Table 3-2) to add and delete items in the configuration file hierarchy. Both commands on the Edit menu have command button equivalents as shown below. In the following illustration, the Delete button is shown in the disabled state (grayed out).



Table 3-2: Multiplexer Edit menu commands

Use	To
Add	Add an item to the multiplex
Delete	Delete the selected item (and any sub-items) from the multiplex

Multiplex Menu. The Multiplex menu (Table 3-3) contains the Go command; choose it or click the equivalent command button shown below to generate a transport stream file (multiplex) from the instructions in the configuration file.



Go (generate
a multiplex)

Table 3-3: Multiplexer Multiplex menu commands

Use	To
Go	Create (generate) a transport stream file from the configuration file

View Menu. Use the View menu (Table 3-4) to select a hierarchic or dynamic display of the configuration file. The menu has two shortcut buttons as shown below.



Hierarchic



Dynamic

Table 3-4: Multiplexer View menu commands

Use	To
Hierarchic	Display a Hierarchic view of the configuration file
Dynamic	Display a timing diagram of the programs listed in the configuration file

Options Menu. For additional information on the Options menu selections (Table 3-5), see *The Multiplexer Environment*, beginning on page 3-20.

Table 3-5: Multiplexer Options menu commands

Use	To
DVB	Toggle DVB required table files (SI) on and off
DVB-T Mega-frame	Toggle DVB Mega-frame information packet on and off
ISDB-S/ARIB	Toggle ARIB table files on and off
Terrestrial ATSC	Toggle terrestrial ATSC table files on and off
Cable ATSC	Toggle cable ATSC table files on and off

Table 3-5: Multiplexer Options menu commands (Cont.)

Use	To
Conditional access license/Scrambling	Enter a password to enable Option CA ¹ (Conditional Access Software). This menu entry replaced by the Scrambling selection following installation.
Dynamic SI	Toggle Dynamic SI on/off
Directories	Configure default directories
Save Environment	Save the current options settings to a file
Load Environment	Read and apply a previously saved environment
Default Environment	Reset all options to the default settings

¹ Refer to *Using Option CA: Scrambling / Conditional Access* on page 3-89 for further information on Conditional Access software.

Help Menu. The Help menu (Table 3-6) provides standard Windows and application-specific information.

Table 3-6: Multiplexer Help menu commands

Use	To
Contents	Open the multiplexer online help
Using Help	Display standard Windows help (about using help)
About...	Display the application version and copyright information

Duration Gauge

The duration gauge is active during multiplex (transport stream) generation only. The gauge shows 0% until you choose the Go command from the Multiplex menu or click the equivalent command button. The gauge then indicates the completed portion of the operation. The gauge returns to 0% when you close the configuration file and later reopen it or when you save the configuration file under a new name. Refer to *Generating a Multiplex*, beginning on page 3-84, for more information.

Rate Gauge

The rate gauge shows the portion of available transport stream capacity that is used for program data and overhead. The target maximum multiplex rate appears above the gauge. The highest actual rate appears below the gauge. For the default MPEG-2 environment, the actual rate is calculated with the following formula:

$$\text{Rate} = \text{PSI rate} + \text{Video rate} + \text{Audio rate} + \text{Data rate}$$

If you have selected DVB, DVB-T Mega-frame, ISDB-S/ARIB, and/or ATSC environments, the SI, ARIB, PSIP, and/or MIP rates, respectively, are also used to calculate the actual rate.

Below the actual rate is the time period during which the highest multiplex rate occurs.

NOTE. *The actual rate and the time it occurs represents the worst case for the resulting transport stream. To see the rate across the entire transport stream, change to the Dynamic view: refer to The Dynamic View on page 3-16 for more information.*

The color of the rate gauge bar depends on the portion of the available rate used by the highest actual rate as listed in Table 3-7.

Table 3-7: Multiplex rate gauge colors

Actual rate/maximum rate	Bar color
0 to 69%	Green
70% to 89%	Yellow
90% and above	Red

You can create and save a configuration file with greater than 100% multiplex rate usages; however the application warns you of multiplex overflow if you attempt to generate a transport stream from such a configuration.

Multiplex Window

You can display the current configuration file in the Multiplex Window in either the Hierarchic or Dynamic view. The Hierarchic view is a graphic representation of the transport stream configuration that uses icons to show the interrelationship of stream components. The Dynamic view shows the timing relationships between the various programs in the transport stream; it is useful for seeing how programs use the available multiplex rate and for resolving timing conflicts.

Status Bar

The status bar provides brief messages about menu selections as you highlight them.

The Hierarchic View

The Hierarchic view uses icons to show the interrelationship of transport stream components and is the workbench for assembling and editing transport stream configuration files. When you create a new configuration file or open an existing one, the configuration appears in the Hierarchic view, as shown below.

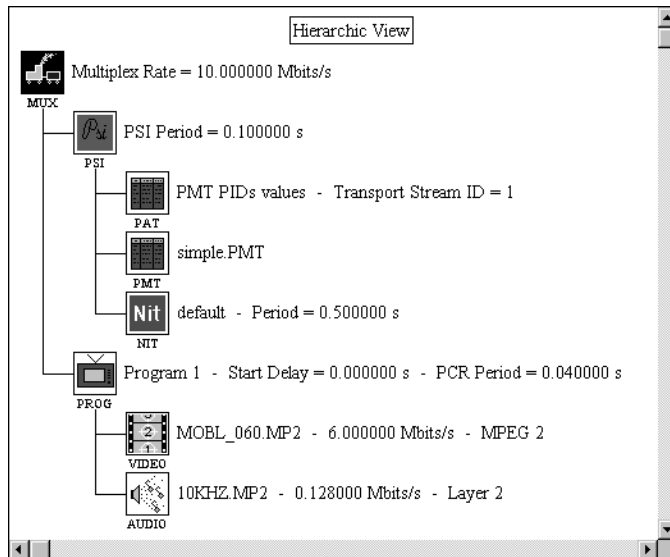

Hierarchy Icons

Each transport stream item (tables, programs, elementary streams) is represented in the Hierarchic view by a unique icon. Table 3-8, beginning on page 3-11, lists and explains the icons and actions you can perform by clicking the icon with either mouse button. The icons are arranged in the following order (which is generally the order in which they appear in the Hierarchic View):

- Multiplex icon
- PSI table icons
- SI table icons
- PSIP table icons
- ISDB-S/ARIB table icons
- MIP icon
- Program icons

Some items (and their icons) apply only to DVB, ISDB-S/ARIB, or ATSC streams and appear only when DVB, ISDB-S/ARIB, or ATSC options are selected from the Options menu; refer to *Changing Environment Options* on page 3-21 for more information. The CAT icon, and the icons associated with the CAT (EMM and ECM), are discussed in *Using Option CA: Scrambling/Conditional Access*, beginning on page 3-89.

Table 3-8: Hierarchic view icons







Icon	Item	Double-click to	Right-click to
 MUX	Multiplex. This is the main icon for the configuration file. Required.	Set multiplex rate and start time.	Collapse/expand the hierarchy at this icon.
 PSI	Program Specific Information (PSI). MPEG-2 decoders use PSI when demultiplexing the programs in a transport stream. Required.	Set the PSI period.	Collapse/expand the PSI table hierarchy at this icon.
 PAT	Program Association Table (PAT). The PAT provides the correspondence between each program in the stream and the PMT that describes the program. The PAT is always identified with PID 0. Required.	Read and set the PIDs of associated tables and programs.	No
 PMT	Program Map Table (PMT). The PMT specifies a PID value for each elementary stream associated with the program and describes the program components. Some transmission systems (such as ATSC and DVB) require specific PID values. Required.	Edit the PMT (with the Edit Table application).	No
 TSDT	Transport Stream Description Table. The TSDT provides a description of all the components of a transport stream. Optional.	Edit the TSDT (with the DVB Table Editor application).	No
 CAT	Conditional Access Table. The CAT table allows you to associate one or more conditional access systems with the transport stream. Optional.	No	Collapse/expand the EMM table at this icon
 EMM	Entitlement Management Message. Each CAT must have at least one EMM icon associated with it. An EMM specifies the conditions under which a program element can be unscrambled. Optional.	Select or edit the EMM stream file and conditional access parameters.	No

Table 3-8: Hierarchic view icons (Cont.)











Icon	Item	Double-click to	Right-click to
 SI	Service Information (SI). SI consists of up to six tables (NIT, BAT, SDT, EIT, TOT, and TDT) and provides information on services and events carried by this multiplex, different multiplexes, and even on other networks. Required for DVB configuration files.	Add or edit DVB table files (NIT, BAT, SDT, TOT, and EIT); set TDT parameters.	Collapse/expand the SI table hierarchy at this icon.
 NIT	Network Information Table (NIT). The NIT provides information about the physical network. Optional under MPEG-2 standards, but required by the multiplexer in DVB and MPEG-2 modes; found under the PSI icon for non-DVB and under the SI icon for DVB configurations. Not required for ATSC configurations.	Select or edit the NIT file and set the NIT period.	No
 BAT	Bouquet Association Table (BAT). The BAT provides information regarding service bouquets (collections of services that are marketed as single entities). Optional (DVB only).	Select or edit the BAT file.	No
 SDT	Service Description Table (SDT). The SDT contains data describing the services in the system such as names of services, the service provider, etc. Optional (DVB only).	Select or edit the SDT file.	No
 EIT	Event Information Table (EIT). The EIT contains data concerning events and programs (a concatenation of one or more events under the control of a broadcaster), such as event name, start time, or duration. Optional (DVB or ATSC only).	Select or edit the EIT file.	No
 TDT	Time and Date Table (TDT). The TDT provides the UTC time and data information. Optional (DVB only).	Set TDT parameters.	No
 RST	Running Status Table (RST). The RST gives the status of an event (running or not running). Optional (DVB only).	Select or edit the RST file.	No
 TOT	Time Offset Table (TOT). The TOT provides information relative to the actual date and time. Optional (DVB only).	Select or edit the TOT file.	No
 DIT	Discontinuity Information Table (DIT). Optional (DVB only).	Select or edit the DIT file.	No
 SIT	Selection Information Table (SIT). Optional (DVB only).	Select or edit the SIT file.	No

Table 3-8: Hierarchic view icons (Cont.)



















Icon	Item	Double-click to	Right-click to
 PSIP	Program and System Information Protocol (PSIP). Decoders use PSIP tables to accurately de-multiplex the ATSC transport streams in which the tables are carried. Optional (ATSC only).	Set the period for PSIP tables.	Collapse/expand the PSIP table hierarchy at this icon.
 VCT	Virtual Channel Table (VCT). The VCT (TVCT or CVCT for terrestrial and cable ATSC respectively) defines the attributes of the MPEG-2 programs embedded in the transport stream file. A service_location_descriptor needs to be present for each virtual channel in the VCT. Optional (ATSC only).	Select or edit the VCT file and set the period for the VCT.	No
 MGT	Master Guide Table (MGT). The MGT defines the types, PIDs, and versions of the PSIP tables carried in the transport stream (except the system time table). Optional (ATSC only).	Select or edit the MGT file and set the period for the MGT.	No
 RRT	Rating Region Table (RRT). The RRT defines the parental guidelines system for different regions. The RRT is referenced by content advisory descriptors carried in the transport stream. Optional (ATSC only).	Select or edit the RRT file and set the period for the RRT.	No
 STT	System Time Table (STT). The SST provides the current time and date. Optional (ATSC only).	Select or edit the STT file and set the period for the SST.	No
 ETT	Extended Text Table (ETT). The ETT provides optional text messages that can be used to describe the virtual channels and events carried in the transport stream. Optional (ATSC only).	Select or edit the ETT file and set the period for the ETT.	No
 MIP	Mega-frame Initialization Packet (MIP). The MIP defines the start of the mega-frame and the transmission characteristics of the DVB-T (terrestrial DVB) transport stream. Optional (DVB-T Mega-frame only).	Set the MIP parameters and add/remove transmission power, and time and frequency offset functions.	No
 ARIB	Association of Radio Industries and Businesses (ARIB).	Set the periods for ARIB tables.	Collapse/expand the ARIB table hierarchy at this icon.
 DLT	Download Table (DLT) Optional (ARIB)	Select or edit the DLT file and set the period and PID for the DLT.	No

Table 3-8: Hierarchic view icons (Cont.)

Icon	Item	Double-click to	Right-click to
	Broadcaster Information Table (BIT) Optional (ARIB)	Select or edit the BIT file.	No
	Download Control Table (DCT) Optional (ARIB)	Select or edit the DCT file.	No
	Software download trigger table (SDTT) Optional (ARIB)	Select or edit the SDTT file.	No
	Program. A multiplex can have up to 40 programs. Required. Each transport stream must have at least one program with at least one elementary stream.	Set the PCR period and program start delay.	Collapse/expand the hierarchy of program items at this icon.
	Video Elementary Stream. A program may have up to 5 video elementary streams and up to 20 elementary streams of all types. Optional (although each program must have at least one elementary stream).	Select a video elementary stream or set stream parameters.	Collapse/expand the video splice icon (if present) at this icon.
	Video Elementary Stream Splice. The splice icon allows you to insert one video splice into a video stream. Optional.	Select a video elementary stream or set stream parameters.	No
	Audio Elementary Stream. A program may have up to 10 audio elementary streams and up to 20 elementary streams of all types. Optional (although each program must have at least one elementary stream).	Select an audio elementary stream or set stream parameters.	No
	Data Elementary Stream. A program may have up to 10 data elementary streams and up to 20 elementary streams of all types. Optional (although each program must have at least one elementary stream).	Select a data file or set stream parameters.	No
	Entitlement Control Message. An ECM specifies the control words and other system specific parameters used with scrambled elementary streams. Optional.	Select an ECM file or set conditional access parameters.	No

Collapsing and Expanding the Hierarchy

You can expand or collapse the hierarchy structure of several items in the Hierarchic view by right-clicking various icons.

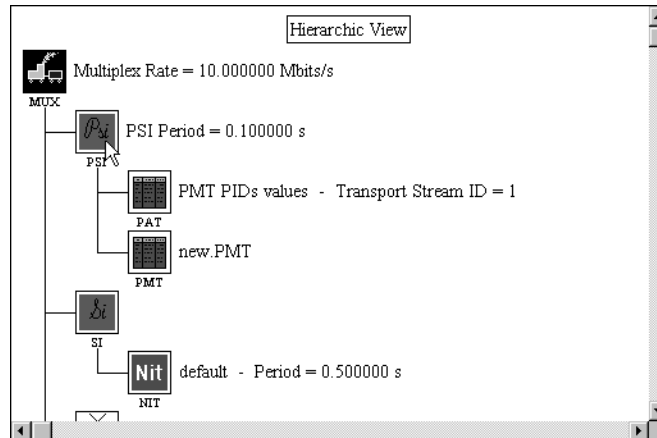

As shown in the following illustration, if you right-click the PSI icon, the PSI hierarchy collapses at that icon, hiding the icons for the PSI tables that will be carried in the transport stream. This function can be useful if you are working with large numbers of programs that have many elementary streams. To restore the hierarchy to its original appearance, right-click the icon a second time.

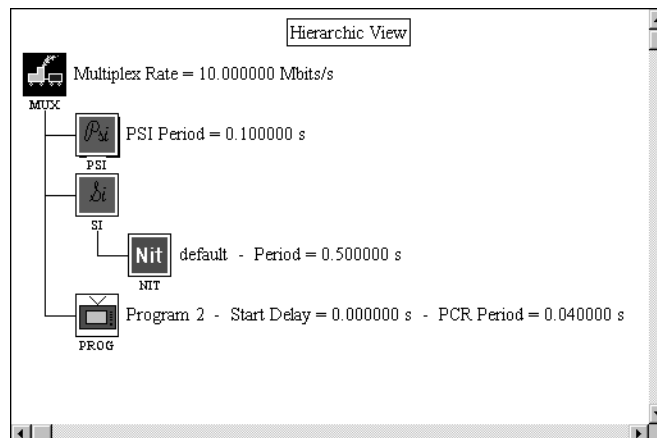

The Dynamic View

The Dynamic view shows the timing relationships of all programs in the multiplex. You can use this view to visualize these relationships, or to help you determine program start delay, or elementary stream initial delay values. Use these parameters to optimize your configuration file.

Understanding and Using the Dynamic View

To display the Dynamic view, select the Dynamic view button on the toolbar, or select Dynamic from the View menu. The Hierarchic view window changes to the Dynamic view.

NOTE. With the Dynamic view displayed, the rate gauge shows the actual multiplex rate of the transport stream at the time indicated by the cursor position.

The following figure shows the Dynamic view for a configuration file that has five programs, each with its start time delayed one second after the end of the previous program. The programs that make up the multiplex are shown as narrow bars, each on its own time line. The duration, starting time, and ending time of each program is approximated by the length and horizontal position of the individual program bars.

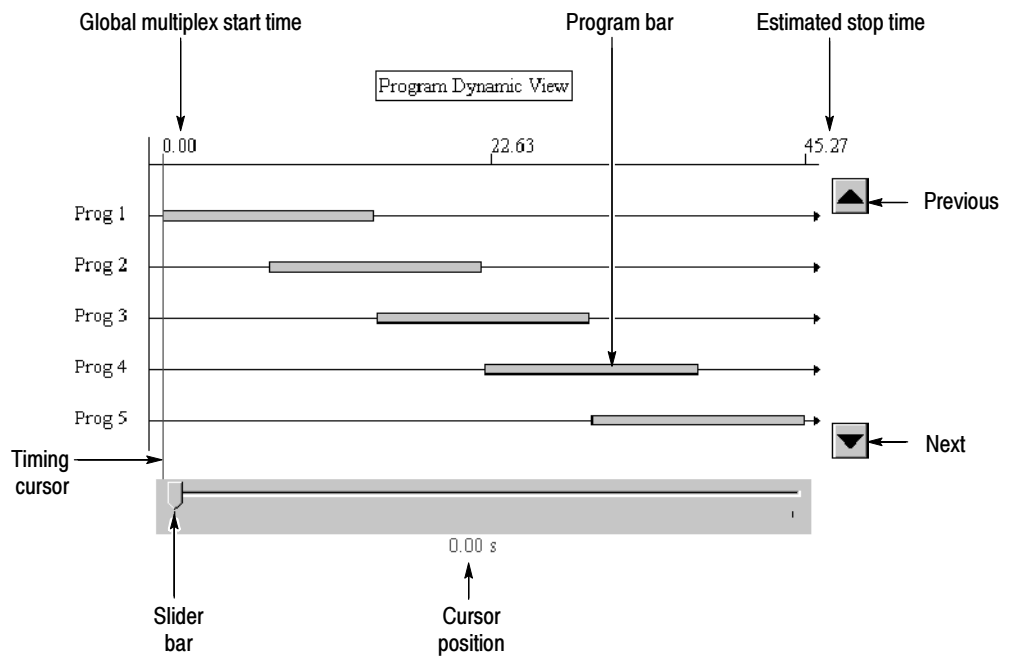

Global Multiplex Start Time. The global multiplex start time is the system clock time at the beginning of the transport stream. Double-click the Multiplex icon (in the Hierarchic view) to set this value.

Estimated Stop Time. The estimated stop time indicates the ending time for the multiplex; that is, the time when all elementary streams for all programs have been sent relative to the system clock plus the global multiplex start time.

Program Bar. The program bar indicates the timing relationships of the programs relative to the entire multiplex (from global multiplex start time to estimated stop time). Double-click a program bar to open a message window containing program timing values. You can use this information to determine precise program delay values for following programs.

NOTE. In some cases, the Program number message window does not display properly. Usually this occurs when the message window, if displayed, would overlay the gray area surrounding the slider bar at the bottom of the Dynamic view window. Try maximizing the multiplexer application window or scrolling the program bar for which you want to display the message window away from the bottom of the Dynamic view window. Use the Up and Down arrow buttons to scroll the program bars.

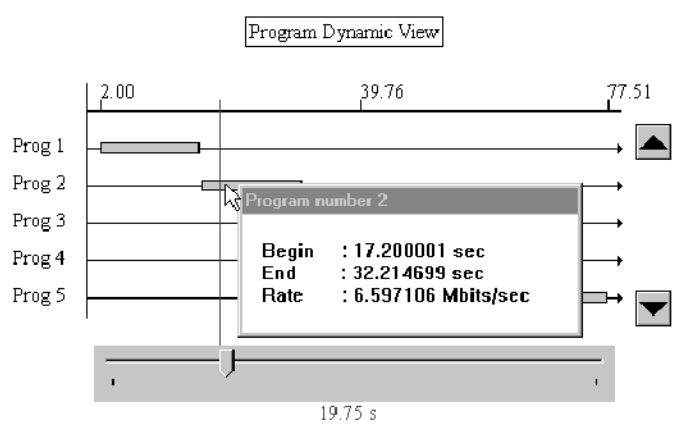

Move this message window by clicking and dragging the title bar. Click anywhere else in the multiplex window to dismiss the value message window.

Timing Cursor. The timing cursor is used to determine the instantaneous multiplex rate of your configuration file. As you move the cursor, the rate gauge, to the left of the Dynamic view, changes to reflect the multiplex rate at the time

represented by the cursor position. Use the following techniques to move the timing cursor:

- Use the slider bar to drag the cursor to a desired position.
- Click on either side of the slider bar to move the cursor one second at a time. After you have clicked in the gray area around the slider bar (you need to do this once each time you display the Dynamic view window), you can move the cursor using one of the following techniques:
 - Press the **Page Down** key on your keyboard to move the cursor one second to the right; press the **Page Up** key to move it one second to the left.
 - Press the **Home** key on your keyboard to move the cursor to the global multiplex start time; press the **End** key to move it to the end of the multiplex.
 - Use the right and left arrow keys on your keyboard to move the timing cursor 0.01 seconds at a time.

Slider Bar. Use the slider bar to drag the timing cursor across the Dynamic view to an approximate position in the multiplex/configuration file. Use one of the techniques described above to move the cursor in 1 s or 0.1 s increments. As you drag the slider bar across the Dynamic view, notice how the multiplex rate gauge responds to the position of the cursor.

Cursor Position. The cursor position indicates the position of the timing cursor in the multiplex relative to time equal to zero. If the global multiplex start time is set to 2 seconds, then the cursor position, when you drag it completely to the left, is 2.00 s. You can use this indicator to help you determine what your program start time, or elementary stream initial delay values need to be in order to optimize your multiplex.

Previous. The Dynamic view can display up to five program bars at once. If there are more than five programs in the multiplex, click this button to display the program (if any) with the next lower number.

Next. If there are more than five programs in the current multiplex, click this command button to display the program (if any) with the next higher number.

Setting Timing Offsets

The multiplexer lets you set three timing offsets: global multiplex start time, program start delay, and elementary stream initial delay.

Global Multiplex Start Time. The global multiplex start time is the system clock time at the beginning of the transport stream. Double-click the Multiplex icon (in the Hierarchic view) to set this value.

Program Start Delay. The program start delay is the lapsed time between the start of the multiplex and the start of the selected program. Program packets are not transmitted until the time indicated by the program start delay.

Set the program start delay by double-clicking the Program icon in the Hierarchic view. Change the value in the Program Start Delay text box, and then click OK to accept your change and close the Program Parameters dialog box. Click Cancel at any time to close the dialog box without making any changes.

Elementary Stream Initial Delay. The elementary stream delay determines the time between the start of the program and the start of the elementary stream in the transport stream. The net effect of the elementary stream delay is to lengthen the duration of the program; it does not decrease the multiplex rate, because null packets are transmitted during the initial delay period.

Set the initial delay value by double-clicking a Video, Audio, or Data icon for the elementary stream you want to change. Change the value in the Elementary Stream Initial Delay text box, and then click OK to accept your change and close the dialog box. Click Cancel at any time to close the dialog box without making any changes.

You can see the effects of all three delays in the following Dynamic view, which shows the timing relationships of three identical programs.

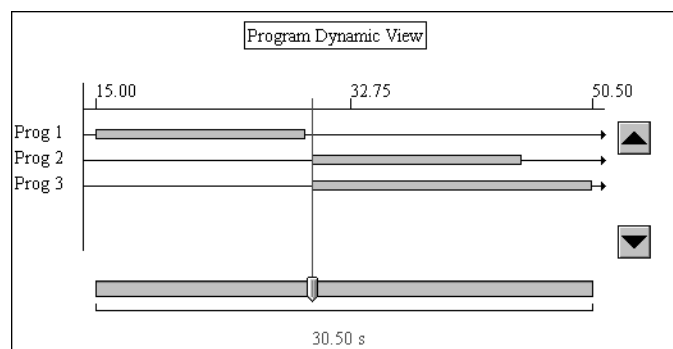

In this illustration, the global multiplex start time is 15.00 seconds, programs 2 and 3 have 15.5 second program start delays, and the video elementary stream in program 3 has a 5 second initial delay.

The following diagram shows the relationship between packet timing delays and multiplexer execution.

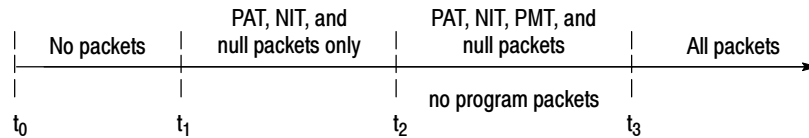

Where:

- t_0 = the 27 MHz system clock (clock-on-the-wall) is zero.
- t_1 = the global multiplex start time, which is set in conjunction with the total bit rate.
- t_2 = the program start delay, which is set for each program.
- t_3 = the elementary stream initial delay, which is set for each video, audio, or data elementary stream.

The Multiplexer Environment

To prevent confusion with transport stream configurations and configuration files, this section refers to the multiplexer application settings as the *environment* rather than the more familiar *configuration*. You can change, save, and restore environment settings using the commands in the Options menu.

Changing Environment Options, beginning on page 3-21, describes how to change various multiplexer environment options. *Saving and Loading Multiplexer Environments*, beginning on page 3-29, describes how to save and load saved environment options.

Many environment options are saved when you exit the multiplexer application and restored the next time you launch it. However, the DVB, DVB-T Megaframe, ISDB-S/ARIB, Terrestrial and Cable ATSC, and Dynamic SI settings become part of the configuration file when you save it.

Changing Environment Options

The following six Options menu selections allow you to set the multiplexer environment:

- DVB. See *The DVB Environment* beginning on this page.
- DVB-T. See *The DVB-T Mega-frame Environment* beginning on page 3-23.
- ISDB-S/ARIB. See *The ISDB-S/ARIB Environment* beginning on page 3-25.
- Terrestrial ATSC. See *The Terrestrial and Cable ATSC Environments* beginning on page 3-26.
- Cable ATSC. See *The Terrestrial and Cable ATSC Environments* beginning on page 3-26.
- Dynamic SI. See *Dynamic SI* beginning on page 3-27.
- Directories. See *Directories* beginning on page 3-28.

NOTE. *If you have Conditional Access installed on your system, the Scrambling environment option is also present. See Using Option CA: Scrambling/Conditional Access beginning on page 3-89 for more information about changing this option and how to create scrambled streams.*

The DVB Environment. The DVB (Digital Video Broadcasting) option determines whether DVB Specific Information (SI) can be added to the configuration file. SI exists in the NIT and several other tables that are encoded into the multiplex (transport stream). The SI tables contain information regarding services and events carried on the current multiplex as well as different multiplexes or different networks.

The DVB SI tables are briefly described in the following list:

- NIT (Network Information Table). The NIT provides information about the physical network. This table is required by the multiplexer. (It appears under the PSI icon in non-DVB mode.)
- BAT (Bouquet Association Table). The BAT provides information regarding bouquets (collections of services marketed as a single item).
- SDT (Service Description Table). The SDT contains data describing the services in the system, for example, the name of the services and service provider.
- EIT (Event Information Table). The EIT contains data concerning events and programs (a concatenation of one or more events under the control of a broadcaster), such as event name, start time, and duration.

- TDT (Time and Date Table). The TDT contains information relating to the current time and date.
- RST (Running Status Table). The RST allows the timing status of one or more event to be accurately and rapidly updated.
- TOT (Time Offset Table). The TOT provides UCT time and local offset information.

To set the DVB environment, select DVB from the Options menu. When you toggle the DVB option on, the SI icon appears in the hierarchy with the NIT beneath it, as shown in the following illustration. This is the default DVB Hierarchic view.

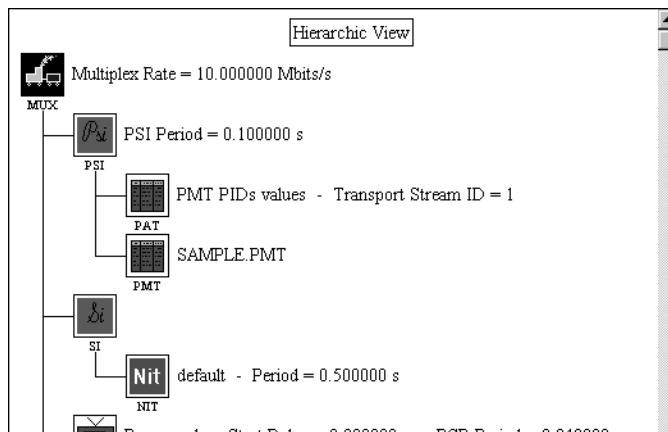

Refer to *Adding and Editing SI Tables*, beginning on page 3-52, for more information about adding other SI tables to the configuration.

toggling the DVB option off when the hierarchy contains no DVB specific tables removes the SI icon and the NIT appears under the PSI icon. However, if you added SI tables, the following warning message appears.

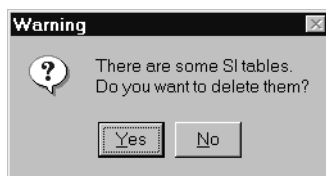

If you click Yes, the SI table references are removed from the configuration file and the icons are removed from the Hierarchic view; however, the table files themselves are not deleted or changed. If you click No, the multiplexer remains in DVB mode.

The DVB-T Mega-frame Environment. The DVB-T (DVB Terrestrial) Mega-frame option adds a Mega-frame Initialization Packet (MIP) to the transport stream hierarchy. The information in the MIP identifies the start of the next DVB-T mega-frame, and it provides DVB-T mega-frame synchronization information for terrestrial single frequency networks (SFN). The MIP also allows you to identify various transmission parameters for the mega-frame and describe various functions for unique transmitters in a network.

To add a MIP icon to the Hierarchic view, select DVB-T Mega-frame from the Options menu.

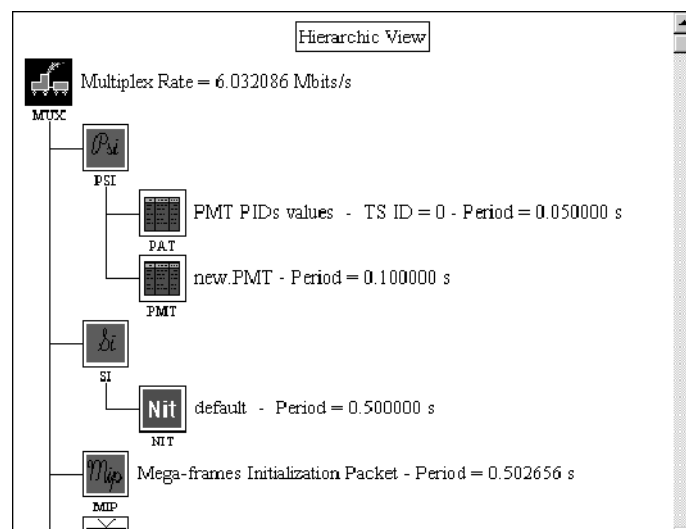

Selecting the DVB-T Mega-frame environment changes the target multiplex rate for the configuration file to 6.032 Mbps (megabits per second) when the defaults seen in the following illustration are used. (the rate increases to 31.668 Mbps when the code rate is 7/8 and QAM64 is selected.)

Unlike other multiplexer items, you do not associate a MIP file with a MIP icon. The MIP is created when you multiplex the configuration file, and you specify MIP parameters using the MIP Parameters dialog box shown below. To access the MIP Parameters dialog box, double-click the MIP icon in the Hierarchic view.

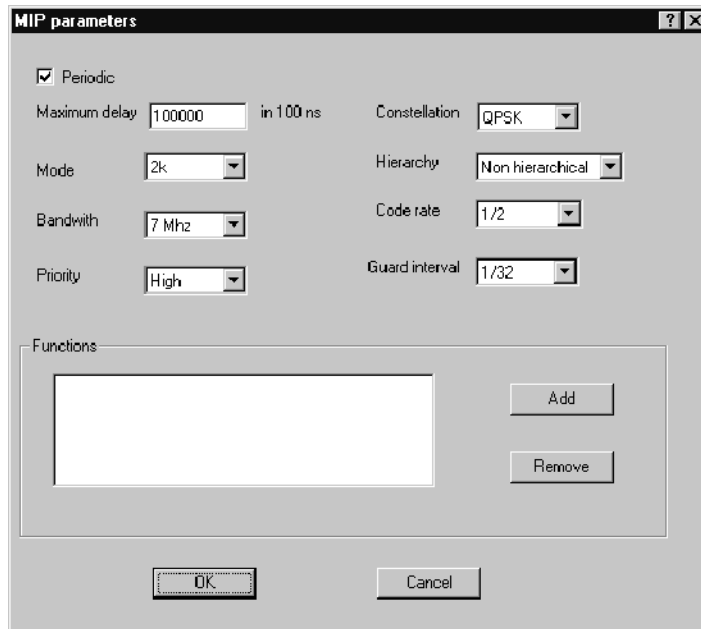

To remove a MIP from the hierarchy, select DVB-T Mega-frame from the Options menu. This removes the icon from the hierarchy, and when you create a multiplex from the configuration file, the MIP will not be generated.

See *Adding and Editing DVB-T MIP Parameters* beginning on page 3-56 for more information about MIP parameters and how to edit them.

The ISDB-S/ARIB Environment. The ISDB-S/ARIB environment option adds an ARIB icon (Association of Radio Industries and Businesses) to the hierarchic view. The ARIB table icon allows you to add ARIB tables to your configuration file.

To create an ISDB-S/ARIB environment, select the environment from the Options menu. The following illustration shows an unedited Hierarchic view after selecting the ISDB-S/ARIB environment option.

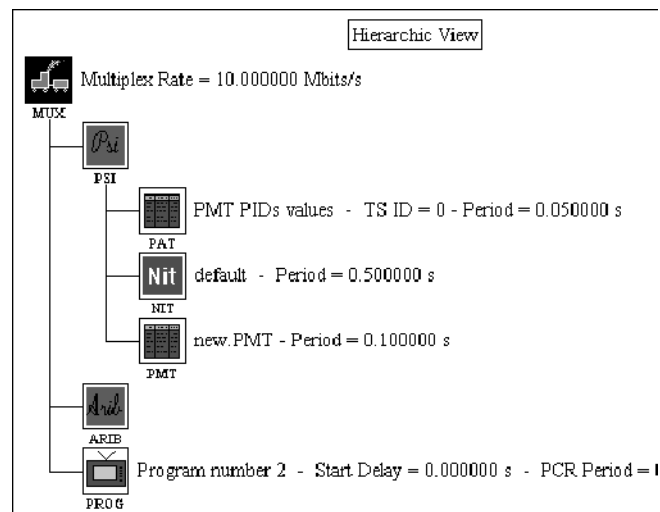

To remove an ISDB-S/ARIB environment file from your configuration file, select the checked option in the Options menu. A warning message is displayed indicating that they are ARIB tables present in the configuration file. Select Yes to delete the tables from the configuration file and to remove the associated icons from the hierarchy (the ARIB table files remain unchanged on your disk). Select No to cancel the environment change.

The Terrestrial and Cable ATSC Environments. Both the Terrestrial and Cable ATSC environment options add a PSIP icon (Program and System Information Protocol) and several PSIP table icons to the Hierarchic view. The PSIP table icons allow you to associate PSIP tables with your configuration file. Selecting an ATSC environment also changes the target multiplex rate for the configuration file (19.392 Mbps for terrestrial or 38.785 Mbps for cable).

To create a terrestrial or cable ATSC environment for your configuration file, select the appropriate environment from the Options menu. The following illustration shows an unedited Hierarchic view after selecting the Terrestrial ATSC environment option.

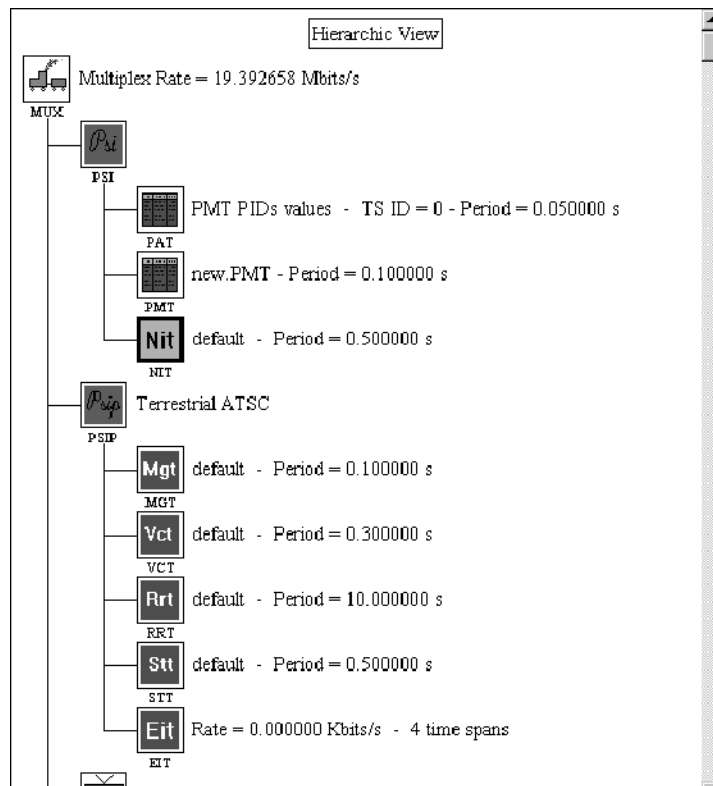

NOTE. The terrestrial and cable ATSC options are mutually exclusive; you can use only one of the ATSC environments for a particular configuration file. You can, however, apply the DVB environment and one of the ATSC environments to a configuration file. PID conflicts are resolved as described in the ATSC document Harmonization with DVB SI in the ATSC Digital Television Standard, Doc A/58.

To remove a terrestrial or cable ATSC environment from your configuration file, select the checked option in the Options menu. A warning message is displayed indicating that there are PSIP tables present in the configuration file. Select Yes to delete the tables from the configuration file and to remove the associated icons from the hierarchy (the PSIP table files remain unchanged on your disk). Select No to cancel the environment change.

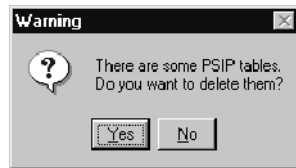

See *Adding and Editing PSIP Tables* beginning on page 3-62 for more information about PSIP table parameters and how to edit them.

Dynamic SI. When Dynamic SI is selected, the multiplexer dynamically manages the contents of the system date table (SDT) and event information table (EIT) according to the time and date table (TDT) time. All SDT running status fields are changed according to the program state (running/not running). The EIT is managed as follows:

- Present events are removed when necessary
- Following events become Present events
- Schedule events change to Following events when necessary

If Dynamic SI is selected and you attempt to generate a multiplex from a configuration file that does not contain a TDT, the warning message below appears.

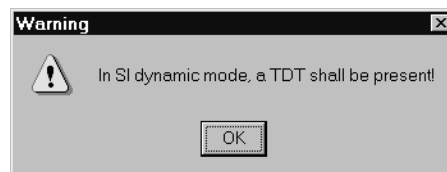

Select OK, add a TDT, and try to generate the multiplex again.

Directories. You can specify directories that the multiplexer displays when you open or associate various file types. Use the following procedure to set these directories:

1. Select **Directories** from the Options menu.

The Directories Selection dialog box is displayed. The recommended directories are shown in the following illustration.

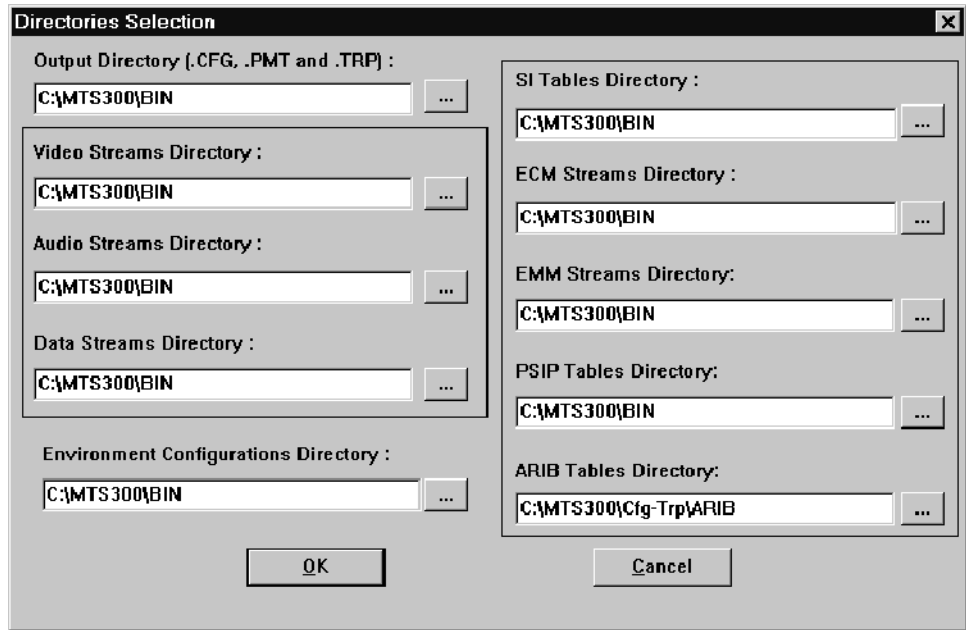

2. Change directories by entering the complete path in the appropriate text boxes.
3. Click **OK** to accept the displayed paths and close the dialog box, or click **Cancel** at any time to close the dialog box without making any changes.

Saving and Loading Multiplexer Environments

Use the Save Environment, Load Environment, and Default Environment Options menu selections to save and later restore multiplexer environments.

Save Environment. To save the current environment settings, use the following procedure:

1. Choose **Save Environment** from the Options menu.
2. Use standard Windows NT techniques to save the current environment settings using the dialog box shown below, and then click **OK** (or click **Cancel** to close the dialog box without saving the current environment).

By default, the file receives the extension *.mcf (multiplexer configuration file).

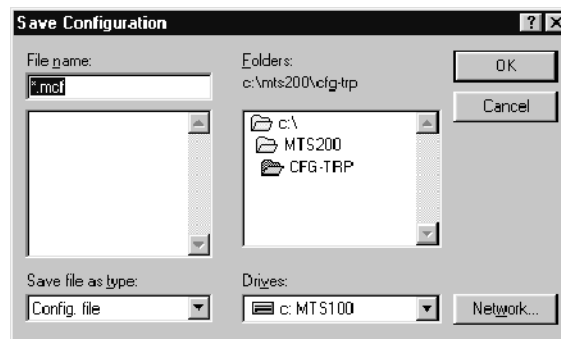

Load Environment. To load a saved environment (a *.mcf file), use the following procedure:

1. Choose **Load Environment** from the Options menu.

If you choose Load Environment when the DVB, ISDB-S/ARIB, or ATSC environment option is selected, a warning appears to remind you that the current environment may not be selected in another environment (shown here when the DVB environment is the current environment).

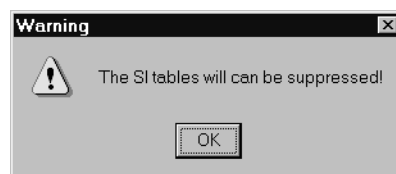

2. Click **OK** to acknowledge the warning and a Window Open dialog box appears.
3. Use standard Windows NT techniques to select the appropriate (*.mcf) file name, and then click **OK** to load the settings and dismiss the dialog box, or click **Cancel** to close the dialog box without making any changes.

Default Environment. Use the following procedure to load the default environment settings for the multiplexer:

1. Choose **Default Environment** from the Options menu.
2. In the resulting Message box, click **Yes** to confirm the command; click **No** to cancel it.

If the currently selected environment is DVB and/or ATSC, the following warning is displayed (shown here with DVB as the current environment).



3. Click **OK** to acknowledge the warning.

If SI or PSIP tables are selected in the current multiplex configuration, the following warning message appears (shown here with DVB as the current environment).

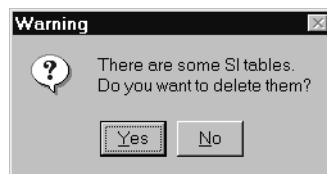

4. Click **Yes** to remove the tables from the current hierarchy; click **No** to restore all defaults but the DVB or PSIP environment option, which will remain selected.

Table 3-9 lists the default multiplexer options settings. During normal installations of MTS300 software, a directory structure is created, which includes directories for video, audio, and data files. The directories listed in Default setting column of Table 3-9 indicate the recommended directory configuration for the data types described in the Option column.

Table 3-9: Default multiplexer settings

Option	Default setting
DVB	Not selected
DVB-T Mega-frame	Not selected
ISDB-S/ARIB	Not selected
Terrestrial ATSC	Not selected
Cable ATSC	Not selected
Scrambling	Not selected
Dynamic SI	Not selected
Directories	
Output	c:\mts300\cfg-trp
Video Streams	c:\mts300\video
Audio Streams	c:\mts300\audio
Data Streams	c:\mts300\data
Environment Configurations	c:\mts300\cfg-trp
SI Tables	c:\mts300\cfg-trp
ECM Streams	c:\mts300\cfg-trp
EMM Streams	c:\mts300\cfg-trp
PSIP Streams	c:\mts300\cfg-trp

Creating and Editing a Configuration File

To create an MPEG-2, DVB, or ATSC transport stream with the multiplexer, you must first create a configuration file that describes the stream. A tutorial for creating an MPEG-2 configuration file and transport stream begins on page 2-7; a tutorial for creating a configuration file with DVB information continues on page 2-39. The process for creating a configuration file with ATSC information is essentially the same as the process for creating a DVB stream.

This section begins with basic techniques for creating configuration files (the first four sections), and then provides reference material for adding items to, and editing the parameters of, a configuration file:

- Creating or Opening a Configuration File (page 3-33)
- Environment Options (page 3-34)
- Adding and Editing Hierarchy Items (page 3-34)
- Deleting Hierarchy Items (page 3-36)
- Editing Multiplex Parameters (page 3-37)
- Editing the PSI Period (page 3-38)
- Editing the SI Period (page 3-39)
- Editing the PSIP Period (page 3-40)
- Editing the ARIB Period (page 3-40)
- Editing PAT Parameters (page 3-41)
- Editing the PMT (page 3-42)
- Editing the NIT (page 3-42)
- Adding Programs to the Multiplex (page 3-44)
- Editing Program Parameters (page 3-45)
- Adding Elementary Streams to a Program (page 3-46)
- Selecting a Video Stream (page 3-47)
- Selecting an Audio Stream (page 3-49)
- Selecting a Data Stream (page 3-51)
- Adding and Editing a Video Splice (page 3-52)
- Adding and Editing SI Tables (page 3-52)
- Adding and Editing DVB-T MIP Parameters (page 3-56)

- Adding and Editing PSIP Tables (page 3-62)
- Adding and Editing ARIB Tables (page 3-78)

Creating or Opening a Configuration File

Use the following procedures to create a new configuration file or to open an existing one:

1. To create a new configuration file, select **New** from the File menu or click the New button (the left-most command button on the toolbar). The New configuration file dialog box appears.

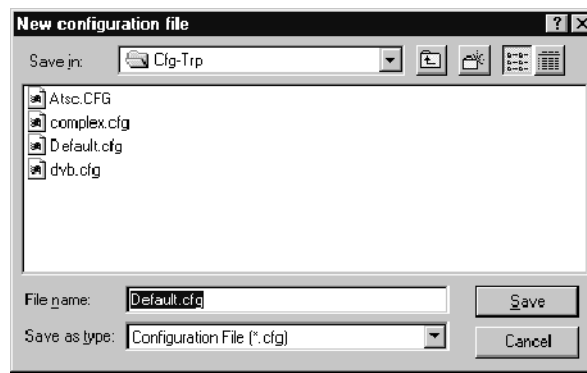

2. Enter an appropriate name in the File name text box and click **OK**; the *.cfg extension is added automatically. The default hierarchy appears in the Multiplex window.

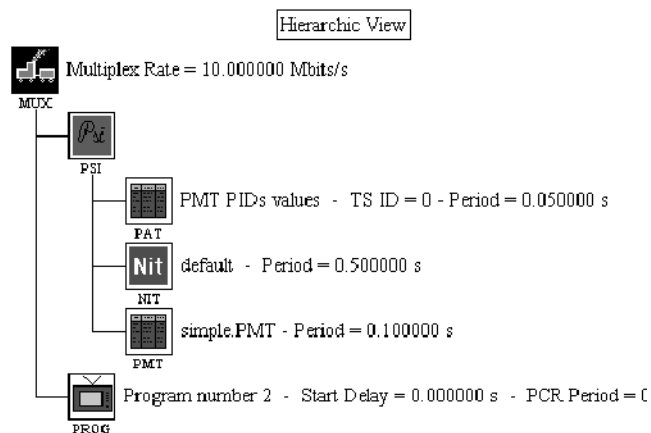

1. To open an existing file, select **Open** from the File menu or click the Open button. The Configuration file dialog box appears.

2. Enter or select the file name and click **OK**. The configuration file opens with the hierarchy in the Multiplex window.

Environment Options

The default environment for a new configuration file is MPEG-2. If you intend to create a DVB, ISDB-S/ARIB, or ATSC transport stream from a new configuration file, be sure that the relevant environment option is selected in the Options menu before adding or deleting hierarchy items. Refer to *Changing Environment Options*, on page 3-21, for more information.

Adding and Editing Hierarchy Items

Use the following procedure to add items to the configuration file hierarchy:

1. Select the appropriate hierarchy icon and use one of the following techniques:
 - Click the + (Add) button on the toolbar.
 - Choose **Add** from the Edit menu.
 - Press the INSERT key on your keyboard.

If there are multiple items that can be added to the item you have selected, a selection dialog box is displayed (the dialog box shown is the one displayed when you add elementary streams to a Program icon).









2. Select the item you want to add from the dialog box, and then click **OK** to accept the selection and return to the Hierarchic view.

You can select **Cancel** at any time to close the selection dialog boxes without adding items to the hierarchy.

An icon for the item you add appears subordinate to the icon you selected.

Table 3-10 on page 3-35 describes the use of the multiplexer Add command for each item in the Hierarchic view to which you can add items.

Table 3-10: Using the Add command

Item icon	Represents	Use the Add command to
 MUX	Multiplex	Add an empty program to the end of the hierarchy.
 PSI	PSI information	Add a TSMT file to the configuration. Available for all environment options. If you have Conditional Access (Option CA) installed on your system, you can also add a CAT to the configuration. See <i>Scrambling/Conditional Access</i> on page 3-89 for more information about adding items when Option CA is installed.
 SI	Service information	Add DVB files to the configuration file. Available only when the DVB environment option is selected.
 PSIP	PSIP information	Add ATSC PSIP files to the configuration. Available only when one of ATSC environment options are selected.
 ARIB	ARIB information	Add ISDB-S/ARIB files to the configuration. Available only when the ISDB-S/ARIB environment option is selected.
 PROG	Program	Add an elementary stream to the selected program.
 VIDEO	Video elementary stream	Splice another video stream to the existing stream. The multiplex rate of the added stream can be no higher than that of the existing stream. Available for all environment options.

NOTE. The Add command is not available when other icons are selected.

You can use the Add and Delete command buttons with the selected item if the + or – symbol on the button is highlighted in blue.



Add/Delete



Add only



Delete only



Neither

You can begin editing the contents or characteristics of most items by double-clicking on the icon. Table and stream file associations and other parameters are edited with the multiplexer. Table files themselves are edited using one of the table editors, which you can start from the multiplexer when necessary. Editing that can be done in the multiplexer is explained in this section; table editing using the table editors is discussed in *Using the DVB and PSIP Table Editors*, beginning on page 3-93.

Deleting Hierarchy Items

The Delete command on the Edit menu deletes the selected item and any items subordinate to it from the configuration file and removes the associated icons from the Hierarchic view. For example, if you delete a program, all the associated elementary streams are also deleted. The Delete command in the Edit menu is equivalent to the – (Delete) button on the toolbar.

You can delete only the following:

- Programs (check first if it has elementary streams)
- Elementary streams: Video, Audio, and Data
- PSI tables: TSDT, CAT, and EMM. The PSI icon itself cannot be deleted.
- SI tables: EIT, SDT, BAT, TDT, TOT, RST, and NIT (replaced with the default NIT). The SI icon itself cannot be deleted; it represents the DVB environment. If you want to change the multiplexer environment, refer to *Changing Environment Options*, on page 3-21.
- PSIP tables: MGT, VCT, SST, RRT, EIT, and ETT. The PSIP icon itself cannot be deleted; it represents the PSIP environment. If you want to change the multiplexer environment, refer to *Changing Environment Options*, on page 3-21.
- ARIB tables: DCT, DLT, BIT, SIT, DIT, and SDTT. The ARIB icon itself cannot be deleted; it represents the ISDB-S/ARIB environment. If you want to change the multiplexer environment, refer to *Changing Environment Options*, on page 3-21.

All multiplexer configuration files require a NIT file (this is a multiplexer requirement, not an MPEG or DVB requirement). If you delete a NIT icon that is associated with a NIT file other than the default, the icon remains in the hierarchy and becomes associated with the *Default.NIT* file.

If you choose to delete a program and it is not empty (it has elementary streams), a dialog box appears requesting confirmation before the multiplexer application will delete the program. Click Yes to delete the program and the associated elementary streams. Click No to close the warning box without making any changes.

When you delete a program, its PID is automatically removed from the PAT and the rate gauge is updated.

Editing Multiplex Parameters

Double-click the MUX icon to open the Multiplex Parameters dialog box shown below. Edit the multiplex parameters as required.

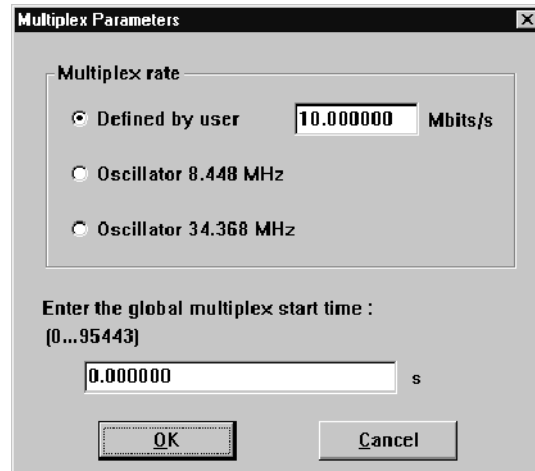

Select or enter the appropriate multiplex rate and enter the global multiplex start time, if appropriate. Click OK to accept the values and dismiss the dialog box.

The Multiplex Rate is the number shown at the top of the multiplexer rate gauge. This value defines the data rate for the generator. You can either define your own multiplex rate or use one of the predefined G703 frequencies: 8.448 MHz or 34.368 MHz. The default value is 10 Mbps.

NOTE. If you are creating a transport stream file for a G.703 port, you *MUST* select either the 8.448 or the 34.368 MHz option for the correct G.703 rate.

The global multiplex start time is the system clock time at the beginning of the transport stream. You can see the effect of changing the start time in the following Dynamic view illustration.

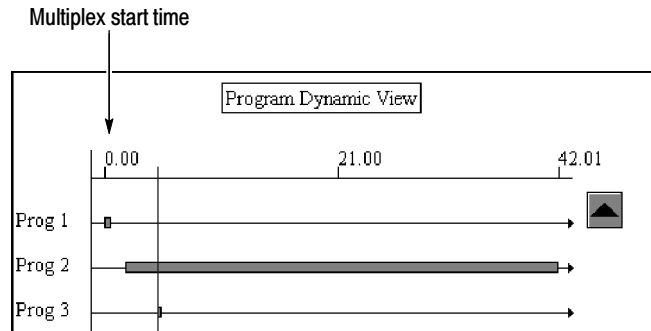

Editing the PSI Period

Use the following procedure to change the period for the PMT, PAT, and/or CAT (if Option CA is installed):

1. Double-click the **PSI** icon to open the PSI Period dialog box shown below (shown with Option CA installed).

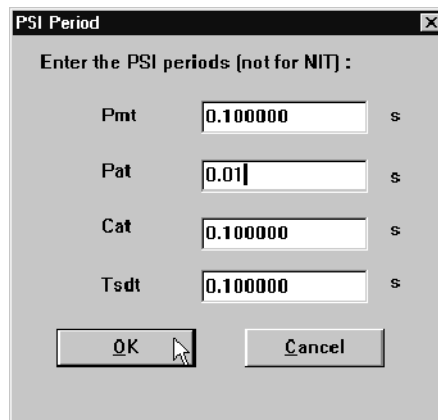

2. Enter the appropriate period for the PAT, PMT, TSDT, and CAT.
3. Click **OK** to accept the value(s) and close the dialog box, or click **Cancel** to close the dialog box without making any changes.

MPEG-2 requires a PSI period of 0.1 s (10 times per second) or less. However, you can set this value out of specification in order to thoroughly test your receiving system. Remember that if you make the period too small, you will have less of the available multiplex rate left in the transport stream for other, perhaps more important information.

Editing the SI Period

Use the following procedure to edit the period(s) for the DVB-SI tables for your configuration file:

1. Double-click the **SI** icon to open the DVB Files Selection dialog box shown in the following illustration. (DVB SI tables already included in the configuration file are indicated in the table file name field.)

The screenshot shows the 'DVB Files Selection' dialog box with the following fields and controls:

- NIT File:** C:\MTS300\Cfg-Trp\dvb.NIT (Browse...)
- NIT Period:** 0.500000 s (Edit)
- BAT File:** C:\MTS300\Cfg-Trp\dvb.BAT (Browse...)
- BAT Period:** 0.500000 s (Edit)
- SDT File:** C:\MTS300\Cfg-Trp\dvb.SDT (Browse...)
- SDT Period:** 0.500000 s (Edit)
- EIT File:** C:\MTS300\Cfg-Trp\dvb.EIT (Browse...)
- EIT Period:** 0.500000 s (Edit)
- TDT Starting Date:** 12/31/2000
- TDT Starting Time:** 01:00:00
- TDT Period:** 0.100 s
- TDT:** TDT
- RST File:** none (Browse...)
- Start Delay:** 0.0 s

Buttons: OK, Cancel

2. For each table type, change the period in the text boxes provided. In order to modify the TDT period, you must first select the TDT check box.
3. Click **OK** to accept any changes you have made and close the dialog box, or click **Cancel** at any time to close the dialog box without making any changes.

Editing the PSIP Period

Use the following procedure to change PSIP table periods:

1. Double-click the **PSIP** icon to open the PSIP Period dialog box shown below.

PSIP Period

Enter the PSIP period :

Mgt	<input type="text" value="0.100000"/>	s
Vct	<input type="text" value="0.300000"/>	s
Rtt	<input type="text" value="0.500000"/>	s
Stt	<input type="text" value="0.500000"/>	s

OK Cancel

2. For each table type, make the changes you want in the text boxes provided.
3. Click **OK** to accept the changes and close the dialog box. Select **Cancel** at any time to close the dialog box without making any changes to the PSIP period(s).

Editing the ARIB Period

Use the following procedure to change ARIB table periods:

1. Double-click the **ARIB** icon to open the PSIP Period dialog box shown below.

ARIB Period

Enter the ARIB periods :

Eit	<input type="text" value="0.500000"/>	s
Dct	<input type="text" value="0.500000"/>	s
Sdtt	<input type="text" value="0.1"/>	s
Sit	<input type="text" value="1"/>	s
Dit	<input type="text" value="0.100"/>	s

OK Cancel

2. For each table type, make the changes you want in the text boxes provided.
3. Click **OK** to accept the changes and close the dialog box. Select **Cancel** at any time to close the dialog box without making any changes to the ARIB table period(s).

Editing PAT Parameters

Use the following procedure to change the transport stream ID and the PID values for the NIT and program map tables:

1. Double-click the **PAT** icon to open the Program Association Table dialog box shown below.

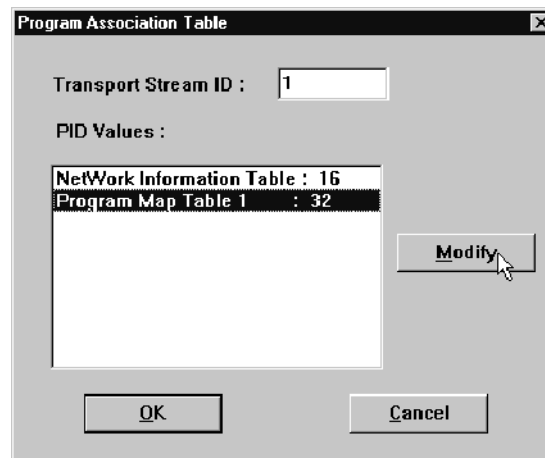

2. To change the transport stream ID, enter the new value in the text box.

NOTE. *The multiplexer automatically assigns PIDs when you add programs and tables. You need not change program PIDs unless the intended stream use requires it. Many table PIDs are specified in the appropriate MPEG, DVB, or ATSC standard. Do not change a table PID unless you know the consequences and have a good reason for doing so.*

3. To change the PID of a PMT section, highlight the entry in the PID Values dialog box and then click **Modify**.
4. Enter the desired PID number in the resulting PID Modification dialog box, and then click **OK** to close the dialog box.
5. Click **OK** to accept changes made to the transport stream ID and/or the PID values. Click **Cancel** at any time to close the dialog box without making any changes.

Editing the PMT

Double-click on the **PMT** icon to start the DVB Table Editor with the *.PMT file open for editing (the application creates the *.PMT file if it does not already exist).

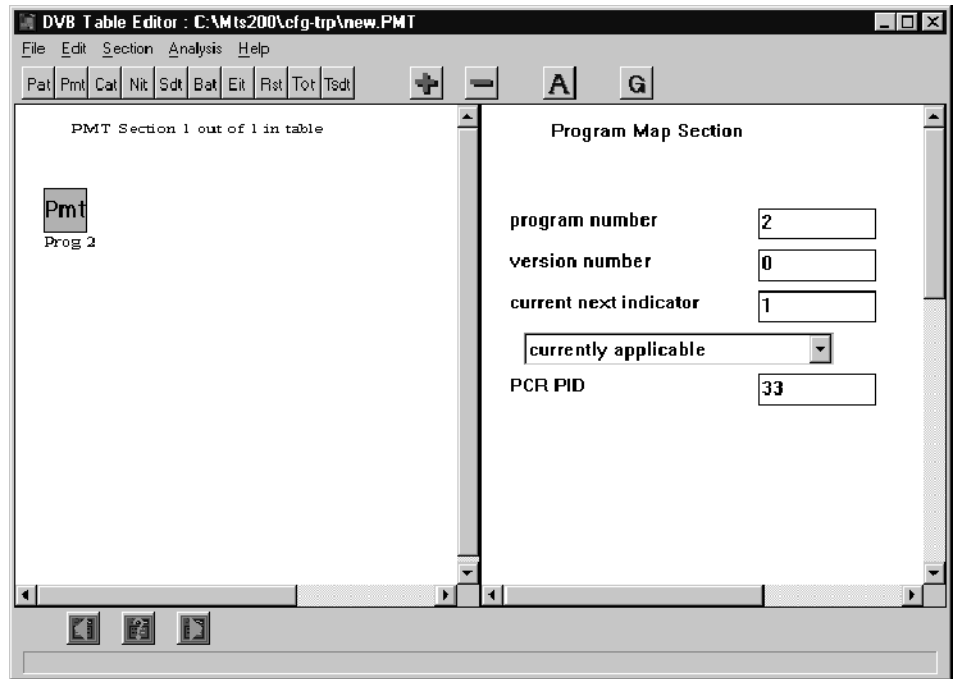

Refer to *Using the DVB and PSIP Table Editors*, beginning on page 3-93, for complete instructions on editing the PMT. The section describes how to edit the PMT from the PSIP table editor perspective, but the information applies to the DVB Table Editor as well.

Editing the NIT

To select and edit a network information table file, use the following procedure:

1. Double-click the **NIT** icon to open the NIT dialog box.

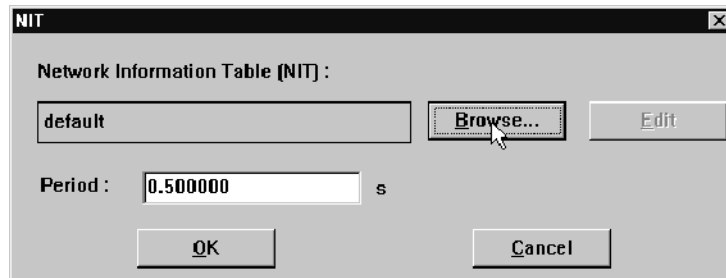

If you have not already associated a *.NIT file with the NIT icon, the table name field will contain only the word *default*. You must select a file before you can edit the Network Information Table.

2. Click **Browse** in the NIT dialog box, and the Selection SI File dialog box is displayed.

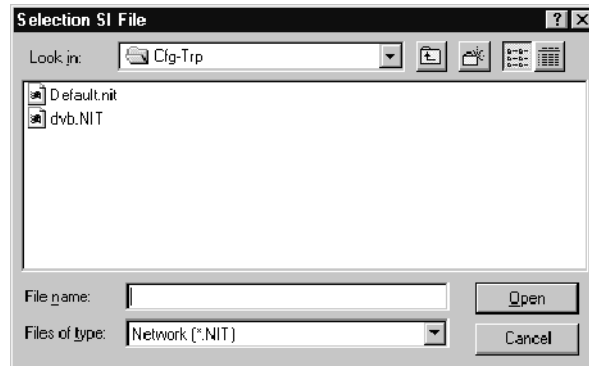

3. Select **DEFAULT.NIT** or another file to use as a template, and then click **OK**.

When you complete the file selection, the file selection dialog box closes and leaves the **NIT** dialog box open. The name of the opened file is in the table name field.

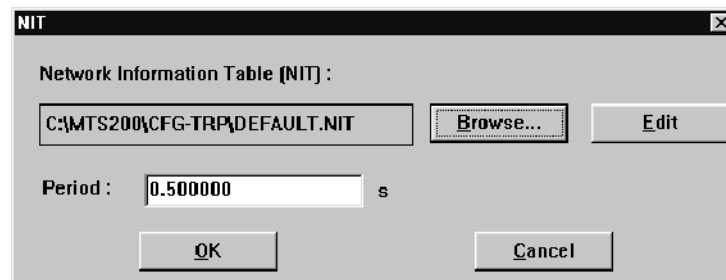

4. Click **Edit** to start the DVB Table Editor with the selected *.NIT file open for editing.
5. Using the table editor, save the table under a new, unique name (usually the name of the configuration file); the table automatically receives the *.NIT filename extension when you save it.
6. Edit the table as necessary. Refer to *Using the DVB and PSIP Table Editors*, beginning on page 3-93, for complete instructions on editing DVB table files.

7. Save the file again and exit the table editor.

After you exit the table editor, the NIT dialog box remains in front of the multiplexer application window with the original file name (usually DEFAULT.NIT) in the table name box.

8. Click **Browse** to open the Selection SI Tables dialog box again and select the newly edited and saved table.
9. If appropriate, change the period (the time between occurrences of the NIT in the transport stream) from within the NIT dialog box.
10. Click **OK** to accept the NIT file and its period setting and to close the dialog box, or click **Cancel** to close the dialog box without making any changes to the configuration file (the NIT file will maintain whatever changes you made to it from within the table editor).

The name of the table file and the period appear to the right of the NIT icon in the multiplexer Hierarchic view.

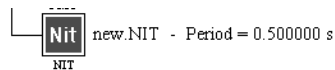

Adding Programs to the Multiplex.

To add a program to the hierarchy, select the **MUX** (multiplex) icon, and then click the **+** (Add) button (or press **INSERT** on the keyboard). A new program icon is added to the end of the configuration hierarchy. A transport stream can contain up to 20 programs.

Adding a program automatically adds a section to the program map table and updates the program allocation table to reference the PID of the new section. Once you have added a program, edit program parameters and add elementary streams, as necessary.

Editing Program Parameters

Use the following procedure to edit the program clock reference (PCR) period and/or the program start delay:

1. Double-click on the **Program** icon to open the Program Parameters dialog box.

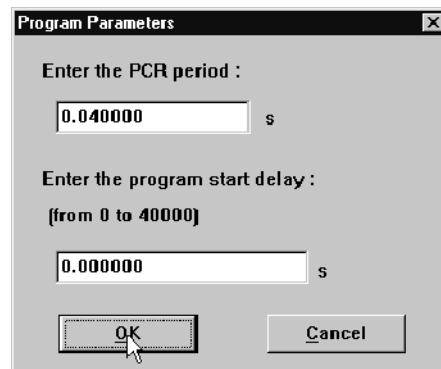

2. Change the PCR period as needed in the text box provided.

The PCR period determines the frequency of program clock references in the program stream. MPEG-2 requires at least 10 clock references per second, for a maximum of 0.1 seconds between PCR signals. If you enter a PCR period over 0.1 seconds, you will receive a warning when you close the Program Parameters dialog box.

NOTE. *The multiplexer encodes the PCR by default with the first elementary stream you add to the program. You can, however, change the PID of either PCR or elementary stream when you edit the PMT (see page 3-42 for instructions). If the PCR is not encoded with one of the elementary streams, it will be in its own packets.*

3. Change the program start delay as needed in the text box provided.

Program start delay determines the start time of the program relative to the beginning of the transport stream. Select the Dynamic view to see the effect of program start delay. (See *The Dynamic View* beginning on page 3-16 for more information about viewing the effects of changing the program start delay.)

Adding Elementary Streams to a Program

Adding an elementary stream to a program is a two-step process:

- Add a video, audio, data, or ECM (if Option CA is installed) item icon to the hierarchy (described in this section).
 - Associate a file (of the appropriate type) with the icon (described in the next three sections).
1. To add an icon to the program, select the **PROG** icon and click the **+** (Add) button (or press **INSERT** on the keyboard).

The Stream to add dialog box opens (shown here with Option CA installed).



2. Select the type of stream that you want to add and click **OK**, or click **Cancel** to close the dialog box without making any changes.

The selected icon appears in the hierarchy as a component of the program. Each new stream icon is added to the end of the program hierarchy. Elementary streams are not sorted by type.

You must associate a stream file with each new icon. Refer to *Selecting a Video Stream* (page 3-47), *Selecting an Audio Stream* (page 3-49), *Selecting a Data Stream* (page 3-51) or *Creating a Stream with Scrambled Components* (page 3-90).



CAUTION. Although MPEG-2 transport streams allow elementary streams with encoding changes between field and frame, the multiplexer does not support such changes.

Selecting a Video Stream

Use the following procedure to associate a video elementary stream file with a Video icon in the the program hierarchy:

1. Double-click on the **Video** icon to open the Video Stream dialog box.

Using this dialog box, you can identify a video stream file to associate with the program icon. You can also set several parameters that determine how the multiplexer encodes the stream.

The screenshot shows the 'Video Stream' dialog box with the following parameters:

Video File :	<input type="button" value="Browse..."/>		
Horizontal Size :	0	Picture Rate :	0.0000
Vertical Size :	0	VBV Buffer Size :	0
MPEG :	0	Profile :	-
		Level :	-
Elementary Stream Running Time :	0.000 s		
Elementary Stream Rate :	<input type="text" value="0.000000"/>	Mbits/s	
PES Packet Size :	<input type="text" value="2048"/>	Bytes	<input type="checkbox"/> Sequence Header
Elementary Stream Initial Delay :	<input type="text" value="0.000000"/>	s	<input type="checkbox"/> Scrambling
Offset DTS :	<input type="text" value="0.000000"/>	s	
<input type="button" value="OK"/>		<input type="button" value="Cancel"/>	

2. Click **Browse** to open the Video Stream Selection box.
3. Use standard Window NT techniques to find and select the video elementary stream file you want to include in the configuration file. You can select a file with any file extension, but the multiplexer application will not accept the file unless it has the correct video header information.
4. Click **OK** to return to the Video Stream dialog box.

The multiplexer extracts information from the header of the elementary stream file and displays the extracted values in the Video Stream dialog box. The parameters you can edit are described in the following list.

- The Elementary Stream Rate is the rate at which the elementary stream is to be multiplexed into the transport stream, after compression. The default value is the rate specified in the elementary stream header. This is the recommended value. You can change the rate to meet your specific requirements, as long as you do not intend to decode the transport stream in real time. A rate that is too slow will not give the decoder all the information required to decode in real time.
- The PES Packet Size can range from 100 to 64000 bytes. The default value for MPEG-2 and DVB is 2048 bytes; if you have one of the ATSC environment options selected, the default is zero. If you specify a packet size of 0, the multiplexer will put the complete video picture in one PES packet.
- The Elementary Stream Initial Delay determines when the elementary stream begins appearing in the transport stream. The delay is relative to the start of the program, which can have its own delay relative to the start of the transport stream (refer to *Editing Program Parameters*, on page 3-45, for more information). Delaying the start of the elementary stream extends program length by an equal amount of time but does not reduce the fraction of multiplex rate used during the delay.

NOTE. *The multiplex rate is not reduced during an elementary stream initial delay. Null packets fill in to replace elementary stream packets in the time between the start of the program and the start of the elementary stream.*

- Offset DTS is the time interval between the DTS (decode time stamp) and the arrival time of the access unit.
 - Sequence Header, when selected, causes the multiplexer to ignore any video stream data before the first sequence header. If you leave Sequence Header unchecked, the multiplexer inserts the entire video stream into the multiplex.
 - Scrambling, when selected, introduces encryption provided by Option CA, if installed. See *Creating a Stream with Scrambled Components* beginning on page 3-90 for additional information about scrambling elementary streams.
5. After you select the video stream file and set the stream parameters, click **OK** to confirm the choices and close the dialog box. Information about the selected file appears to the right of the video icon as shown below.

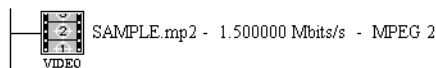

Selecting an Audio Stream

Use the following procedure to associate an audio elementary stream file with an Audio icon in the the program hierarchy:

1. Double-click on the **Audio** icon to open the Audio Stream dialog box.

Using this dialog box, you can identify an audio stream file to associate with the program icon. You can also set several parameters that determine how the multiplexer encodes the stream.

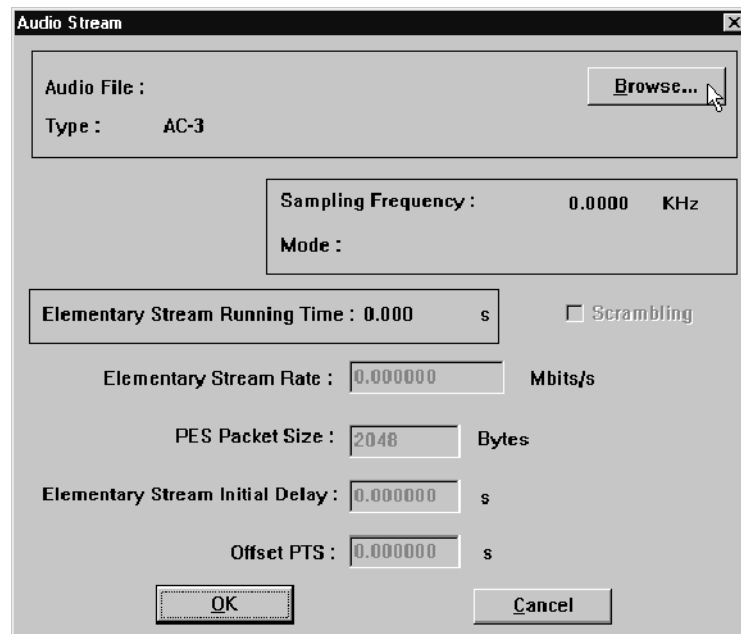

2. Click **Browse** to open the Audio Stream Selection box.
3. Use standard Window NT techniques to find and select the elementary stream file you want to include in the configuration file. You can select a file with any file extension, but the multiplexer application will not accept the file unless it has the correct header information.
4. Click **OK** to return to Audio Stream dialog box.

The multiplexer extracts information from the header of the elementary stream, including the audio file type (MPEG-2, AC-3, or AAC), and displays the extracted values in the Audio Stream dialog box. The parameters you can edit are described in the following list.

- The Elementary Stream Rate is the rate at which the elementary stream is to be multiplexed into the transport stream. The default value is the rate specified in the elementary stream header. This is the recommended value. You can change the rate to meet your specific requirements as long as you do not intend to decode the transport stream in real time. A rate that is too slow will not give the decoder all the information required to decode in real time.
 - The PES Packet Size can range from 100 to 64000 bytes.
 - The Elementary Stream Initial Delay determines when the elementary stream begins appearing in the transport stream. The delay is relative to the start of the program, which can have its own delay relative to the start of the transport stream (refer to *Editing Program Parameters*, on page 3-45, for more information). Delaying the start of the elementary stream extends program length by an equal amount of time, but does not reduce the fraction of multiplex rate used during the delay.
 - Offset PTS is the interval between the PTS (presentation time stamp) and arrival time.
 - Scrambling, when selected, introduces encryption provided by Option CA, if installed. See *Creating a Stream with Scrambled Components* beginning on page 3-90 for additional information about scrambling elementary streams.
5. After you select the audio stream file and set the stream parameters, click **OK** to confirm the choices and close the dialog box. Information about the selected file appears to the right of the audio icon as shown below.

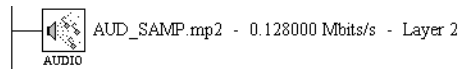

The Audio icon indicates whether the file chosen is an MPEG encoded audio stream, an AC-3 stream, or an AAC audio stream.

Selecting a Data Stream

Use the following procedure to associate an audio elementary stream file with an Audio icon in the the program hierarchy:

1. Double-click on the **Data** icon to open the Data Stream dialog box.

Using the Data Stream dialog box, you can identify a data stream file to associate with the program icon. You can also set parameters that determine how the multiplexer encodes the stream.

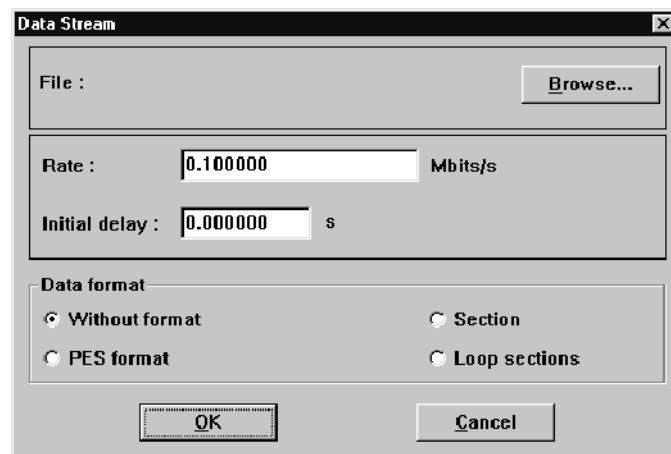

2. Click **Browse** to open the Data Stream Selection box.
3. Use standard Window NT techniques to find and select the file you want to include in the configuration file.
4. Click **OK** to return to Data Stream dialog box.

You can edit the following parameters:

- Rate determines how quickly the data is multiplexed into the transport stream. The default value is 0.1 Mbps.
- The Initial Delay determines when the data begins appearing in the transport stream. The delay is relative to the start of the program and works in the same way as the initial delays for the video and audio elementary streams.
- Use the Data Format selections to specify the transport stream data format:
 - Select **Without format** if the data is not in PES or section format.
 - Select **PES format** if the data is in PES format.
 - Select **Section** if the data is in section format.
 - Select **Loop sections** if the data is in section format and the sections should be looped.

5. After you select the data stream file and set the stream parameters, click **OK** to confirm the choices and close the dialog box. Information about the selected file appears to the right of the data icon.

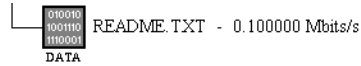

Adding and Editing a Video Splice

To add a video splice to the multiplex, use the following technique:

- Select the video icon for which you want to create the splice, and then click the **+** button on the toolbar.

The splice icon is added to the hierarchy immediately below the video icon you selected. Only one splice can be added to a given video icon.

The procedure for selecting and editing video splice parameters is identical to the procedure used for selecting and editing a video elementary stream (see *Selecting a Video Stream* on page 3-47 for more information).

Adding and Editing SI Tables

The SI icon is present in the multiplexer hierarchy when DVB is selected in the Options menu.

To add and edit SI tables one at a time, use the following procedure:

1. Select the **SI** icon and click the **+** (Add) button (or press the **INSERT** key on your keyboard). The Selection of a SI Table dialog box is displayed.

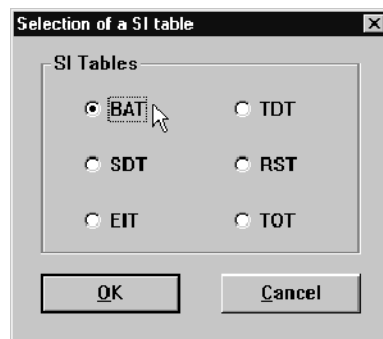

2. Select the SI table type you want to add, and then select **OK**, or select **Cancel** to return to the Hierarchic view with making changes to the configuration file.

If you select OK, a dialog box similar to the one shown in the following illustration is displayed. This dialog box allows you to associate a specific DVB SI table file with your configuration file (see step 3), to set the period for the selected table (see step 5), and to start the DVB Table Editor with the selected table file displayed (see step 6).

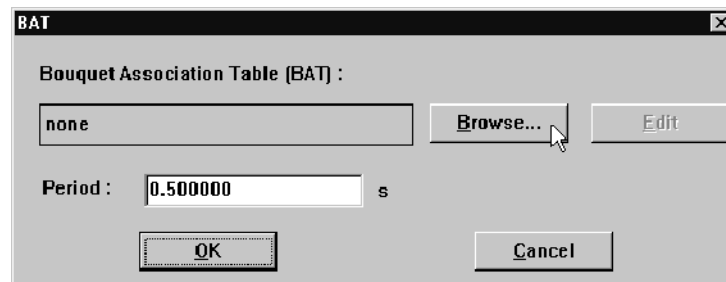

You can click **Cancel** any time this dialog box is displayed to close the dialog box without adding items to the hierarchy or changing the configuration file.

3. To associate a DVB SI file with your configuration file, click **Browse**.
4. Navigate to and select the template file you want using the displayed dialog box, and then select **OK**. (The template files are named *Default.xxx*.) You can select only files of the type you are trying to add to the hierarchy.

NOTE. During normal installation of the multiplexer, various table template files are installed in the *MTS300\CFG-TRP* directory. These files are provided so that you can start the table editor from the multiplexer. (You need to have a minimally valid file with which to start the table editor from within the multiplexer.)

5. To change the period of the selected table, edit the Period text box.
6. To edit the DVB table file selected in the file name field, click **Edit**. The DVB table editor will start with the selected table file displayed. If you open a template file, be sure to save it in the table editor using a different file name.

Refer to *Using the DVB and PSIP Table Editors*, beginning on page 3-93, for complete instructions on editing SI tables. The section describes how to edit tables and table elements using the PSIP table editor for the examples, but the information applies to the DVB table editor as well.

NOTE. Be sure that you exit the table editor before you continue to use the multiplexer.

7. After you edit and save the table, exit the table editor; you are returned to the table dialog box.
8. Click **Browse** and select the new table file you just created.
9. After you have made all the changes you want using the table dialog box shown in the previous illustration, click **OK** to accept the changes and close the dialog box, or click **Cancel** to close the dialog box without making any changes.

An icon for the table type is added to the Hierarchic view, and the configuration file is updated with the changes you have made.

Time and Date Table. Time and Date Table (TDT) parameters are used to specify the current time and date and start time of the transport stream; the TDT is managed by the multiplexer and no files are associated to the TDT icon in the SI hierarchy.

1. To include a TDT in a configuration file, select the SI icon and click the + (Add) button.
2. Click **TDT** in the Selection of a SI Table dialog box, and then click **OK**. The Time and Date Table dialog box is displayed with the start date and time and default period text boxes updated. You can edit these fields as necessary.



3. Click **OK** to accept the values in the text boxes, close the dialog box, and add a TDT icon to the SI hierarchy.

Once added to the hierarchy, you can display this dialog box to edit the TDT values by double-clicking the TDT icon.

Adding Multiple SI Tables. You can also add and edit multiple SI tables at once using the following procedure:

1. Double-click the **SI** icon to open the **DVB File Selection** dialog box. Table files that are already associated to the configuration file are indicated in the table file name fields, otherwise, *default* or *none* is indicated in the name field.

The screenshot shows the "DVB Files Selection" dialog box. It has a title bar with a close button. The dialog is organized into several sections, each for a different table type. Each section contains a text field for the file name, a "Browse..." button, and a numeric field for the period with an "Edit" button. The "NIT File" field is highlighted with a red arrow and labeled "Table file name field". The "NIT Period" is set to 0.500000 s. The "BAT File" is set to "none", "BAT Period" is 0.500000 s. The "SDT File" is set to "none", "SDT Period" is 0.500000 s. The "EIT File" is set to "none", "EIT Period" is 0.500000 s. The "TDT Starting Date" is 00/00/0000, "TDT Starting Time" is 00:00:00, "TDT Period" is 20.0 s, and there is an unchecked checkbox for "TDT". The "RST File" is set to "none", and "Start Delay" is 0.0 s. On the right side, there are "OK" and "Cancel" buttons.

2. Click **Browse** to select a table template file for one or more table types.
3. Click **Edit** next to the table file you want to modify. The DVB Table Editor will open with the selected DVB SI table displayed.

NOTE. If the table file you are editing with the table editor is a template file, be sure to save the table file under a new name (usually the name of the configuration file).

4. After you edit and save the table, exit the table editor; you are returned to the table dialog box.
5. Click **Browse** and select the new table file you just created.

6. Change the table period if necessary. You may wish to set the period much higher than the standard 0.5 seconds to create a transport stream that thoroughly exercises the MPEG-2 receiving equipment.
7. Click **OK** to accept your changes and close the DVB Files Selection dialog box, or click **Cancel** to close the dialog box without making any changes.

A tutorial for creating a configuration file with DVB information begins on page 2-39. The tutorial contains detailed instructions for adding SI table files. For more complete information about editing table files, refer to *Using the DVB and PSIP Table Editors*, which begins on page 3-93.

After you add a table, you can double-click the table icon to open a table dialog box and select a new table file, edit the table, or set the table period.

Adding and Editing DVB-T MIP Parameters

The MIP (Mega-frame Initialization Packet) icon is present in the multiplexer hierarchy only when the DVB-T Mega-frame option is selected in the Options menu (appears with a check mark next to it).

NOTE. *The DVB-T Mega-frame option can be selected with or without the DVB environment option selected. However, the DVB-T Mega-frame option does not add DVB tables to the configuration file.*

The MIP identifies the start of the next DVB-T mega-frame, and it provides mega-frame synchronization information for terrestrial single frequency networks (SFN). The MIP also allows you to identify various transmission parameters for the mega-frame, and allows you to specify parameters for unique transmitters in a network.

To insert a Mega-frame Initialization Packet (MIP) into the hierarchy and specify MIP parameters, use the procedures provided in this section.

NOTE. When you add a MIP to the configuration file and start to associate elementary stream files to the program icons, you may see a *Multiplex Overflow* warning. If so, change one or more of the following multiplex parameters:

- The constellation type (see Table 3-11 beginning on page 3-58)
- The code rate (see Table 3-11 beginning on page 3-58)
- The guard interval (see Table 3-11 beginning on page 3-58)
- The target multiplex rate (see Editing Multiplex Parameters beginning on page 3-37)
- The start time offset of one or more programs (see Editing Program Parameters beginning on page 3-45)

1. To add a MIP icon to the Hierarchic view, select **DVB-T Mega-frame** from the Options menu.

The DVB-T Mega-frame option will now appear with a check next to it in the Options menu, and the MIP icon is inserted below the SI icon and any DVB-SI tables present in the hierarchy.

2. To edit MIP parameters, double-click the MIP icon using the MIP Parameters dialog box shown in the following illustration.

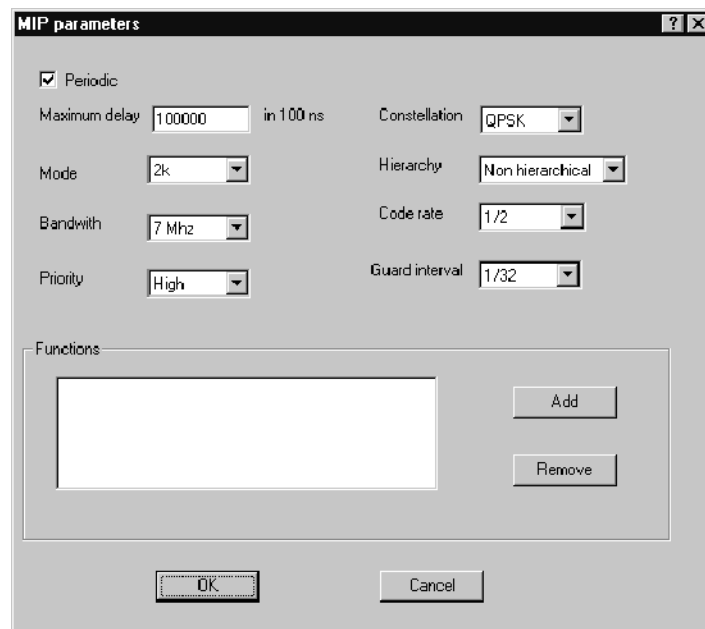

Press **Cancel** at any time to close the dialog box without making any changes to the MIP.

The values that are displayed in the MIP Parameters dialog box are different for the following two scenarios:

- Default.NIT is referenced in the configuration file, or the referenced NIT does not include a terrestrial delivery descriptor.
- The referenced NIT includes a terrestrial delivery descriptor.

Table 3-11 indicates the default values for the MIP parameters and the information that is extracted from the NIT for these two scenarios.

Table 3-11: MIP parameters

Parameter	Terrestrial delivery descriptor not present in the NIT	Terrestrial delivery descriptor present in the NIT	Description of parameter (range of accepted values)
Periodic	Selected	Selected	If selected, the MIP is inserted into the transport stream periodically, and the value of the MIP pointer is not time varying.
Maximum delay	100000 (in 100 ns)	100000 (in 100 ns)	Specifies the maximum delay beyond which the mega-frame is considered invalid. (0 to 999999 (in 100 ns))
Mode	2 k	Extracted from NIT	Transmission mode of the mega-frame identified by the MIP. (2 k or 8 k)
Bandwidth	7 MHz	Extracted from NIT	Specifies the channel spacing for re-multiplexed bitstream. (7 or 8 MHz)
Priority	High	High	Indicates whether the associated simulcast bitstream is a low bitrate (high priority) or high bitrate (low priority) stream.
Constellation	QPSK	Extracted from NIT	Identifies the type of modulation used by the associated bitstream. (QPSK or 16/64 QAM)
Hierarchy	Non hierarchical	Extracted from NIT	Specifies the transmission mode use by the associated bitstream. (Non hierarchical; or α (constellation ratio) = 1, 2, or 4)

Table 3- 11: MIP parameters (Cont.)

Parameter	Terrestrial delivery descriptor not present in the NIT	Terrestrial delivery descriptor present in the NIT	Description of parameter (range of accepted values)
Code rate	1/2	Extracted from NIT	Specifies the code rate used for the transmission environment of the associated bitstream. (1/2, 2/3, 3/4, 5/6, or 7/8)
Guard interval	1/32	Extracted from NIT	Specifies the guard interval of the associated bitstream as a proportion of the useful interval. (1/4, 1/8, 1/16, 1/32)
Functions	No functions	No functions	See Table 3-12.

3. Make the selections and changes appropriate for your environment.
4. To add functions to the MIP (such as power and frequency offset) for a specific transmitter in the network, or to all transmitters in a network, click **Add** in the Functions group at the bottom of the dialog box. The Add Functions dialog box is displayed.

The screenshot shows a dialog box titled "Add function" with a standard Windows-style title bar (minimize, maximize, close buttons). The dialog contains the following elements:

- Tx identifier:** A text input field containing the number "1".
- Time Offset:** A checkbox that is unchecked, followed by a text input field and the label "in units of 100 ns".
- Frequency offset:** A checkbox that is unchecked, followed by a text input field and the label "Hz".
- Power:** A checkbox that is unchecked, followed by a text input field and the label "dBm".
- Private Data:** A checkbox that is unchecked, followed by a text input field and the label "In hexa".

At the bottom of the dialog are two buttons: "OK" and "Cancel".

5. To change a value for one of the defined MIP functions, check the option box next to the function name, and change the value in the text box as appropriate.

Descriptions of the MIP functions and the range of possible values for the functions are provided in Table 3-12.

Table 3-12: MIP functions

Function	Range of accepted values	Description of function
Tx identifier	0 to 65535	A 16 bit identifier for a specific transmitter. The functions added are applied to the transmitter specified in this text box. The value 0 (0x000) is reserved as the identifier for all transmitters on the network.
Time offset	– 32768 to 32767 (in 100 ns increments)	The transmitted time offset of the mega-frame.
Frequency offset	– 8388608 to 8388607 (Hz)	The frequency offset relative to the center frequency of the RF channel in use.
Power	0 to 65535 (dBm)	The power of the transmitter is defined as the effective radiated power (ERP).
Private data	User defined hexadecimal values.	You can use this function to send private data to the specified transmitter in the MIP.

NOTE. You can add as many functions as you want provided the size of the MIP does not exceed 188 bytes.

- To accept the changes you have made in the Add Functions dialog box and close it, select **OK**. The functions you have added appear in the Functions selection box. Click **Cancel** at any time to close the dialog box without adding functions to the MIP.

7. To remove a function, highlight it as indicated in the following illustration, and then click **Remove**.

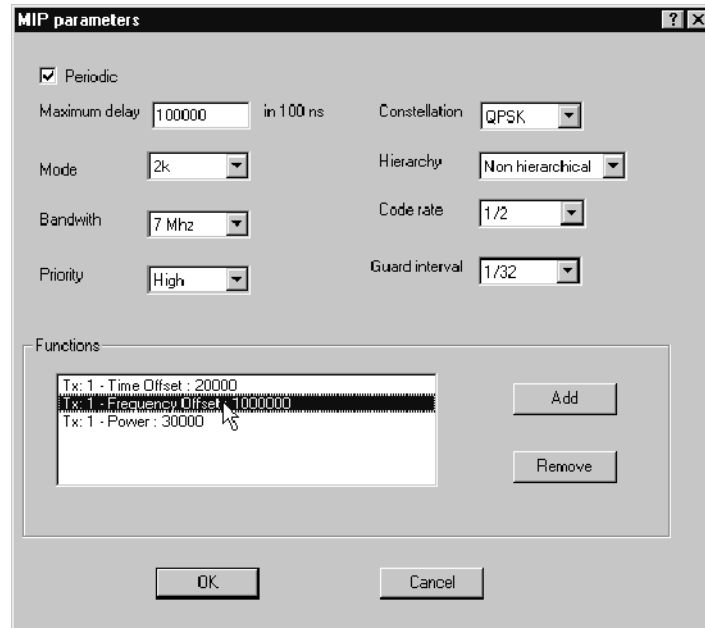

8. To accept your changes and return to the Hierarchic view, click **OK**. Click **Cancel** at any time to close the MIP Parameters dialog box without making changes to the MIP parameters.

To remove a MIP from the configuration file, select **DVB-T Mega-frame** from the Options menu. This will remove the check mark next to the menu item, remove the icon from the hierarchy, and the MIP will not be generated when you create a multiplex from the configuration file.

Adding and Editing PSIP Tables

The PSIP icon is present in the multiplexer hierarchy when either the Terrestrial ATSC or Cable ATSC option is selected in the Options menu. To add PSIP information to your configuration file, select the appropriate ATSC menu item from the Options menu (Terrestrial ATSC or Cable ATSC).

The following illustration shows the default Hierarchic view when the Terrestrial ATSC option is selected.

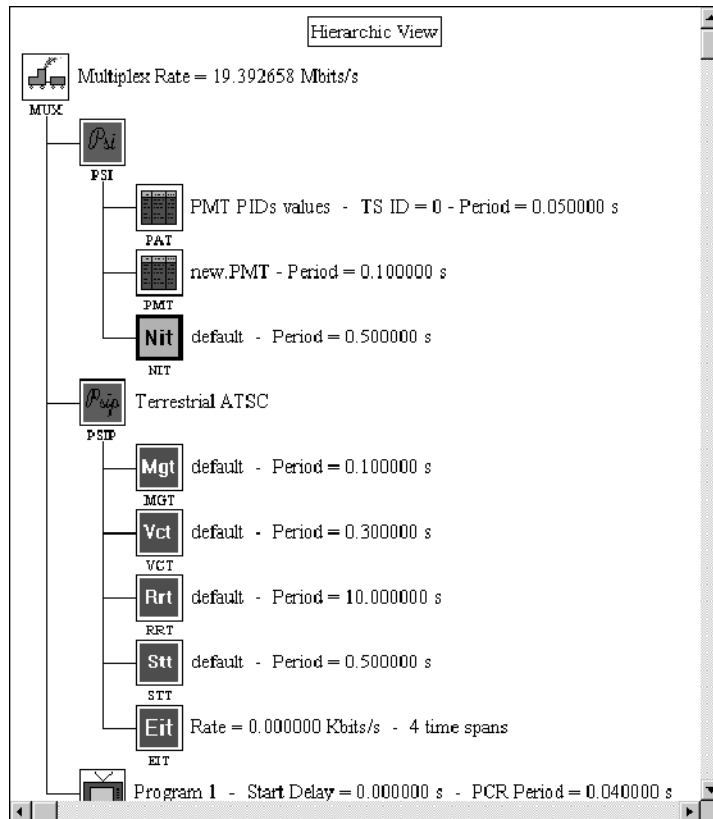

The following list describes the PSIP icons added to the hierarchy when you select an ATSC environment option:

- **MGT (Master Guide Table).** This icon is added to the hierarchy when you select either terrestrial or cable environment options. The MGT defines the types of PSIP tables included in the multiplex, and the PIDs for each table, except for the system time table, which is not managed by the MGT.
- **VCT (Virtual Channel Table).** This icon is added to the hierarchy when you select either terrestrial or cable environment options. The VCT defines the programs included in the multiplex. Depending on whether you selected the terrestrial or cable environment option, you need to associate the correct table type to the VCT icon: Terrestrial Virtual Channel Table (TVCT), or Cable Virtual Channel Table (CVCT).
- **RRT (Rating Region Table).** This icon is added to the hierarchy when you select either terrestrial or cable environment options. The RRT defines the parental guidelines system for different regions. The RRT is referenced by content advisory descriptors carried in the transport stream.
- **STT (System Time Table).** This icon is added to the hierarchy when you select either terrestrial or cable environment options. The SST provides current time and date information for the multiplex.
- **EIT (Event Information Table).** This icon is added to the hierarchy only when you select the terrestrial environment option, although, you can add it to the cable environment. The EIT contains information about events on the defined virtual channels carried in the multiplex. An event can be a program, data broadcasting session, or other information. The descriptive information carried in the EIT can include event names, start times, and durations. The EIT can also reference programs carried by other multiplexes or networks.
- **ETT (Extended Text Table).** The ETT is an optional table for both terrestrial and cable ATSC environments, and the ETT icon is not initially added to the multiplex hierarchy when you select an ATSC environment option. The ETT contains extended text message streams (ETMs) and is used to provide detailed descriptions of virtual channels and events.

NOTE. *During normal installation of the multiplexer, various table template files are installed in the MTS300\CFG-TRP directory. These files are provided so that you can start the PSIP table editor from the multiplexer. (You need to have a minimally valid file with which to start the table editor from within the multiplexer.)*

To add PSIP table icons to the hierarchy and edit certain configuration file parameters use the following procedure:

1. Select the **PSIP** icon, and then select **+** (the Add button). The following dialog box is displayed.



2. Select the appropriate PSIP table option, and then click **OK**, or click **Cancel** to close the dialog box without making any changes to the hierarchy.

After you select OK, a dialog box similar to the one shown in the following illustration is displayed. This dialog box allows you to associate a specific PSIP table file with your configuration file (see step 3), to start the PSIP table editor with the selected file displayed (see step 5), and to set the period for the selected PSIP table (see step 8).

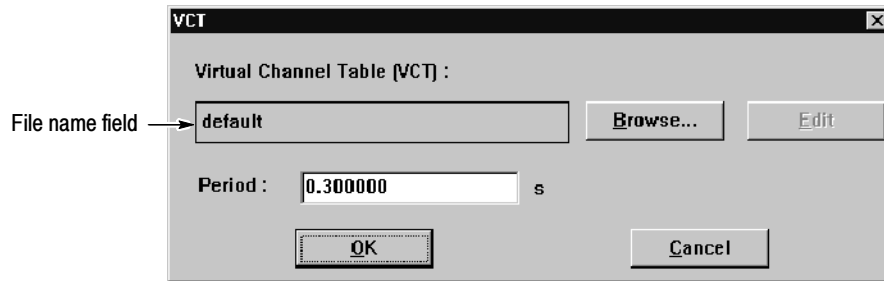

You can click **Cancel** any time this dialog box is displayed to close the dialog box without adding items to the hierarchy or changing the configuration file.

If you are working with a new configuration file, the table file name in the file name field is *default*, or *none*. To associate a PSIP file with a table icon in the Hierarchic view, continue with the procedure:

3. From the table dialog box, click **Browse**.
4. Navigate to and select the appropriate table template file (for instance *Atsc.Vct* for a virtual channel table file), and then select **OK**. You can select only files of the type you are trying to add to the hierarchy.

5. To edit the PSIP table file indicated in the file name field, click **Edit**. The PSIP Table Editor will start with the selected table file displayed.
6. From the table editor, save the table file under a new name (usually the name of the configuration file).

NOTE. Be sure that you exit the PSIP Table Editor before you continue to use the Multiplexer.

7. Click **Browse** and select the table file you just created.

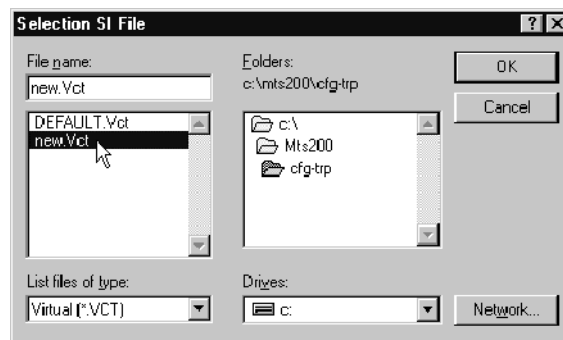

8. To change the period of the selected table, edit the Period text box.
9. After you have made all the changes you want using the dialog box shown in the previous illustration, click **OK**.

An icon for the table type is added to the Hierarchic view, and the configuration file is updated with the changes you have made.

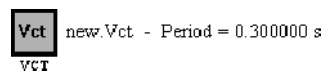

See *Using the DVB and PSIP Table Editors* beginning on page 3-93 for more information about creating and editing PSIP tables. See *Associating EIT Table Files* on page 3-68, and *Adding ETT Instances* on page 3-76, for the procedures to add and edit PSIP EIT and ETT tables using the multiplexer.

Setting PSIP Table Periods. To set the periods for the MGT, VCT, RRT, and STT, use the following procedure:

1. Double-click the **PSIP** icon in the Hierarchic View.

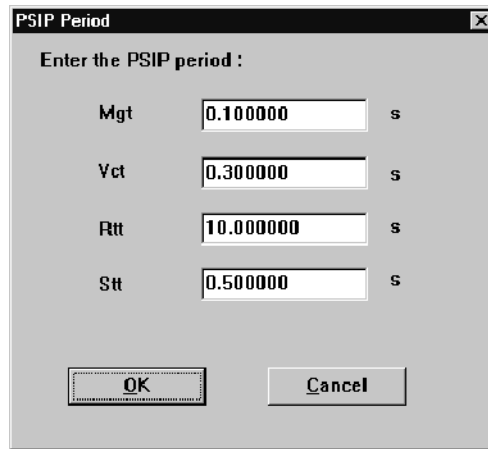

The image shows a dialog box titled "PSIP Period" with a close button (X) in the top right corner. The dialog contains the text "Enter the PSIP period :". Below this text are four rows, each with a label, a text input field, and a unit "s". The labels and their corresponding values are: Mgt (0.100000), Vct (0.300000), Rtt (10.000000), and Stt (0.500000). At the bottom of the dialog are two buttons: "OK" and "Cancel".

2. Change the periods as appropriate and then click **OK** to accept your changes and close the dialog box, or click **Cancel** at any time to close the dialog box without making any changes to the PSIP periods.

PSIP EIT Tables. In the ATSC environment, Event Information Tables (EIT) are used to describe events, such as programs or data broadcast sessions, for the virtual channels described in the Virtual Channel Table (VCT).

In order to create a valid ATSC transport stream, you need to multiplex at least four EIT files along with the other program data. Each EIT file specifies events that occur during sequential, three-hour periods (EIT periods are called time spans and are designated as EIT- k , where k is a positive integer between 0 and 127). The four required EIT time spans are EIT-0, EIT-1, EIT-2, and EIT-3.

Channels, events, and extended text messages (ETM) are managed using the following VCT, EIT, and ETT elements:

- Source IDs, which are specified in the channel element of the VCT and in the EIT.
- Event IDs, which are specified in the event element of the EIT.
- ETM IDs, which are specified in the ETT.

See *Using the PSIP Table Editor Global View Window* beginning on page 3-136 for more information about how PSIP tables are managed.

EIT Dialog Box. When you select an ATSC environment, an EIT icon is added to the PSIP hierarchy. (See the illustration on page 3-62.)

Double-click the EIT icon in the PSIP hierarchy to display the EIT dialog box.

NOTE. *Extended Text Tables (ETT) are optional, and an ETT icon is not added to the PSIP hierarchy when an ATSC environment is selected. You can use the procedures described in this section to associate, add, edit, and delete ETT instances after the ETT icon has been added to the PSIP hierarchy. See Adding ETT Instances beginning on page 3-76 for more information about adding the ETT icon to the configuration file.*

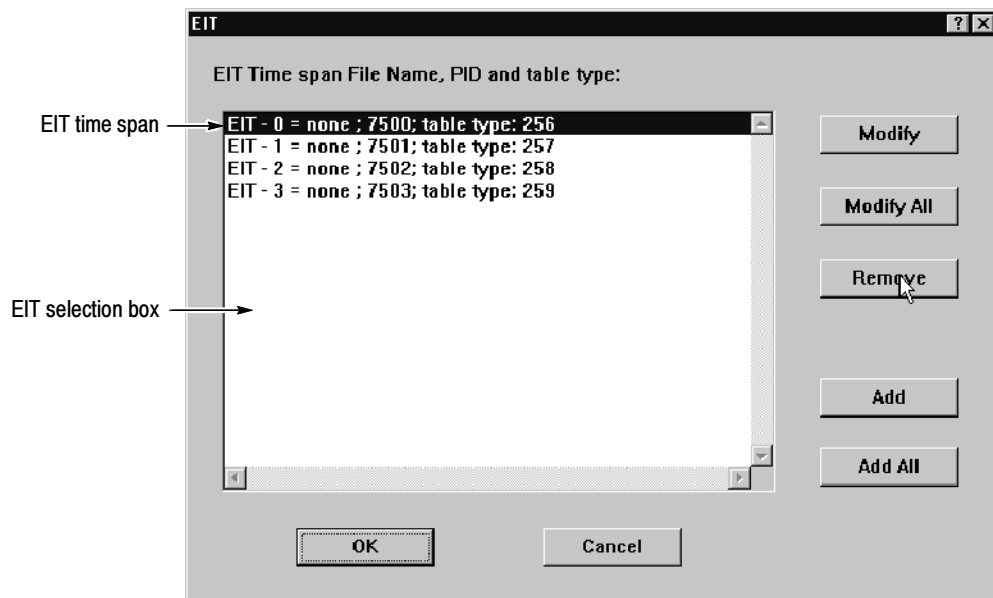

The EIT dialog box lists the EIT file associated with each EIT-*k* (each EIT-*k* represents a three hour time span, and the selection box includes four EIT instances by default). The selection box indicates the file name, PID, and table type (time span) for each EIT instance included in the configuration file. The word *none* appears next to EIT-*k* instances without an associated EIT file.

You can modify, delete, or add EIT instances using one of the command buttons described in the following list:

- **Modify.** The Modify command button opens another EIT dialog box with the selected EIT file name shown in the file name field. Use this button to associate an EIT file with an EIT instance. (See step 2 below.) Double-clicking an EIT instance in the selection box has the same effect.
- **Modify All.** The Modify All command button opens the PSIP table editor with all of the EIT files shown in the EIT selection box open and the first time span displayed (EIT-0). Any changes to the EIT files that you save in the table editor will be applied to the configuration file after you apply the changes in the EIT dialog box.
- **Remove.** The Remove command button deletes the selected EIT instance from the configuration file. (The file remains unchanged on your system disk.)
- **Add.** The Add command button opens the Add EIT dialog box (see page 3-71). Using this dialog box you can add another EIT time span to the configuration file, and specify the PID and table type value for the new EIT instance. You cannot add a time span that is already specified in the selection box.
- **Add All.** The Add All command button opens the Add All EIT dialog box (see page 3-73). Using this dialog box you can add all EIT time spans at once, provided the file names follow the naming restrictions for EIT files.
- **OK.** This command button confirms the changes you have made and closes the dialog box.
- **Cancel.** This command button closes the dialog box without making any changes to the configuration file.

Associating EIT Table Files. To associate an EIT file with an EIT instance, use the following procedure:

1. Double-click the **EIT** icon in the PSIP hierarchy to display the EIT dialog box.
2. In the EIT selection box, highlight an EIT instance and click **Modify**. The following EIT dialog box is displayed. If no EIT file is currently associated with the EIT-*k* instance, *none* is displayed in the file name field.

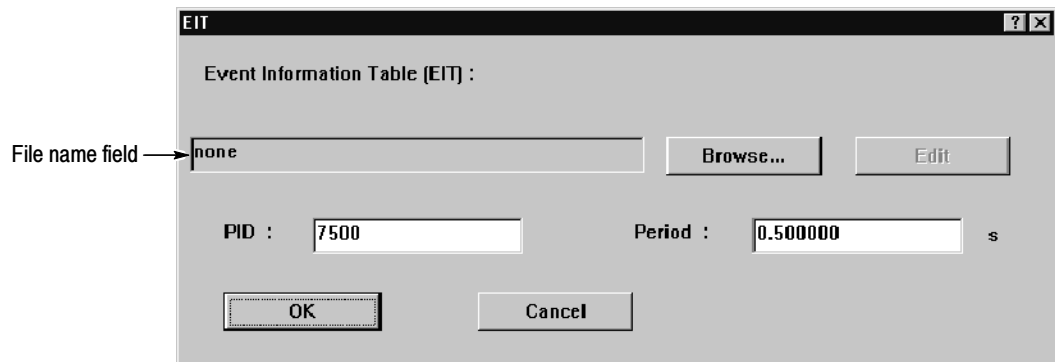

3. Click **Browse** in the EIT dialog box. This opens the Selection PSIP File dialog box.
4. Using standard Windows techniques, locate and select **Atsc_000.EIT**, and then click **OK**. This returns you to the EIT dialog box and **Atsc_000.EIT** is showing in the file name field.
5. Click **Edit** to open the **Atsc_000.EIT** template file in the PSIP table editor.

The EIT template files for the PSIP table editor do not include sections, events, titles, descriptors, or other EIT elements. You need to modify the templates files to create a set of EIT that are valid for your configuration file.

6. Modify the file as necessary, and then select **Save As** from the File menu.
7. Rename the file as *abc...nnn.EIT*, where *abc...* are the characters used in the file name (usually the name of your configuration file without the extension) and *nnn* is a three integer designator for the EIT time span index (000 through 127). The three integer designator immediately precedes the file name extension.

NOTE. This file naming convention allows you to add multiple time spans to your configuration file using the procedure described on page 3-73. In order to add more than one EIT or ETT time span at a time, the files need to be named using the conventions described in step 6, and they must be located in the same directory. See File Naming Constraints on page 3-111 for more information about naming EIT and ETT files.

8. Exit the table editor; you are returned to the EIT dialog box.

9. Select **Browse** from the EIT dialog box, locate and select the new *.EIT file in the Selection PSIP File dialog box (in this example, AtscTV_000.EIT), and then click **OK**.
10. Click **OK** again to accept your changes and dismiss the EIT dialog box. The EIT selection box is updated with the new file for the selected time span.

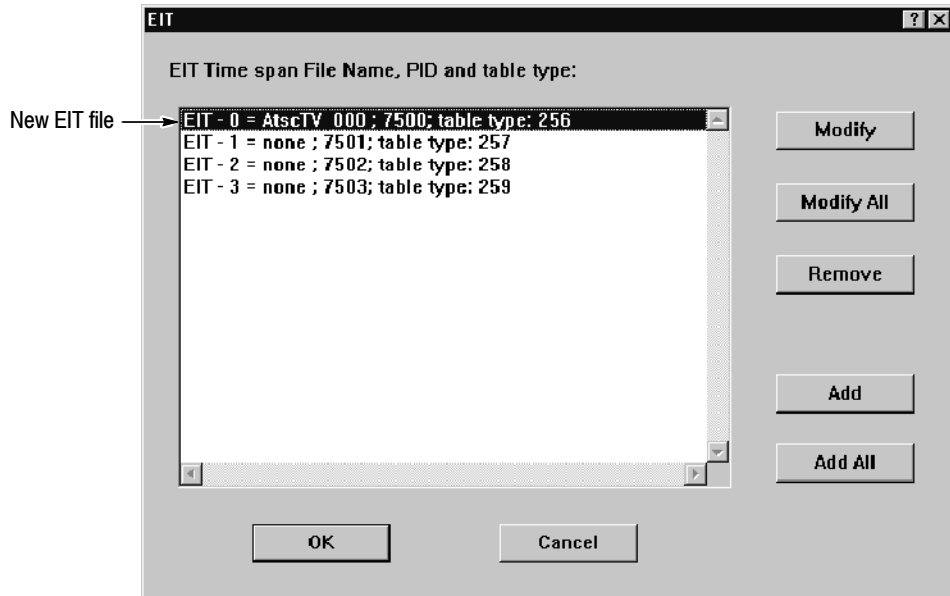

11. Repeat steps 1 through 10 for the remaining time spans, selecting the appropriate time span template files as needed.
12. After you have added all of the time spans required for your configuration file, click **OK** to accept your changes, close the dialog box, and return to the Hierarchic view.

Adding an EIT Instance. To add EIT instances to the configuration file one at a time, use the following procedure (if you want to add multiple instances at once, use the procedure beginning on page 3-73):

1. In the EIT dialog box, click **Add**. The Add EIT dialog box is displayed with *none* showing in the file name field.

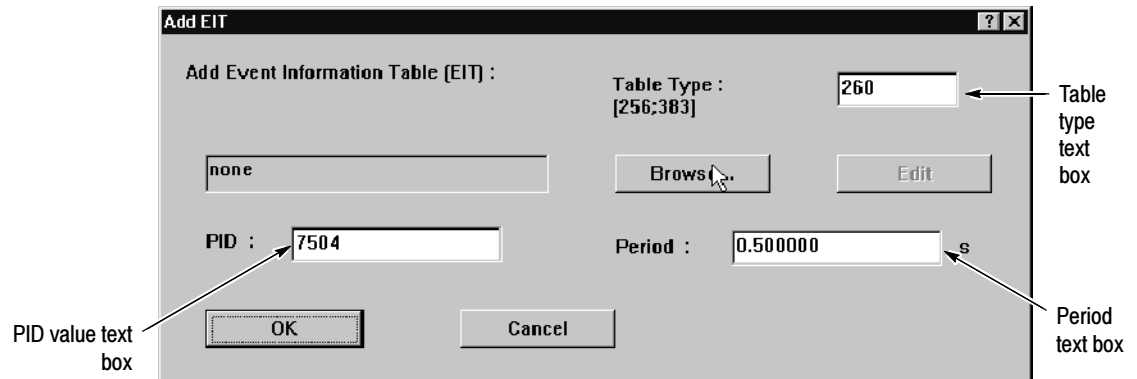

Note that the PID value and the Table Type values are already provided. These default values are inserted based on the number of EIT files already associated with the EIT icon (for the table type value) and the PID of the latest EIT-*k* instance (the PID for new EIT instance is incremented by one). For example, if your configuration file already has EIT instances for time spans zero through three, the next EIT instance is EIT-4, and the table type value for that EIT is 260. If the PID value for EIT-3 is 7503, then the PID value listed in the text box for the next EIT instance is 7504.

2. Click **Browse**, select one of the EIT template files from the Selection PSIP File dialog box, and then click **OK**.
3. Click **Edit** in the EIT dialog box and the PSIP table editor opens, displaying the selected template file.
4. Modify the file as needed, and then select **Save As** from the File menu. Name the EIT file using the naming requirements described in *File Naming Constraints* on page 3-104. (For example, if you are adding a fifth EIT instance, name the file *newAtsc_004.EIT*.)
5. Exit the table editor to return to the Add EIT dialog box with the template file name showing in the file name field.
6. Click **Browse**, and then locate and select the new EIT file in the Selection PSIP File dialog box.
7. Click **OK** to close the dialog box; the Add EIT dialog box reappears.

8. Edit the EIT period if necessary, and then click **OK** to close the Add EIT dialog box. The EIT selection box is updated showing the new EIT instance at the bottom of the list.

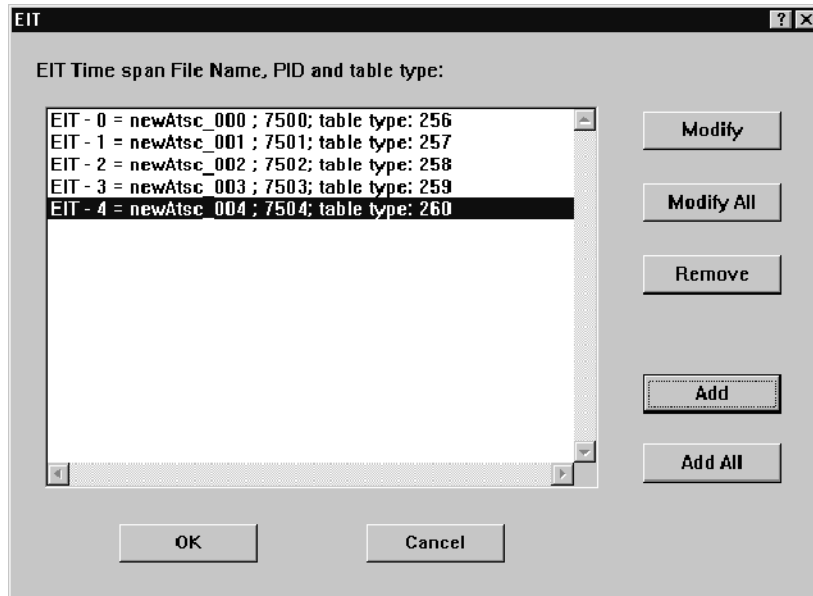

9. Click **OK** to accept your changes, close the dialog box, and return to the multiplexer. The new EIT instance is associated to the EIT icon. Note the text changes to the right of the EIT icon (increased rate and time spans).

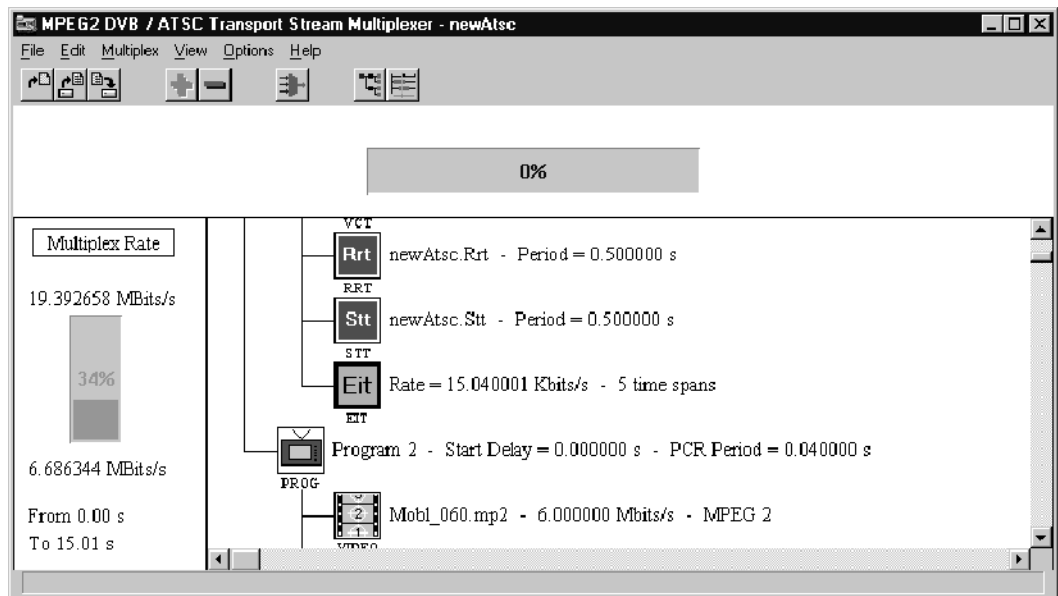

Adding Multiple EIT Instances. You can also add all of the time spans you need for your configuration file at once using the following procedure.

1. In the multiplexer, double-click the **EIT** icon.
2. Remove all of the instances in the EIT selection box by highlighting each instance individually and clicking **Remove**. This does not delete the EIT files from your system disk. It simply removes those files from your configuration file.

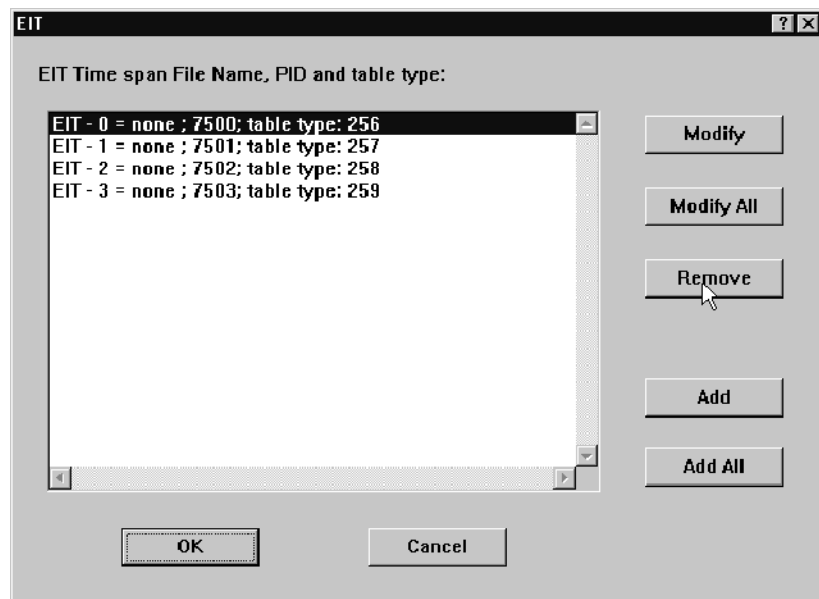

3. Click the **Add All** command button.
4. Click **Browse** in the Add All dialog box.
5. Select an EIT template file from the Selection PSIP File dialog box, and then click **OK** to accept your selection and close the dialog box.
6. Click **Edit** in the Add All EIT dialog box. The PSIP table editor is opened with the EIT-0 file displayed (the other EIT times spans are also open in the table editor, but are not visible).

7. Save the open time spans (each time span is an EIT file) using the following procedure:
 - a. With the first time span displayed (in this example, *EIT-0*), select **Save As** from the File menu.
 - b. Rename the file using the naming conventions described in *File Naming Constraints* on page 3-104 (in this example, *newAtsc_000.EIT*).

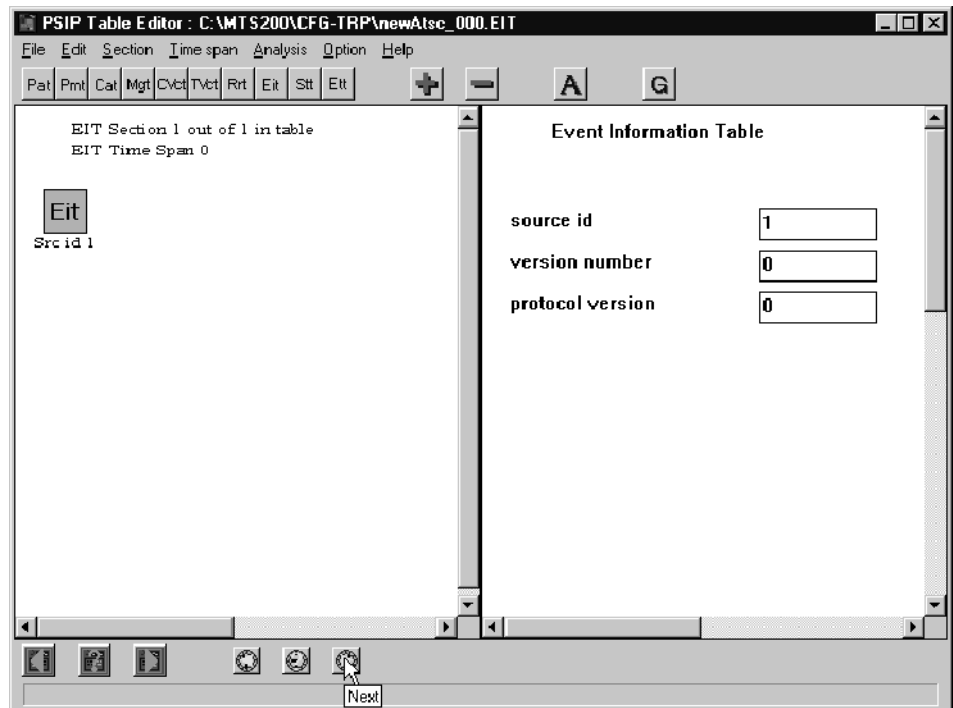

- c. Click the **Next** command button on the lower toolbar to display the second time span.
- d. Repeat steps a through c to rename the remaining time spans (EIT-1 through EIT-3) using the naming conventions described in *File Naming Constraints* on page 3-104.

8. Select **New** from the Time Span menu. The EIT Instance Selection dialog box is displayed.

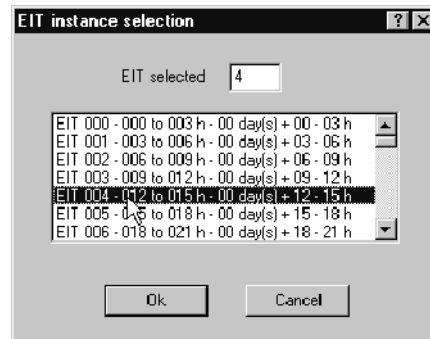

9. Select the next time span (in this example, EIT 004), and then click **OK**.
10. Save the new time span using the naming conventions described in *File Naming Constraints* on page 3-104.
11. Repeat steps 8 through 10 for all of the EIT instances you need to create for your configuration file, and then exit the table editor.
12. In the Add All EIT dialog box, click **Browse**, and then locate and select one of the newly named EIT-*k* instances (you do not have to select the EIT-0 instance).
13. Click **OK** in the Selection PSIP File dialog box and you are returned to the Add All EIT dialog box. The Table Type, PID, and Period text boxes show the default values; these values apply to the EIT-0 instance of the set of EIT files to which the file showing in the file name field belongs.

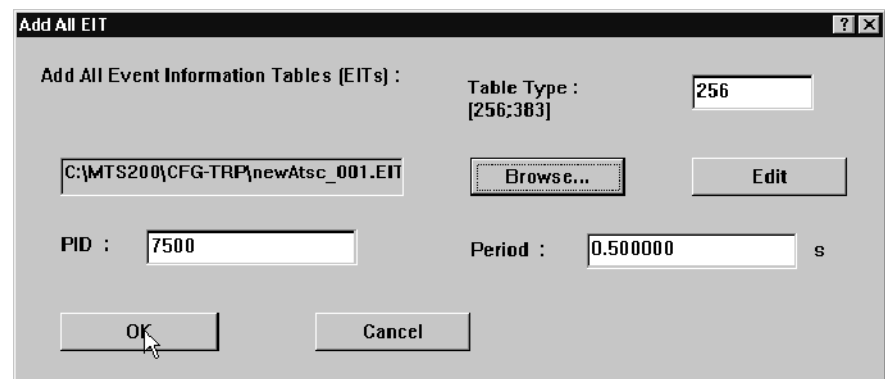

14. Click **OK** to close the Add All EIT dialog box; you are returned to the EIT dialog box. The dialog box is updated showing all of the EIT time spans that you have added.

If one or more instances that you thought you added are not included in the selection box, ensure that you followed the naming conventions described in *File Naming Constraints* on page 3-104, and that the files are all located in the same directory.

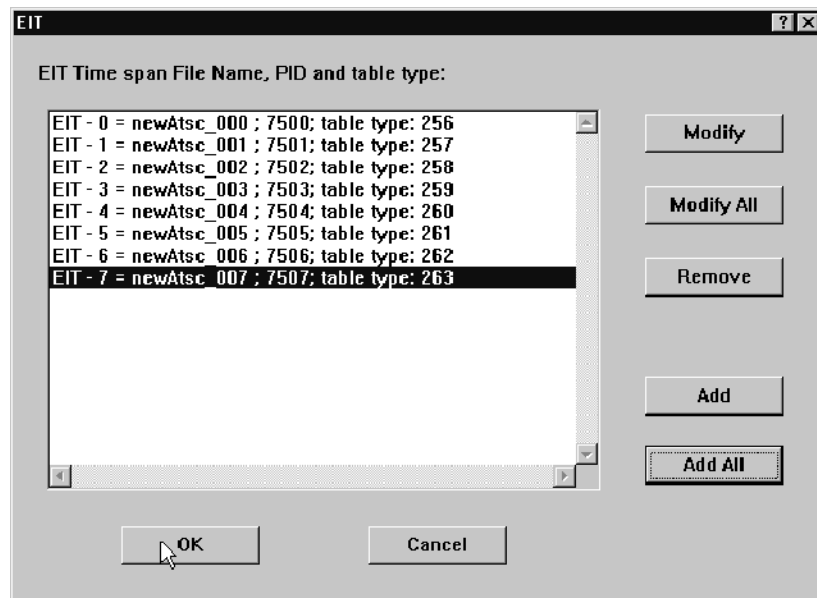

15. To edit the EIT period or PID value, click **Modify**, and then make the changes in the EIT dialog box that is displayed.
16. To add EIT elements to, or to modify all all of the EIT instances in the selection box, click **Modify All**. All of the EIT instances will be opened in the PSIP table editor with time span zero displayed. Any changes to the files that you save in the table editor will be reflected in the configuration file once you apply the changes in the multiplexer.
17. Click **OK** in the EIT dialog box to apply your changes and close the dialog box. All of the EIT files will be associated with the configuration file.

Adding ETT Instances. Extended text tables (ETT) are optional in the ATSC environments and are used to provide additional textual information about the channels and events described in the VCT and EIT. There are two types of ETT: Channel ETT and Event ETT. The procedures in this section describe how to add and edit event ETTs to the ATSC environments. For more information about creating and modifying ETTs, see *Using the DVB and PSIP Table Editors* beginning on page 3-93.

1. Select the PSIP icon, and then click **+** (or select **Add** from the Edit menu).
2. In the dialog box displayed, click **ETT**, and then click **OK**. The Add ETT dialog box is displayed.

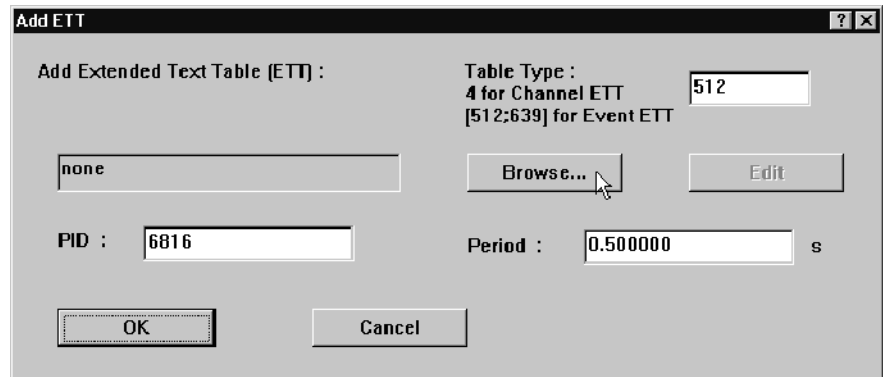

3. Click **Browse** to display the Selection PSIP File dialog box.
4. Select the event ETT template file, *Atsc_001.ETT*, and then click **OK**.
5. Click **Edit** in the Add ETT dialog box to start the PSIP table editor with the ETT template file displayed.
6. In the PSIP table editor, select **Save As** from the File menu and save the ETT file using the conventions described in *File Naming Constraints* on page 3-111.
7. Exit the PSIP table editor and return to the Add EIT dialog box.
8. Click **Browse**, and then select the ETT file you just created.
9. Edit the Table Type, PID, and period as necessary, and then click **OK** to accept your changes and return to the multiplexer. The ETT icon is added to the PSIP hierarchy and the file you selected is now associated with the ETT icon.

You can now use the procedures described for adding and editing EIT instances to modify, add, and delete ETT instances:

- To modify the table type, PID, or period of an ETT instance, use the procedure beginning on page 3-67.
- To add one ETT instance to your configuration file, use the procedure beginning on page 3-71.
- To add multiple instances to your configuration file, use the procedure beginning on page 3-73.

Adding and Editing ARIB Tables

The ARIB icon is present in the Multiplexer hierarchy when ISDB-S/ARIB is selected in the Options menu. To add ISDB-S/ARIB information to your configuration file, select ISDB-S/ARIB from the Options menu.

To add ARIB table icons to the hierarchy and edit certain configuration file parameters, use the following procedure:

1. Select the ARIB icon, and then select + (the Add button). The following dialog box is displayed. This dialog box allows you to associate a specific ARIB table file to your configuration file, start the ARIB Table Editor with the selected file displayed, and set the period for the selected ARIB table.

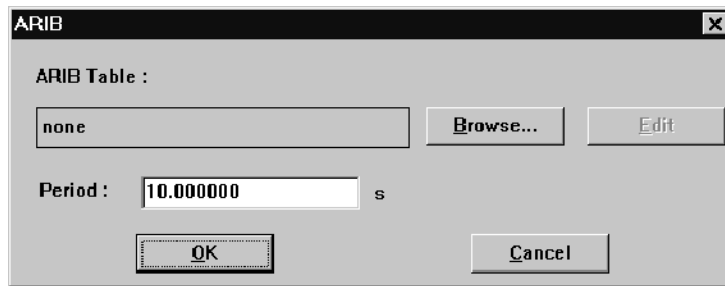

Click **Cancel** any time this dialog box is displayed to close the dialog box without adding items to the hierarchy or changing the configuration file.

If you are working with a new configuration file, the table file name in the file name field is none. To associate an ARIB file with an ARIB icon in the hierarchic view, continue with the procedure:

2. From the table dialog box, click **Browse**.
3. Navigate to and select an ARIB table (DCT, DLT, BIT, SDTT, SIT or DIT), and then select OK. The table type is analyzed; only ARIB tables are accepted.
4. To edit the ARIB file indicated in the file name field, click **Edit**. The ARIB Table Editor will start with the selected table file displayed.
5. From the table editor, save the table file under a new name (usually the name of the configuration file).

NOTE. Be sure that you exit the ARIB table editor before you continue to use the Multiplexer.

6. Click **Browse** and select the table file you just created.
7. To change the period of the selected table, edit the Period text box.

8. After you have made all the changes you want using the dialog box shown in the previous illustration, click **OK**.
9. An icon for the table type is added to the Hierarchic view, and the configuration file is updated with the changes you have made.

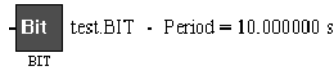

Setting ARIB Table Periods. To set the periods for the DCT, DLT, SDTT, BIT, SIT and DIT, use the following procedure.

1. Double click the ARIB icon in the hierarchic view to display the ARIB Period dialog box.

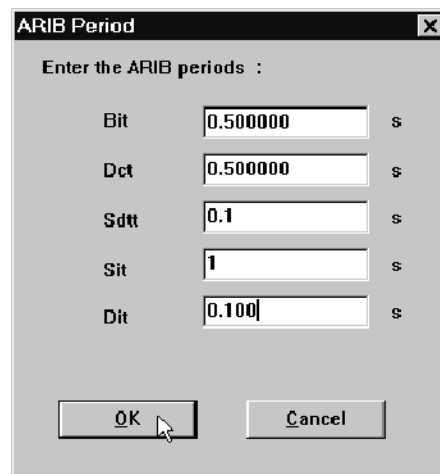

2. Change the period as appropriate and then click **OK** to accept your changes and close the dialog box, or click **Cancel** at any time to close the dialog box without making any changes to the ARIB periods.

Adding DLT Tables. Use the following procedure for adding DLT tables to your configuration file:

1. Double click the DLT icon in the ARIB hierarchy to display the DLT dialog box.

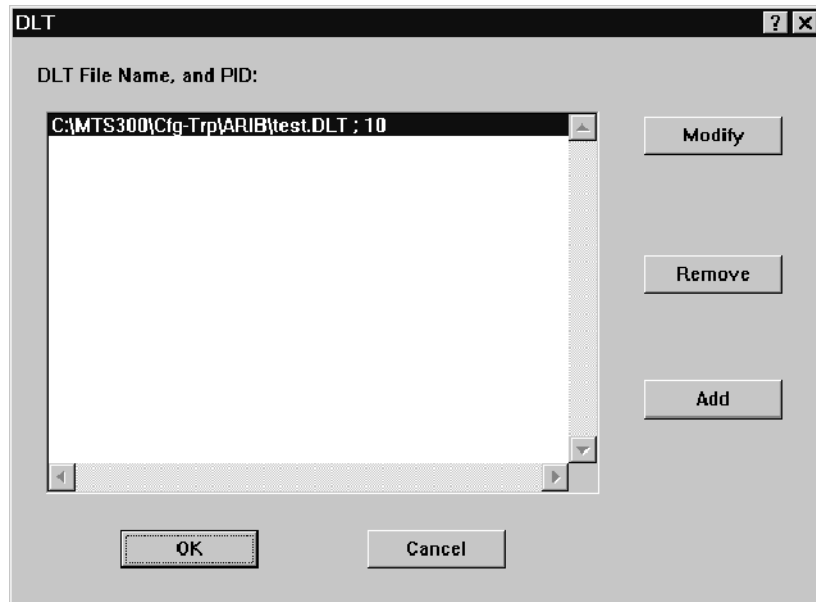

The selection box indicates the file name and PID for each DLT included in the configuration file. You can modify, delete or add DLT instances using one of the command buttons described in the following list:

- **Modify.** The modify command button opens another DLT dialog box with the selected DLT file name in the file name field. Double clicking a DLT in the list has the same effect.
- **Remove.** The remove command button deletes the selected DLT Table from the configuration file. (The file remains unchanged on your system disk.)
- **Add.** The Add command button opens the Add DLT dialog box. Using this dialog box you can add another DLT table to the configuration file, and specify its PID value.
- **OK.** This command button confirms the changes you have made and closes the dialog box.
- **Cancel.** This command button closes the dialog box without making any changes to the configuration file.

Associating DLT Table Files. To associate an DLT file, use the following procedure:

1. Double click the DLT icon in the ARIB hierarchy to display the DLT dialog box.
2. In the DLT selection box, highlight an DLT Table and click **Modify**. The following dialog box is displayed:

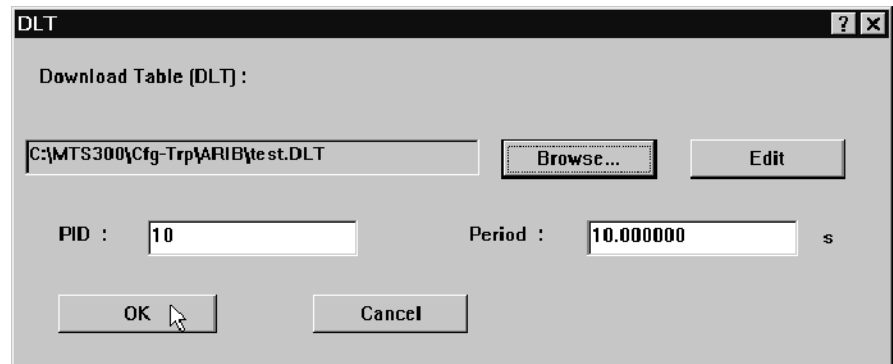

3. Click **Browse** in the DLT dialog box. This opens the Selection ARIB file dialog box.
4. Using standard Windows techniques, locate and select a DLT file, and then click **OK**. This returns you to the DLT dialog box and selected DLT file name is showing in the file name field.
5. Click **Edit** to open the DLT file in the ARIB Table Editor.
6. Modify the file as necessary, and select **Save As** from the file menu.
7. Rename the file (usually the name of your configuration file without the extension).
8. Exit the ARIB table editor, you are returned to the DLT dialog box.
9. Select Browse from the DLT dialog box, locate and select the new DLT file.
10. Click OK to accept your changes and dismiss the DLT dialog box. The DLT Selection box is updated with the new file.
11. Repeat steps 1 through 10. After you have added all the DLT tables required for your configuration file, click **OK** to accept your changes, close the dialog box and return to the Hierarchic view.

Adding a DLT Table. To add DLT tables to the configuration file, use the following procedure:

1. In the DLT dialog box, click **Add**. The Add DLT dialog box is displayed with *none* showing in the file name field.

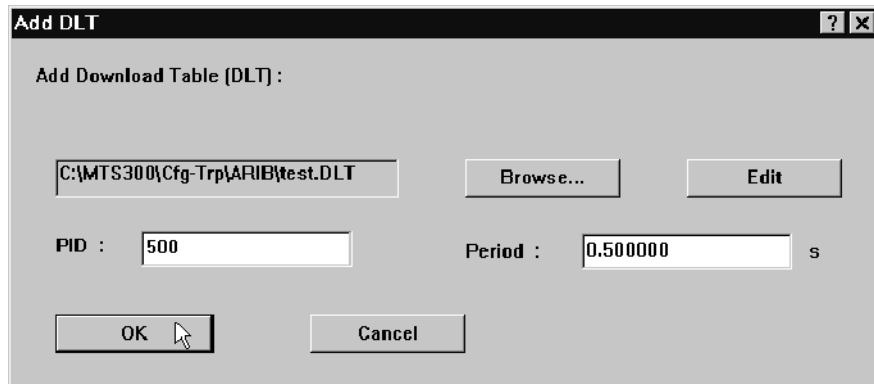

Note that the PID value is already provided. This default value is based on PID of the latest DLT table (the PID for new DLT table is incremented by one.)

2. Click **Browse**. Select one of the DLT files in the Selection ARIB file dialog box, and then click **OK**.
3. Click **Edit** in the ARIB dialog box and the ARIB table editor opens, displaying the selected template file.
4. Modify the file as needed, and then select **Save As** from the file menu.
5. Exit the table editor to return to the Add DLT dialog box with the template file name showing in the file name field.
6. Click **Browse**, and then locate and select the new DLT file in the Selection ARIB File dialog box.
7. Click **OK** to close the dialog box; the Add DLT dialog box reappears.

8. Edit the DLT period if necessary, and then click OK to close the Add DLT dialog box. The DLT Selection dialog box is updated showing the new DLT file at the bottom of the list.

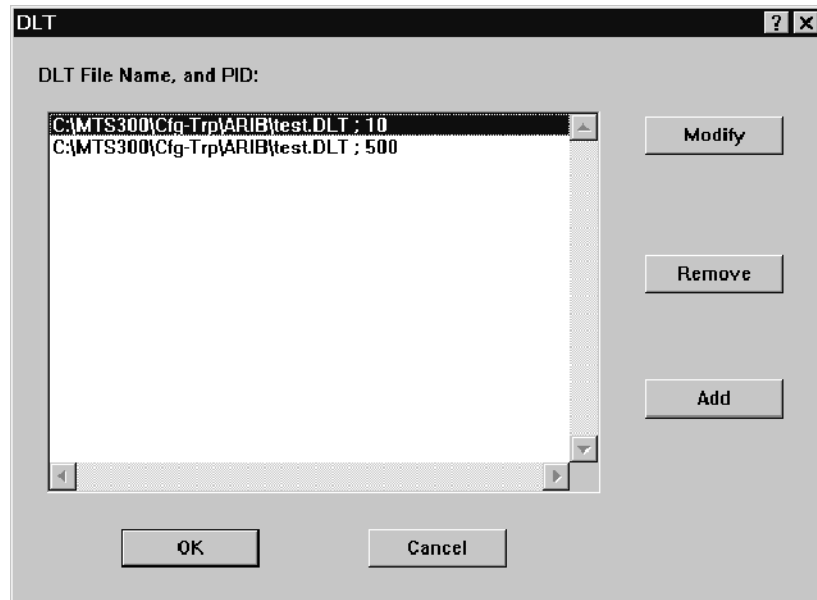

9. Click OK to accept your changes, close the dialog box, and return to the multiplexer.

Note the text changes to the right of the DLT icon (increased rate and number of tables)

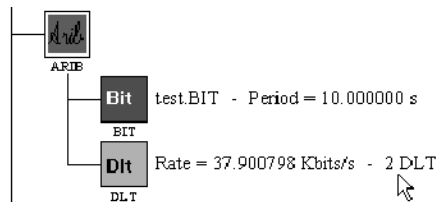

Generating a Multiplex

Once you have finished creating a configuration file, you may generate the described multiplex/transport stream by choosing Go from the Multiplex menu or by clicking the Go button on the toolbar.



Go (generate a multiplex)

If the configuration file definition is not complete, transport stream generation does not begin, and a message box appears to indicate the problem. The multiplex definition is not complete in the following cases:

- There is an empty program (a program without an elementary stream).
- There is an undefined elementary stream or the multiplexer cannot find the linked file.

After you have ensured that the configuration file data is valid, supply a file name for the transport stream file. The default is the current configuration name with the *.trp extension.

The duration gauge shows the progress of multiplex generation.

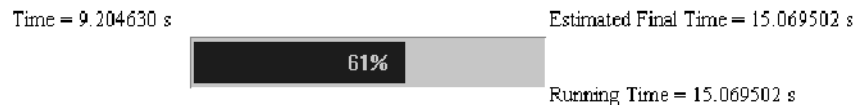

Times shown are “real” stream times; actual *.trp file generation takes much longer.

- Time (on the left side of the gauge) indicates the stream time elapsed since the beginning of the stream; it is equivalent to bits written divided by the multiplex rate.
- Estimated Final Time is an estimate of the duration of the entire stream.
- The percentage shown on the gauge is the current Time (on the left side of the gauge) divided by the Estimated Final Time (times 100).
- Running Time shows the actual stream duration after generation is complete.

During transport stream file generation, multiplexer commands are disabled (grayed). Press the ESC key to stop multiplex calculation at any time.

An Example Configuration File

You can view (and edit) configuration files with a text editing application such as Notepad. An example of a configuration file is shown below. Each heading is enclosed in brackets.

```
[MUX]
CountProg=3
Mux Rate=10.000000
Global time=0.000000
Type of scrambling=0
DVB Option=1
ARIB Option=0
Terrestrial ATSC Option=0
Cable ATSC Option=0
Mega frames Option=0
Dynamic SI Option=0

[PSI]
PAT Period=0.010000
PMT Period=0.100000
CAT Period=0.100000
Transport Stream ID=1
NIT PID=16
PID PMT 1=32
PID PMT 2=48
PID PMT 3=64
CAT=0
Nb EMM=0
TSDT=0

[SI]
BAT=1
SDT=1
EIT=1
TDT=1
RST=0
TOT=0
NIT File=C:\MTS300\Cfg-Trp\dvb.NIT
NIT Period=0.500000
BAT File=C:\MTS300\Cfg-Trp\dvb.BAT
BAT Period=0.500000
SDT File=C:\MTS300\Cfg-Trp\dvb.SDT
SDT Period=0.500000
EIT File=C:\MTS300\Cfg-Trp\dvb.EIT
EIT Period=0.500000
TDT Start Date=12/31/2000
```

TDT Start Time=01:00:00
TDT Period=0.100000

[Prog 1]
Nb Video=1
Nb Audio=1
Nb Data=0
Nb Splice=0
Nb ECM=0
PCR period=0.040000
Starting time=0.000000

[Video Stream 1 Prog 1]
Video file=C:\MTS300\Video\525\Mob1_060.mp2
Rate=6.000000
PES packet size=2048
Initial delay=0.000000
Scrambling=0
Offset DTS=0.290411
MPEG=2
Profile Level=132
Chroma format=1
vbv size=229376
Nb frames per s=29.969999
Horizontal size=704
Vertical size=480
Stream Id=224
Picture=1.000000
Sequence header=0
Position SH=0

[Audio Stream 1 Prog 1]
Audio file=C:\MTS300\Audio\10khz.mp2
Rate=0.128000
PES packet size=2048
Initial delay=0.000000
Scrambling=0
Offset PTS=0.032000
Layer=2
ID=1
Sampling frequency=48.000000
Protection=1
Mode=3
Nb Slots=384
Standard type=1
Delta_t_AU=0.024000
Stream Id=193

```
[Prog 2]
Nb Video=1
Nb Audio=1
Nb Data=0
Nb Splice=0
Nb ECM=0
PCR period=0.040000
Starting time=15.020000

[Video Stream 1 Prog 2]
Video file=C:\MTS300\Video\625\Demo_015.mp2
Rate=1.500000
PES packet size=2048
Initial delay=0.000000
Scrambling=0
Offset DTS=0.691222
MPEG=2
Profile Level=132
Chroma format=1
vbv size=135168
Nb frames per s=25.000000
Horizontal size=352
Vertical size=288
Stream Id=224
Picture=1.000000
Sequence header=0
Position SH=0

[Audio Stream 1 Prog 2]
Audio file=C:\MTS300\Audio\10khz.mp2
Rate=0.128000
PES packet size=2048
Initial delay=0.000000
Scrambling=0
Offset PTS=0.032000
Layer=2
ID=1
Sampling frequency=48.000000
Protection=1
Mode=3
Nb Slots=384
Standard type=1
Delta_t_AU=0.024000
Stream Id=193

[Prog 3]
Nb Video=1
Nb Audio=1
```

Nb Data=0
Nb Splice=0
Nb ECM=0
PCR period=0.040000
Starting time=20.700001

[Video Stream 1 Prog 3]
Video file=C:\MTS300\Video\625\Demo_015.mp2
Rate=1.500000
PES packet size=2048
Initial delay=0.000000
Scrambling=0
Offset DTS=0.691222
MPEG=2
Profile Level=132
Chroma format=1
vbv size=135168
Nb frames per s=25.000000
Horizontal size=352
Vertical size=288
Stream Id=224
Picture=1.000000
Sequence header=0
Position SH=0

[Audio Stream 1 Prog 3]
Audio file=C:\MTS300\Audio\10khz.mp2
Rate=0.128000
PES packet size=2048
Initial delay=0.000000
Scrambling=0
Offset PTS=0.032000
Layer=2
ID=1
Sampling frequency=48.000000
Protection=1
Mode=3
Nb Slots=384
Standard type=1
Delta_t_AU=0.024000
Stream Id=193

Using Option CA: Scrambling / Conditional Access

To create a stream with scrambled components, you must first enable Option CA and copy the appropriate EMM and ECM sample files onto the computer system disk. Version 6.0 of the MPEG Test System software includes simple example files, Sample.emm and Test.ecm in the C:\MTS300\Cfg-trp directory.

Activating Option CA

If you purchased Option CA with your MPEG Test System, it is already activated. If you are adding Option CA to a test system, you must perform the following steps to activate the option:

1. Exit the multiplexer or the MPEG-2 System Analyzer if either application is running.
2. Double-click the **License Manager** icon (located in the Tektronix MPEG Test System program group window) to start the application.

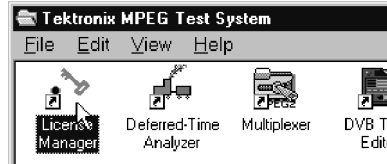

The Tektronix Software Protection window appears.



3. Consult the password document supplied with your Option CA upgrade kit and identify the General password. Enter the three 6-character Hexadecimal numbers of the password in the corresponding window entry fields (lower-case characters are acceptable) and then click **OK**. A License message window appears.

4. If the password is correct, click **OK** to acknowledge the message. If you made an error entering the password, click **OK** and return to step 3.

When you enter the correct password, Option CA is available the next time you start the multiplexer or MPEG-2 System Analyzer.

Creating a Stream with Scrambled Components

Creating a scrambled stream is a five step process:

- Create a configuration file.
- Add a CAT to the PSI hierarchy, and designate the scrambling algorithm to use.
- Add an EMM to the CAT, and associate a
- Add an ECM to each program icon with streams that will be scrambled.
- Designate which streams

Use the following procedure to create a stream with scrambled components:

1. Create the configuration (.cfg) file with all required tables (PSI/SI/PSIP) and elementary streams.
2. Select **Scrambling** from the Options menu and then choose the appropriate scrambling algorithm (CCETT or DVB) from the resulting Type of scrambling window. Click **OK** to confirm the choice and close the window.

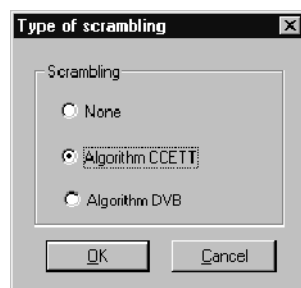

3. For conditional access scrambling, add a conditional access table (CAT) and associated entitlement management messages (EMM):
 - a. Highlight the PSI hierarchic icon and then click **+** (**Add**).
 - b. Click the CAT option in the dialog box, and a CAT icon is added to the PSI hierarchy.

- c. Highlight the new CAT icon and then click + (**Add**) again. An EMM icon is added below the CAT.

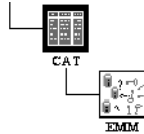

- d. Double-click the EMM icon to open an EMM Stream window.

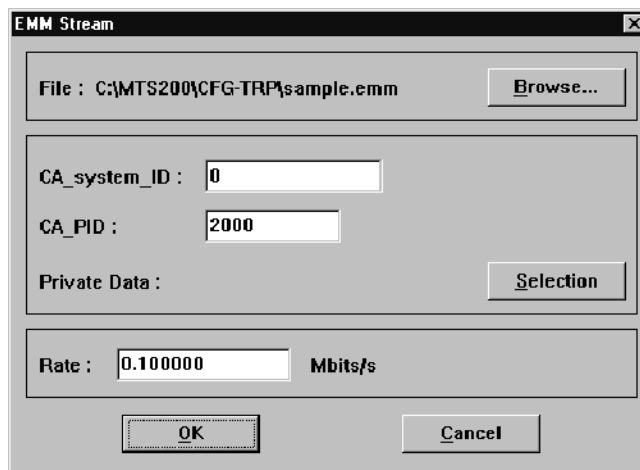

- e. Click **Browse** to locate and select an EMM file.
 - f. After selecting an EMM file, make all necessary changes to the fields in the EMM Stream dialog box
 - g. Click **OK** to accept your changes and close the dialog box, or click **Cancel** to close the dialog box without making any changes.
 - h. Repeat steps a through g as necessary to add all required EMMs.
4. Add an Entitlement Control Message (ECM) to each program that will have scrambled streams:
 - a. Highlight the PROG icon of the program and then click + (**Add**).
 - b. Select **ECM** in the resulting Stream to add dialog box.
 - c. Click **OK** to confirm the choice and close the window. An ECM icon is added to the program hierarchy.

- d. Double-click the new **ECM** icon to display the ECM Stream dialog box.

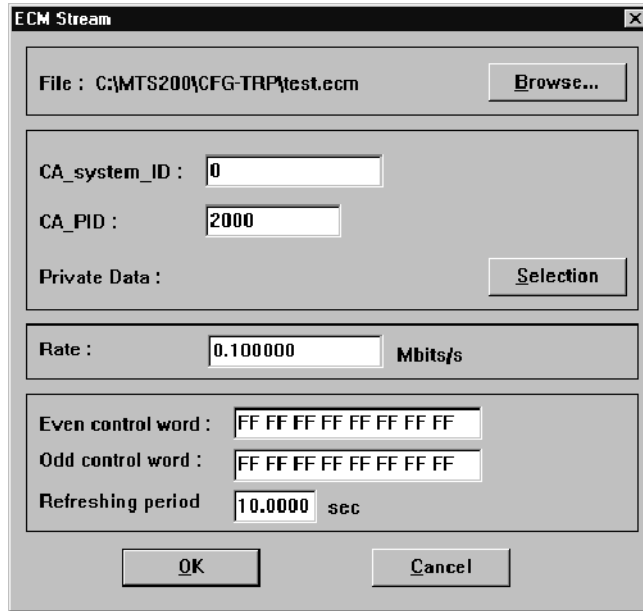

- e. Click **Browse** to locate and select an ECM file. You can only select appropriate file types.
 - f. When you are finished making changes to the fields in the ECM Stream dialog box, click **OK** to accept your choices and close the dialog box. Click **Cancel** to close the dialog box without making any changes.
5. Designate the elementary streams to be scrambled:
- a. Double-click the Video, Audio, or Data elementary stream icon (in a program that now has an ECM) to open the stream selection/configuration window.
 - b. In the Stream Selection dialog box, click the **Scrambling** check box to designate the elementary stream for scrambling.



- c. Click **OK** to confirm the selection and close the window. The elementary stream icon selected for scrambling will be displayed with a blue padlock scrambling symbol.
- d. Repeat steps 4 and 5 for every elementary stream that is to be scrambled.

Using the DVB, PSIP, and ARIB Table Editors

This section describes DVB and PSIP table editor applications. Because the table editors are similar in design and function, most of the information in this section applies equally to the MTS300 DVB Table Editor, the MTS300 PSIP Table Editor., and the MTS300 ARIB Table Editor. The table item parameters for the DVB and the ATSC table editors are fully described in *PSI, DVB SI, and ATSC PSIP Table Item Parameters* beginning on page 3-143.

In this section, you will find procedures for modifying PSI, SI, PSIP, and ARIB table files by adding, editing, and deleting table items. You will also find procedures for analyzing the open tables, using the DVB and ATSC table editors, as you build them in order to create a set of coherent tables.

The information in this sections is organized as described in the following list:

- *The Application Window* describes the table editor including descriptions of the views, menu commands, icons, and toolbar buttons enabled by the table editors (see page 3-95).
- *Table File Operations* describes basic operations such as creating, opening, saving, and closing table files, and selecting from among the open tables (see page 3-108).
- *Table Sections* describes how to create, insert, delete, and move among table sections and time spans (see page 3-112).
- *Table Items* describes how to add, remove, search for and copy table items such as streams, services, events, and descriptors (see page 3-116).
- *Table Analysis* describes the table analyses enabled by the table editors and how to interpret table editor error messages (see page 3-126).
- *Global View* describes how to use the Global view window. This section also shows how the associations among selected SI and PSIP tables are managed (see page 3-132).

Use the table editors to create and edit the components of the MPEG-2 PSI (program specific information), DVB SI (service information), ATSC PSIP (program and system information protocol), and ISDB-S/ARIB (service and system information) tables listed in Table 3-13. Table 3-13 shows which tables can be edited in both applications and which tables can be edited in only one of the table editors.

NOTE. Although you can view and edit the contents of the PAT and CAT, you cannot export changes made to these files to the multiplexer. The PAT and CAT are created and updated dynamically by the multiplexer; PAT and CAT parameters can be edited for configuration files only from within the multiplexer.

Table 3-13: PSI / SI / PSIP Tables

All table editors	PSIP Table Editor	DVB Table Editor	ARIB Table Editor
PAT (Program Allocation Table)	MGT (Master Guide Table)	NIT (Network Information Table)	BIT (Broadcaster Information Table)
PMT (Program Map Table)	VCT (Virtual Channel Table)	SDT (Service Description Table)	DCT (Download Control Table)
CAT (Conditional Access Table)	RRT (Rating Region Table)	BAT (Bouquet Association Table)	DLT (Download Table)
EIT (Event Information Table)	STT (System Time Table)	RST (Running Status Table)	SDTT (Software Download Trigger Table)
	ETT (Extended Text Table)	TOT (Time Offset Table)	DIT ¹ (Discontinuity Information Table)
		TSDT (Transport Stream Description Table)	SIT ¹ (Selection Information Table)

¹ DVB table

NOTE. The table editors comply with ETSI Draft ETS 300 468 and ATSC Standard Doc A/65. Please refer to these documents for more details on parameter values in order to generate correct tables.

The Application Window

You can access the table editors using one of the following techniques:

- Use the Windows Start menu.
- Double-click the icons in the Tektronix MPEG Test System program group window.
- From within the MTS300 MPEG-2 DVB / ATSC / ISDB-S Transport Stream Multiplexer, click Edit in one of the table selection dialog boxes. This method helps to ensure correct association of the table and configuration files.

The figure below shows the default application window with the default PAT table file displayed. Most parts of the table editor application windows are similar for all table types. The contents of the Hierarchic and Edit windows vary depending on the table displayed.

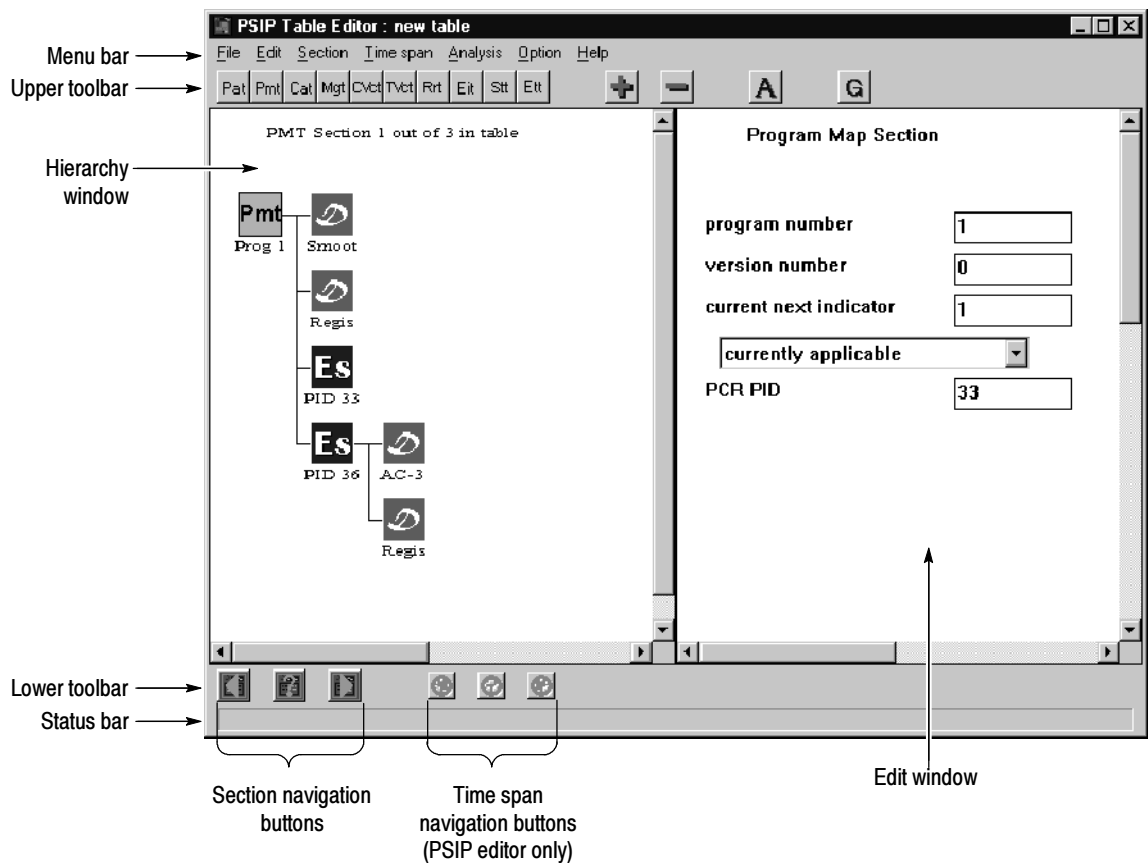

In the DVB and ATSC table editors, you can also display another window, separate from the application window, that shows the association between selected SI and PSIP table files, called the Global view window. See *Global View* on page 3-132 for information about displaying and using this table editor view window.

NOTE. *Most of the illustrations used in this section show the MTS300 PSIP Table Editor in use. Unless otherwise stated, these illustrations can be applied to both table editors. Significant differences between the two interfaces and descriptions are indicated in the text and in some cases with separate illustrations.*

Hierarchy Window

The Hierarchy window displays the structure of the currently selected table. Add and delete table items in this view.

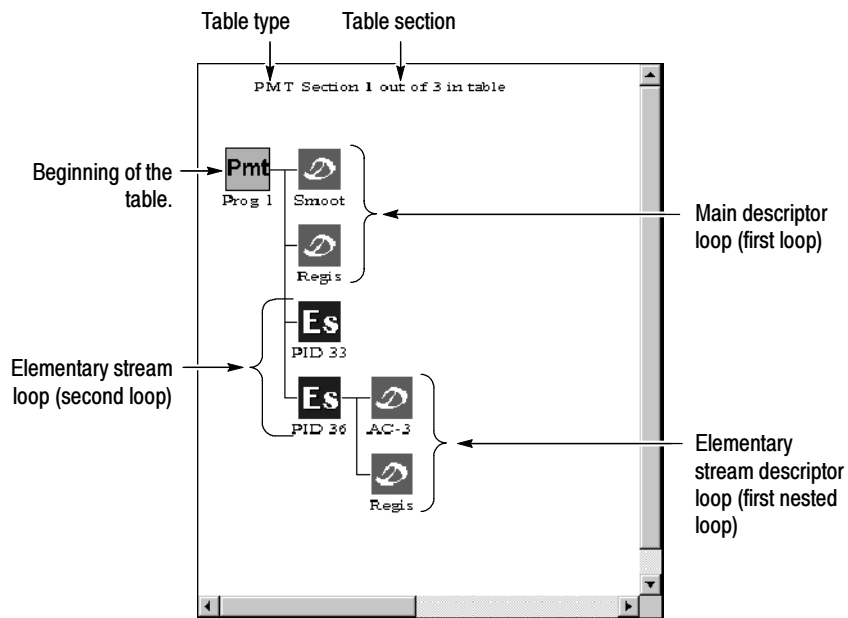

The structure of the table sections are depicted as a hierarchy of icons (only one section is displayed at a time). Each icon represents a logical part of the table structure. Loops in the table data structures are shown as subordinate parts of the hierarchy.

You can collapse or expand a table hierarchy by double-clicking an icon that has subordinate parts. If a part of a table is collapsed, the icon at the top-level of the collapsed part of the hierarchy appears three-dimensional. Double-click the icon to expand the table at that point.

The following list describes the other features of the Hierarchic view:

- **Table type.** An abbreviation for the current table is listed in the top line of view window.
- **Table section.** Most tables are made up of multiple sections. The top line in the Hierarchic view indicates which section of the table is currently being edited. It also indicates how many sections make up the table.

Depending on the table type, the meaning of sections (what they correspond to in the bitstream syntax) vary. For instance, PAT sections refer to transport streams; whereas, PMT sections relate to separate programs. For the EIT, sections relate to different events on specific channels (PSIP) and different services (DVB). See Table 3-23 on page 3-113 for descriptions of what table sections represent.

- **Table item icons.** Each logical part of a table is associated with an icon that depicts the part of the table being edited. The type of information being edited is generally depicted by the icon graphic. See Table 3-22 on page 3-104 for more information about what each icon in the Hierarchic view represents.

Edit Window

Use the Edit window to display and edit parameters of the currently selected table item icon. Add and delete table items in the Hierarchy window.

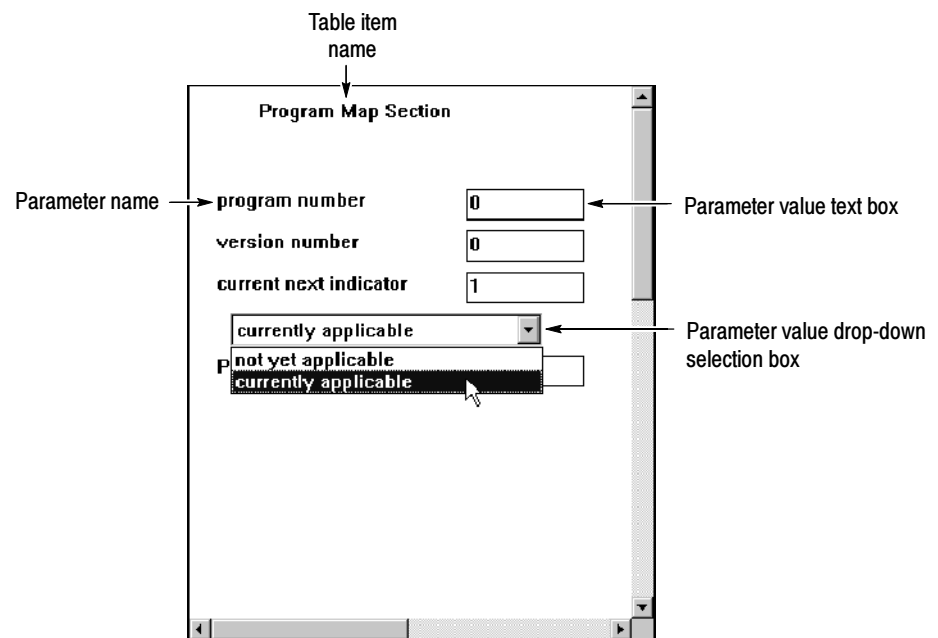

The following list describes some of the features of the Edit view:

- **Table item name.** The top line of the window displays the name of the table item currently being edited, and it changes as you select different icons in the Hierarchic view.
- **Parameter name.** The parameter name identifies the parameter you are editing.
- **Parameter value text box.** Each part of a table structure has parameters that you can edit. Usually, the default value of the parameter is displayed, or it is zero or left blank. However, since the both the table editor and the MTS300 MPEG-2 DVB / ATSC / ISDB-S Transport Stream Multiplexer can edit the same file, when you start the table editor from within the multiplexer, some parameter values are non-default values. For instance, you can set PID values for some tables from the multiplexer; if you start the table editor with the edited file after changing the PID values, the changes are reflected in the Edit view.
- **Parameter options selection box.** Some table parameters can only take a limited set of values, usually expressed as options. In such cases, choose the appropriate option from a drop-down selection box, as shown in the previous illustration. The parameter value text box immediately preceding the drop-down selection box changes to show the value for the option you have chosen.

Menu Commands

The following section lists the commands available from the Menu bar and explains their function and use.

File Menu. The File menu (Table 3-14) provides file management commands. Use it to access the Global View, open new or existing table files, and close the application.

Table 3-14: Table editor File menu commands

Use	To
New	Create a new table file.
Open	Open an existing table file.
Save	Save the current selection to disk.
Save as	Save the current selection with a new file name.
Save All	Save all open tables to their respective files.
Close	Close the currently selected table.
Close All	Close all of the open table files (ATSC Table Editor only).

Table 3- 14: Table editor File menu commands (Cont.)

Use	To
Global View	Show the association between selected NIT, SDT, and EIT table files (DVB), or the selected VCT, EIT, and ETT table files (ATSC).
Printer Setup	Set paper orientation, paper size, and printer.
Print	ATSC Table Editor only — Select from one of the following options:
Hierarchical View	Print the contents of the Hierarchic view.
Edit View	Print the contents of the Edit view.
Global View	If displayed, print the contents of the Global view.
Exit	Exit (quit) the application.

Below the Exit menu selection is a list of table types that the table editor can display. When you select one of these table types, the table editor displays the currently open table. If no table of the selected type is open, a dialog box is displayed that allows you to create a new file or open an existing table file.

Edit Menu. The Edit menu (Table 3-15) allows you to add and delete items from the table files.

Table 3- 15: Table editor Edit menu commands

Use	To
Add	Add various items to the table file.
Delete	Delete the currently selected item and all its sub-items. Deleted items are not copied to the Windows clipboard. (The main icon cannot be deleted.)
Find	Complete the dialog boxes to search for section-specific information in a table. (DVB Table Editor only)
Cut	Cut the currently select item and all its sub-items and copy them to the Windows clipboard. (The main icon cannot be deleted.)
Copy	Copy the currently selected item and all available sub-items to the Windows clipboard. (The main icon cannot be copied to the clipboard.)
Paste	Paste the contents of the clipboard at the currently selected location.

Section Menu. The Section menu (Table 3-16) allows you to navigate the sections of a table. Each table file can have up to 800 sections. The sections of a PMT correspond to programs. The sections of an NIT describe the physical organization of the multiplex (network). The sections of the SDT describe transport streams. The sections of a BAT describe a bouquet. The sections of the EIT each describe a service.

Table 3-16: Table editor Section menu commands

Use	To
Next	Display the next section.
Previous	Display the previous section.
Number	Display the entered section number.
New	Create a new section with the default values.
Insert	Insert a previously saved section (from the Open dialog box) into a table.
Delete	Delete the current section (without warning or recovery).

Time Span menu (PSIP Table Editor only). The PSIP EIT and ETT tables are split into three-hour time spans. The Time Span menu (Table 3-17) allows you to create, delete, and navigate time spans.

Table 3-17: Table editor Time Span menu commands

Use	To
Next	Display the next time span.
Previous	Display the previous time span.
Number	Display the entered time span.
New	Create a new time span with the default values.
Delete	Delete the current selection (without warning or recovery).

Analysis Menu. The Analysis menu (DVB and ATSC table editors only), shown in Table 3-18, allows you to check the integrity of selected table files.

Table 3-18: Table editor Analysis menu commands

Use	To
Consistency	Check the open table files for both internal and intra-table consistency with the standards.
Result Print	Send contents of message window to printer.

Option menu (PSIP Table Editor only). The Option menu (Table 3-19) commands let you switch between ASCII and Hexadecimal formats, and start an MGT wizard that automates creating a consistent (coherent) master guide table.

Table 3-19: PSIP table editor Option menu commands

Use	To
ASCII	Display information in ASCII format.
Print	Display information in hexadecimal format.
MGT Wizard	Start a wizard that automates creating a consistent MGT.

Help Menu. The Help menu (Table 3-20) provides standard Windows and application-specific information.

Table 3-20: Table editor Help menu commands

Use	To
Contents	Display the table editor online help contents.
Using Help	Display the <i>Using Windows Help</i> .
About...	Open the About window and discover version information for the Table Editor.

Command Buttons

The command buttons on the upper and lower toolbars act as shortcuts for several menu commands. Table 3-21 shows the toolbar command buttons and briefly describes their functions. Command buttons specific to a table editor are indicated. A blue dot on a tool type button indicates that a table file of that type is open in the table editor.

Table 3-21: Toolbar command buttons































Icon	Location	Function	Equivalent menu command
	Upper toolbar	Select, create, or open a PAT	File: Program Allocation Table
	Upper toolbar	Select, create, or open a PMT	File: Program Map Table
	Upper toolbar	Select, create, or open an EIT	File: Event Information Table
	Upper toolbar	Select, create, or open a CAT	File: Conditional Access Table
	Upper toolbar (DVB)	Select, create, or open an NIT	File: Network Information Table
	Upper toolbar (DVB)	Select, create, or open an SDT	File: Service Description Table
	Upper toolbar (DVB)	Select, create, or open a BAT	File: Bouquet Association Table
	Upper toolbar (DVB)	Select, create, or open an RST	File: Running Status Table
	Upper toolbar (DVB)	Select, create, or open a TOT	File: Time Offset Table
	Upper toolbar (DVB)	Select, create, or open a TSDT	File: Transport Stream Description Table
	Upper toolbar (PSIP)	Select, create, or open an MGT	File: Master Guide Table
	Upper toolbar (PSIP)	Select, create, or open a CVCT	File: Cable Virtual Channel Table
	Upper toolbar (PSIP)	Select, create, or open a TVCT	File: Terrestrial Virtual Channel Table
	Upper toolbar (PSIP)	Select, create, or open an RRT	File: Rating Region Table
	Upper toolbar (PSIP)	Select, create, or open an STT	File: System Time Table
	Upper toolbar (PSIP)	Select, create, or open an ETT	File: Extended Text Table
	Upper toolbar (ARIB)	Select, create, or open an SIT	File: Extended Text Table

Table 3-21: Toolbar command buttons (Cont.)

Icon	Location	Function	Equivalent menu command
	Upper toolbar (ARIB)	Select, create, or open a DIT	File: Extended Text Table
	Upper toolbar (ARIB)	Select, create, or open a BIT	File: Extended Text Table
	Upper toolbar (ARIB)	Select, create, or open a DCT	File: Extended Text Table
	Upper toolbar (ARIB)	Select, create, or open a DLT	File: Extended Text Table
	Upper toolbar (ARIB)	Select, create, or open an SDTT	File: Extended Text Table
	Upper toolbar	Add an item to the selection	Edit: Add
	Upper toolbar	Cut the selected item	Edit: Cut
	Upper toolbar	Analyze the table coherence	Analysis: Coherence
	Upper toolbar	Access the Global View	File: Global View
	Lower toolbar	View the previous section	Section: Previous
	Lower toolbar	View a specific section	Section: Number
	Lower toolbar	View the next section	Section: Next
	Lower toolbar (PSIP)	View the previous time span	Time Span: Previous
	Lower toolbar (PSIP)	View a specific time span	Time Span: Number
	Lower toolbar (PSIP)	View the next time span	Time Span: Next

NOTE. Although you can view and edit the contents of the PAT and CAT, you cannot export changes made to these files to the multiplexer. The PAT and CAT are created and updated dynamically by the multiplexer; PAT and CAT parameters can be edited for configuration files only from within the multiplexer.

Table Editor Icons

Table 3-22 lists all of the icons displayed by the table editors, what they represent, and where they are used in the table editors.

Table 3-22: Table editor icons













Icon	Represents
	Beginning of a Program Allocation Table Hierarchic view window of both the DVB and PSIP table editors
	Beginning of a Program Map Table Hierarchic view of both the DVB and PSIP table editors
	Beginning of a Conditional Access Table Hierarchic view of both the DVB and PSIP table editors
	Beginning of a Network Information Table Hierarchic and Global view windows of the DVB table editor
	Beginning of a Service Descriptor Table Hierarchic and Global view windows of the DVB table editor
	Beginning of Bouquet Association Table Hierarchic view window of the DVB table editor
	Beginning of an Event Information Table Hierarchic and Global view windows of both the DVB and PSIP table editors
	Beginning of a Running Status Table Hierarchic view window of the DVB table editor
	Beginning of a Transport Stream Description Table Hierarchic view window of the DVB table editor
	Beginning of a Time Offset Table Hierarchic view window of the DVB table editor
	Beginning of a Master Guide Table Hierarchic and Global view windows of the PSIP table editor
	Beginning of a Terrestrial Virtual Channel Table Hierarchic and Global view windows of the PSIP table editor
	Beginning of Cable Virtual Channel Table Hierarchic and Global view windows of the PSIP table editor

Table 3-22: Table editor icons (Cont.)

















Icon	Represents
	Beginning of System Time Table Hierarchic and Global view windows of the PSIP table editor
	Beginning of a Rating Region Table Hierarchic and Global view windows of the PSIP table editor
	Beginning of an Extended Text Table Hierarchic and Global view windows of the PSIP table editor
	Beginning of a Selection Information Table Hierarchic view window of the ARIB table editor
	Beginning of a Discontinuity Information Table Hierarchic view window of the ARIB table editor
	Beginning of a Broadcaster Information Table Hierarchic view window of the ARIB table editor
	Beginning of a Download Control Table Hierarchic view window of the ARIB table editor
	Beginning of a Download Table Hierarchic view window of the ARIB table editor
	Beginning of a Software Download Trigger Table Hierarchic view window of the ARIB table editor
	SIT service ID Hierarchic view window of the ARIB table editor
	BIT broadcaster ID Hierarchic view window of the ARIB table editor
	DCT transport stream ID Hierarchic view window of the ARIB table editor
	DCT maker and model ID Hierarchic view window of the ARIB table editor
	SDTT group ID Hierarchic view window of the ARIB table editor
	SDTT schedule Hierarchic view window of the ARIB table editor
	Beginning of a Title Multiple String Structure Hierarchic view window of the PSIP table editor

Table 3-22: Table editor icons (Cont.)











Icon	Represents
	Beginning of a Multiple String Structure Hierarchic view window of the PSIP table editor
	String of a Multiple String Structure Hierarchic view window of the PSIP table editor
	Segment of a Multiple String Structure Hierarchic view window of the PSIP table editor
	Rating Region Table Dimension Hierarchic view window of the PSIP table editor
	Rating Region Table Dimension Value Hierarchic view window of the PSIP table editor
	Program Hierarchic view window of both the DVB and PSIP table editors
	Table definition Hierarchic view window of the PSIP table editor
	Elementary Stream Hierarchic view window of both the DVB and PSIP table editors
	Transport Stream Hierarchic and Global view windows of both the DVB and PSIP table editors
	Channel Hierarchic and Global view windows of the PSIP table editor

Table 3-22: Table editor icons (Cont.)









Icon	Represents
	Service Hierarchic and Global view windows of the DVB table editor
	Event Hierarchic and Global view windows of both the DVB and PSIP table editors
	Descriptor Hierarchic view window of both the DVB and PSIP table editor
	Subdescriptor Hierarchic view window of both the DVB and PSIP table editor
	A television service Global view window of the DVB table editor
	Analog television Global view window of the PSIP table editor
	Digital television Global view window of the PSIP table editor
	A radio service Global view window of both the DVB and PSIP table editor
Txt	A teletext service Global view window of the DVB table editor
	Data broadcast Global view window of the PSIP table editor

Table File Operations

Table descriptions are contained in individual files. Only one table file of a given type can be open at a time.

Creating a New Table

Some tables, for instance the PAT, PMT, and NIT, are generated automatically and dynamically managed when you create a configuration file using the MTS300 MPEG-2 DVB / ATSC / ISDB-S Transport Stream Multiplexer. If you open these tables in a table editor from the multiplexer, many of the table elements and parameter values are completed for you. This is a very good way to create coherent tables for an existing set of programs and elementary streams in a multiplex. Other tables must be built from scratch or from a template.

To create a new table without using a template file, use the following procedure:

1. Click the **New** button on the Upper toolbar or select **New** from the File menu. The Table Type dialog box is displayed.

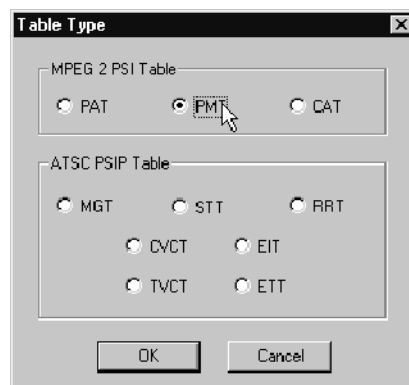

2. Click the option for the type of table you want to create, and then click **OK**.

NOTE. Although you can view and edit the contents of the PAT and CAT, you cannot export changes made to these files to the multiplexer. The PAT and CAT are created and updated dynamically by the multiplexer; PAT and CAT parameters can be edited for configuration files only from within the multiplexer.

If a table of the selected type is open, the table editor automatically closes it unless you have changed the table since it was last saved. If there are unsaved changes, the Save Table dialog box is displayed. Choose one of the following options:

- Save, to save the open table. (If the file is untitled, the Save as dialog box is displayed.)
- No, to close the current table file without saving the changes.
- Cancel, to quit the dialog box and return to the open table.

Opening an Existing Table

To open an existing table file, use the following procedure:

1. Select **Open** from the File menu. The Table Type dialog box is displayed.
2. Select the type of table you want to open, and then click **OK**. A standard Windows Open dialog box is displayed.
3. Navigate to and select the table file you want to open, and then click **OK**.

The selected file is displayed in the Hierarchy and Edit windows.

Saving Tables

The Save, Save As, and Close commands are functionally identical to the other Windows File menu commands. The table editors also have a Save All command that lets you save all open table files in one operation. The PSIP editor also has a Close all command that allows you to close all saved table files in one operation.

Save. The Save command saves the current table file. If the current table file is untitled, then the Save As dialog box is automatically displayed.

Save As. Choose the Save As command to save a table file under a new name. The Save As dialog box appears. Navigate to the appropriate directory and select or enter a new name in the File Name text box. The correct extension for the table type is added automatically to the file name.

NOTE. *The table editors require correct file name extensions. Do not use different extensions.*

Save All. The Save All command allows you to save all open table files at the same time. If any of the files are untitled, the Save As dialog box opens.

- Save, to save the open table. (If the file is untitled, the Save as dialog box is displayed.)
- No, to close the current table file without saving the changes.
- Cancel, to quit the dialog box and return to the open table.

After you name the file, the application continues saving the remaining files.

Close. The Close command closes the current table file window, but it does not close the application.

The Save Table dialog box appears if the table file has unsaved changes or if it is currently untitled. Choose one of the following:

- Save, to save the open table. (If the file is untitled, the Save as dialog box is displayed.)
- No, to close the current table file without saving the changes.
- Cancel, to quit the dialog box and return to the open table.

Close All (PSIP and ARIB editors only). The Close All command allows you to close all open table files at the same time. (The Close command closes the displayed file only.)

If any of the files are untitled or have unsaved changes, the Save Table dialog box opens. Make one of the following choices:

- Save, to save the open table. (If the file is untitled, the Save as dialog box is displayed.)
- No, to close the current table file without saving the changes.
- Cancel, to quit the dialog box and return to the open table.

After you save a file, the application continues closing the remaining files.

File Naming Constraints

There are special naming constraints for the PSIP EIT and ETT. These files are divided in multiple time spans, and the file name must be formatted consistently using the following method:

abc...111.exx

Where:

- abc... stands for the letters in the file name (usually the name of the configuration file used by the multiplexer).
- 111 stands for the time span index [000 – 127] for the EIT and [000 – 128] for the ETT. The value 128 is reserved for the channel ETT.
- exx stands for the appropriate file name extension for the EIT and ETT.

The following list illustrates the file naming constraints on the EIT and ETT. In these examples *test* indicates the name of a configuration file.

- *test000.eit* indicates an EIT file for time span zero
- *test012.eit* indicates an EIT file for time span twelve
- *test020.ett* indicates an ETT file for time span twenty
- *test0128.ett* indicates a channel ETT file

Selecting Among Open Tables

You can have one of each table type open simultaneously in the table editors. However you can display only one of the open tables at a time. To display an open table, click the command button that corresponds to the desired table type or select the type of table from the list of table types at the bottom of the File menu. The selected open table is displayed in the Hierarchic view window.

Creating an MGT Automatically

In ATSC environments, the MGT identifies all of the table types, table PIDs, version numbers, and table sizes for the VCT, EIT, ETT, RRT, and private tables in the multiplex. To automatically create an MGT based on the open table files in the PSIP Table Editor, use the following procedure:

1. Select **MGT Wizard** from the Options menu. The MGT Wizard dialog box is displayed.

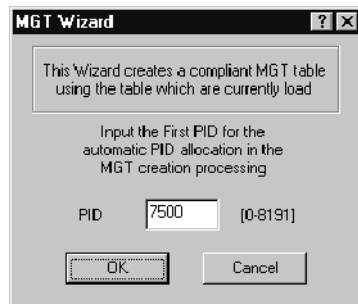

2. Click **OK** to use the PID values suggested by the wizard, or enter a new starting table item PID in the PID text box, and then click **OK**.

After you click OK, the wizard builds the appropriate MGT table items and correctly assigns the table type, PID, version, and size parameters for each table open in the table editor, except for the STT and RRT.

3. Save the MGT.

Table Sections

Most table files are composed of multiple sections: Depending on the table type, sections describe or correspond to different MPEG or network items:

- The sections of a PMT correspond to programs.
- The sections of the SDT describe transport streams, as do the sections of the TVCT and CVCT.
- The sections of a BAT describe a bouquet (or collection of services).
- The sections of the EIT each describe a service (DVB), or an event or collection of events for a virtual channel (ATSC).

Table 3-23 briefly describes what a section describes or corresponds to for each PSI, SI, and PSIP table type displayed by the table editors. It also lists how many sections each table file can have. (See the ISDB-S/ARIB standards documents for similar information for the ARIB tables.)

Table 3-23: Table sections

Table	Number of sections	Sections describe/respond to
PAT	1 to 256	A transport stream
PMT	1 to 20	A program
CAT	1 to 256	A conditional access system (or collection of systems)
NIT	1 to 256	The organization of the multiplex on a network
EIT	1 to 128 (at least four for ATSC environments)	A service (collection of events) (SI) or Events for a virtual channel defined in the VCT (PSIP)
BAT	1 to 256	A collection of services marketed together
SDT	1 to 256	Services for a specific transport stream ID
TSDT	1 to 256	A description of services carried on a specific transport stream
RST	1 to 256	A transport stream
TOT	Usually 1 ¹	A local time offset (relative to UTC)
MGT	Usually 1 ¹	The PSIP tables in the configuration file (except for the STT and RRT)
VCT	1 to 256	A transport stream
RRT	Usually 1 ¹	A rating region (systems are different by region)
STT	Usually 1 ¹	The UTC time reference
ETT	1 to 256	An extended text message describing a channel (channel ETT) or an event (event ETT)

¹ **These tables are usually transmitted as one section. However, multiple sections can be created and edited in the table editors.**

This rest of this section describes how to create and delete table file sections, and how to move among the sections of a table file.

NOTE. *Although you can view and edit the contents of the PAT and CAT, you cannot export changes made to these files to the multiplexer. PAT and CAT parameters can be edited for a configuration file only from within the multiplexer.*

Creating, Inserting, and Deleting Table Sections

Use the Section menu commands New, Insert, and Delete to add and delete table sections to the displayed table file.

New. Use the New menu selection to create a new table section.

Newly created sections become the last section in the displayed table, and the Hierarchical view changes to display the new, last section in the table. For example, if the current section is *Section 4 of 6 in the table*, and you then select New from the Section menu, the display will change to *Section 7 of 7 in the table*. The new section contains only the default information for that table type.

Insert. The Insert command adds an existing file, as a new section (or sections) to the end of a table. Use the following procedure:

1. Select **Insert** from the Section menu. The Open dialog box is displayed.
2. Navigate to and select the desired file, and then click **OK**.

Inserted table file sections are appended to the current table, and the display changes to show the last table section of the new file. For example, if the current section is *Section 4 of 6 in the table* and you insert a table file that has four sections, the display will change to *Section 10 of 10 in the table*. (The table file you selected to insert remains unchanged.)

Delete. The Delete command removes the currently displayed section. If the deleted section is a middle section, the sections that follow are re-numbered appropriately.



CAUTION. *Sections are deleted without confirmation. You cannot recover deleted sections.*

Moving Among Table Sections

Use the Section menu commands Next, Previous, and Number (and the command buttons on the Lower toolbar of the same name) to move among table sections. (Use the left-most set of command buttons for navigating table sections in the PSIP table editor.)

Next. Choose the Next command (or click the Next command button) to display the next section of the table file.

If the last section is currently displayed, you receive a message indicating that the current section is the last section in the table, and the application continues to display the current section.

Previous. To display the previous section of the current table file, select Previous from the Section menu (or click the Previous command button).

If the first section is currently displayed, you receive an error message indicating that the current section is the first section in the table, and the application continues to display the current section.

Number. Use the Number command button (or menu selection) to display a section of a table that is not within a few Next or Previous button clicks. To display a specific table section, click the Number command button (or select Number from the Section menu). The Section Number dialog box appears.

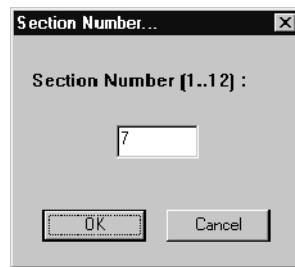

Enter the desired section number in the text box and click **OK**. If you enter a section number that is beyond the range, the last available section is displayed.

Creating, Deleting, and Moving Among Time Spans

In ATSC environments, EIT and ETT table files represent specific three-hour time spans. When these files are displayed, the Time Span menu selections are active. These menu selections are identical to those described for creating, deleting, and moving among table sections.

The command buttons for navigating time spans are the right-most set of buttons on the lower toolbar of the PSIP table editor. See the illustration on page 3-95.

Table Items

Often, table files are started from templates; for example, the table template files provided on the CD-ROM that ships with the Tektronix MTS300 MPEG Test System applications. However, to create the files you need to build transport streams with complex associations, you need to add table items to your table sections. This section describes the techniques you use to add and modify these items in the Hierarchic view.

The term *table items* refers any of the following table elements:

- Transport streams
- Programs
- Elementary streams
- Descriptors
- Events
- Services
- Titles
- Messages

Once added, icons appear in the Hierarchic view window that represent these items. To these items, you can often add other items.

For PSI, SI, and PSIP tables to be valid and coherent, you need to edit the table and item parameters in the Edit view window. The following sections provide the information you need about the specific fields and values for table items in order to create valid and coherent tables:

- *PSI and SI Table Item Parameters*, beginning on page 3-143
- *PSIP Table Item Parameters*, beginning on page 3-155

Adding Table Items

To add an item to a table section, use the following procedure:

1. Select the Hierarchic view icon to which you want to add a table item.
2. Select **Add** from the Edit menu, or click the + command button on the upper tool bar.

If there is only one appropriate type of item, that item is automatically added. Otherwise, the Add dialog box shown in the following illustration is displayed. This dialog box allows you to specify the type of item to add.

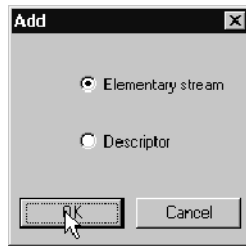

Available items listed in the Add dialog box depend on the table type and insertion point. Table 3-24 on page 3-118 describes the choices available at the table icon level.

3. If the Add dialog box is displayed, select the appropriate option, and then click **OK**. The item selected will be added to the table hierarchy. Click **Cancel** at any time to close the dialog box without making changes to the hierarchy.

If you are adding a descriptor, the Descriptors Selection dialog box is displayed. This dialog box is represented by the following illustration.

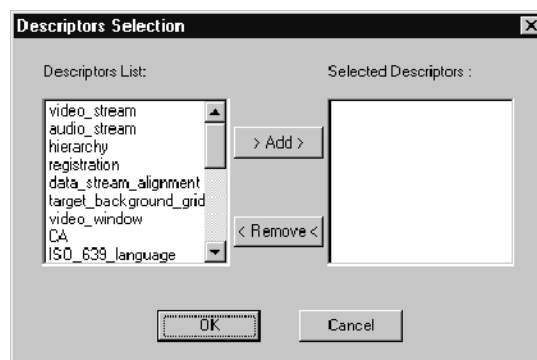

See *Adding Descriptors* on page 3-122 for more information about adding descriptors to tables and table items.

Table 3-24: Items added to table sections

Selected icon	Items that can be added
PAT	Programs
PMT	An elementary stream or a descriptor
NIT	A transport stream or a descriptor
BAT	A transport stream or a descriptor
SDT	A service
EIT	An event (DVB) or a time span (PSIP)
RST	An event
TOT	A local time descriptor
TSDT	A descriptor
VCT	A channel or a descriptor
MGT	A table or a descriptor
RRT	A dimension, rating region name, or descriptor
ETT	A message
STT	A descriptor
CAT	A conditional access system
SIT	A service or a descriptor
DIT	-----
BIT	A broadcaster or descriptor
DCT	A transport stream
DLT	-----
SDTT	An SDTT group

NOTE. Although you can view and edit the contents of the PAT and CAT, you cannot export changes made to these files to the multiplexer. The PAT and CAT are created and updated dynamically by the multiplexer; PAT and CAT parameters can be edited for configuration files only from within the multiplexer.

You can add items listed in Table 3-25 at the stream, event, or service level.

Table 3-25: Items added to other table items

Icon	Items
Transport stream	Another transport stream or a descriptor
Program	Another program
Elementary stream	Another elementary stream or a descriptor
Channel	Another channel or a descriptor
Table	Another table or a descriptor
Service	Another service or a descriptor
Event (EIT)	Another event or a descriptor
Event (RST)	Another event
Message/Title/Name	A string
String	A segment
Segment	Another segment
Dimension (RRT)	A dimension name or a value
Broadcaster (BIT)	A descriptor
SDTT group	SDTT schedule
Descriptor and Sub-Descriptor	Other descriptors, sub-descriptors, and/or sub-sub-descriptors

When you add an item to an icon that does not represent the beginning of a table, the item icon is added “in parallel” to the existing item. When you add a descriptor, the descriptor icon is added to the right of the item.

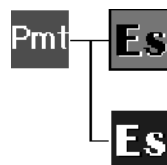

Stream selected,
stream added



Stream selected,
descriptor added

At the descriptor level, you can add another (parallel) descriptor. You can also add a subdescriptor to some descriptor types (refer to *PSI, DVB SI, and ATSC PSIP Table Item Parameters*, beginning on page 3-143).

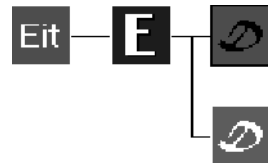

Descriptor selected, descriptor added



Descriptor selected, subdescriptor added

At the subdescriptor level, you can add another parallel subdescriptor. In certain cases, you can also add a sub-subdescriptor.



Subdescriptor selected, subdescriptor added



Subdescriptor selected, sub-subdescriptor added

Adding a Stream, Service, or Event

When you add a transport stream, service, event, or conditional access to a table, the icon is placed immediately in the hierarchy. When you choose to add an elementary stream to a PMT, the following warning window appears.

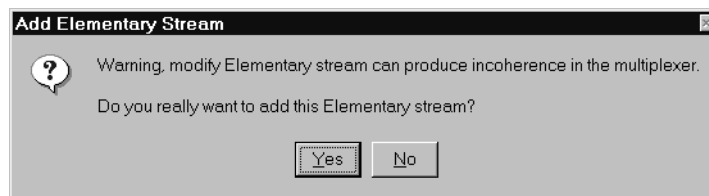

NOTE. Because it is likely to produce incoherence in the configuration file and between tables, do not add or delete elementary streams when you start the table editor from the *MTS300 MPEG-2 DVB / ATSC / ISDB-S Transport Stream Multiplexer*.

After you add a new item, select the icon and enter the appropriate values in the Edit window text boxes (to the right of the Hierarchic view window).

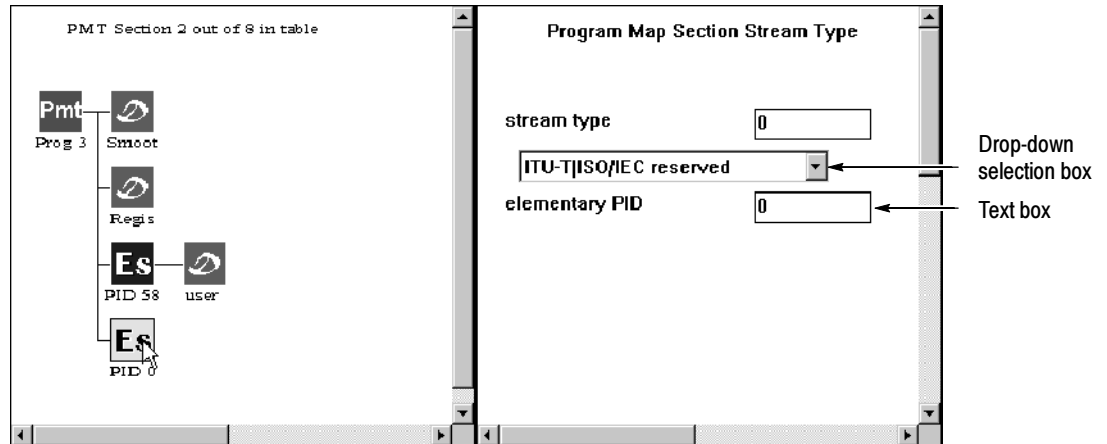

There are two types of Edit view fields you can modify: drop-down selection boxes and text boxes.

Drop-down selection boxes allow you to select from a list of options available when you click the ▼ button to the right of the drop-down box. After you make your selection, the text field immediately above it automatically changes to the appropriate value.

Text boxes take alpha-numeric characters. In the PSIP Table Editor you can toggle the input format for some parameters between ASCII and hexadecimal (select the appropriate option from the Options menu).

See the following sections for more information about the various stream, service, and event parameters.

- *PSI, DVB SI, and ATSC PSIP Table Item Parameters*, beginning on page 3-143
- *PSIP Table Item Parameters*, beginning on page 3-155

Adding Descriptors

Use the following procedure to add descriptors to a table item:

1. Select a **Descriptor** in an Add dialog box, and then click **OK**. The Descriptors Selection dialog box is displayed.

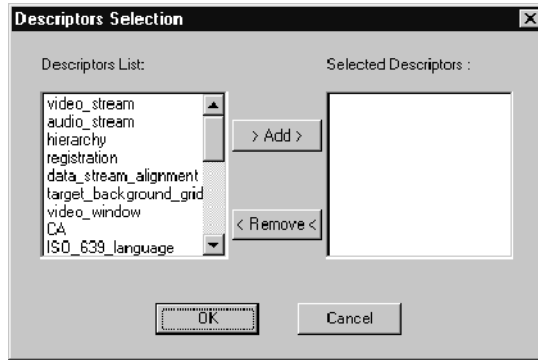

2. Select the type of descriptor you want to add from the List of Descriptors drop-down selection box.
3. Click **Add**. The descriptor name appears in the Descriptors Selected list.
4. Repeat steps 2 and 3 until the Descriptors Selected field lists all the descriptors you want to add to the selected table item.

In the PSIP Table Editor, you can select multiple descriptors using the *Shift* and *Control* keys.

5. Click **OK** to add the selected descriptors to the table and hierarchy. Click **Cancel** to close the dialog box without adding any descriptors.

6. Select the descriptor icons one at a time and enter the appropriate information in the Edit window text boxes.

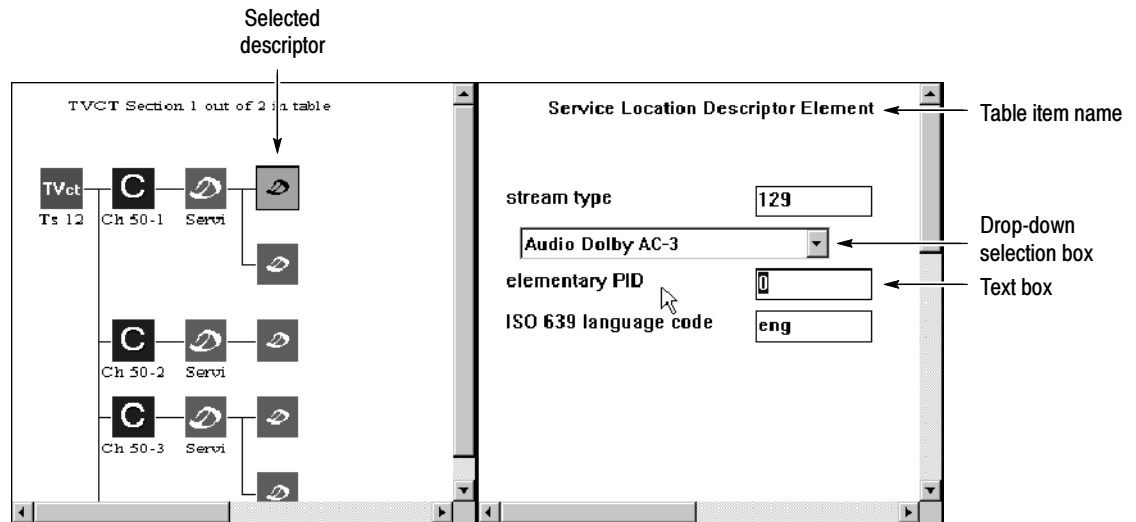

There are two types of Edit view fields you can modify: drop-down selection boxes and text boxes.

Drop-down selection boxes allow you to select from a list of options available when you click the ▼ button to the right of the drop-down box. After you make your selection, the text field immediately above it automatically changes to the appropriate value.

Text boxes take alpha-numeric characters. In the PSIP Table Editor you can toggle the input format for some parameters between ASCII and hexadecimal (select the appropriate option from the Options menu).

See the following sections for more information about the descriptor parameters.

- *PSI, DVB SI, and ATSC PSIP Table Item Parameters*, beginning on page 3-143
- *PSIP Table Item Parameters*, beginning on page 3-155

Removing, Copying, and Pasting Table Items

Use the Delete, Cut, Copy, and Paste commands of the Edit menu to edit table sections.

Delete. The Delete command (**Del** key) removes the selected item and any items below it in the hierarchy display. The icons that represent the file type cannot be deleted. The delete command does not place removed items onto the clipboard.

Cut. The Cut command (**CTRL-x**) is identical to the Delete command except that cut items are placed on the clipboard. They can then be pasted back in the table file at the same or a different location.

Copy. The Copy command (**CTRL-c**) copies the currently selected item to the clipboard. It is then available to paste at different locations. All items below the selected item on the hierarchy are also copied to the clipboard.

NOTE. *To copy the entire table, use the File menu Save As command and save the table file under a different name.*

Paste. The paste command (**CTRL-v**) adds the contents of the clipboard to the selected icon in the table file. If the top-level item being pasted is at the same level as the selected icon, the item(s) are inserted immediately below the selected icon.

**Searching for Table Items
(Find)**

This command is part of the DVB Table Editor Edit menu. Use it to search for section-specific information in a table.

1. In an open section, select **Find** from the Edit menu. A Find dialog box appears.
2. Complete the requested section information and click **OK**.

The Find dialog box contents vary depending on the type of section you are searching.

**Learning More About PSI,
SI, PSIP, and ISDB-S/ARIB
Table Items**

PSI tables are defined in the ISO/IEC 13818-1 international standard. This standard is included in the Tektronix MTS300 MPEG Test System as a Windows help file. To open the file, double-click the MPEG-2 Help icon in the Tektronix MPEG Test System program group window.

You can also refer to ISO/IEC 13818-2 for additional information about video encoding or ISO/IEC 13818-3 for information about audio encoding. These publications are available through the ISO (International Organization for Standardization).

SI tables and descriptors are defined in ETS 300 468. PSIP tables and descriptors are defined in ATSC Document A/65. Use these documents to learn more about tables and descriptors for DVB and ATSC environments.

Refer to the following ARIB (Association of Radio Industries and Business) and ITU-R (International Telecommunications Union) standards for more information about ISDB-S and ARIB transport stream elements:

- ARIB STD-B10 (1.2), 1999, *Service Information for Digital Broadcasting System*
- ARIB STD-B16 (1.1), 1999, *Digital Receiver Commonly Used for Digital Satellite Broadcasting Services Using Communication Satellite*
- ARIB STD-B20 (1.1), *Digital Broadcasting System and Related Operational Guidelines for Broadcasting Satellites*
- ITU-R BO. 1408, *Transmission System for Advanced Multimedia Services Provided by Integrated Services Digital Broadcasting in A Broadcasting Satellite Channel,*

Table Analysis

Using the DVB and ATSC table editors, you can easily check the open tables for conformance to the relevant standard. During an analysis, the table editors check all open table files for consistency/coherence both within a table file (called intra-analyses) and between the open table files (called inter-analyses).

NOTE. *The information in this section does not apply to the ARIB Table Editor.*

This section provides the following information:

- *Performing Consistency/Coherence Analyses* (this page)
- *Using the Error Message Window* (page 3-128)
- *Interpreting Error Messages* (page 3-130)

Performing Table Analyses

The table editors use slightly different terminology for the analyses performed, but they both perform similar functions:

- In the MTS300 PSIP Table Editor, the menu selection that initiates an analysis is *Consistency* from the Analysis menu.
- In the MTS300 DVB Table Editor, the menu selection that initiates an analysis is *Coherence* from the Analysis menu.

The procedure for performing an analysis is slightly different for the DVB and PSIP table editors. To perform an analysis on all open tables using the PSIP table editor, use the following procedure; to perform an analysis using the DVB table editor, skip steps 3 and 4.

1. Save all open tables by selecting **Save All** from the File menu (see *Save All* on page 3-110).

- Click **A** on the Upper toolbar, or select **Consistency** from the Analysis menu (for the DVB table editor, select **Coherence**). The Analysis Parameters dialog box is displayed.

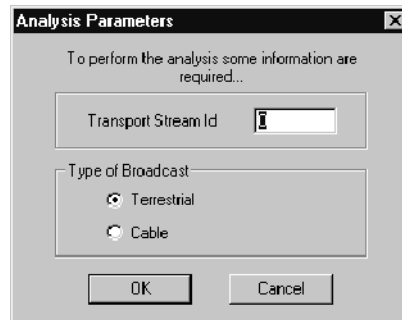

- Enter the transport stream ID for the tables you want to analyze in the Transport Stream ID text box. If you do not know the value of the transport stream ID, leave it at zero.
- Select either the Terrestrial or Cable option in the Types of Broadcast group, and then click **OK** to close the dialog box and begin the analyses. Click **Cancel** to close the dialog box without performing any analyses.

After you click OK, the message window is displayed, showing the error messages resulting from both the intra-analyses (within table file analyses) and inter-analyses (between table files analyses). The last inter-analysis error message is highlighted.

You can resize and position the message window as necessary to make the error messages easier to read.

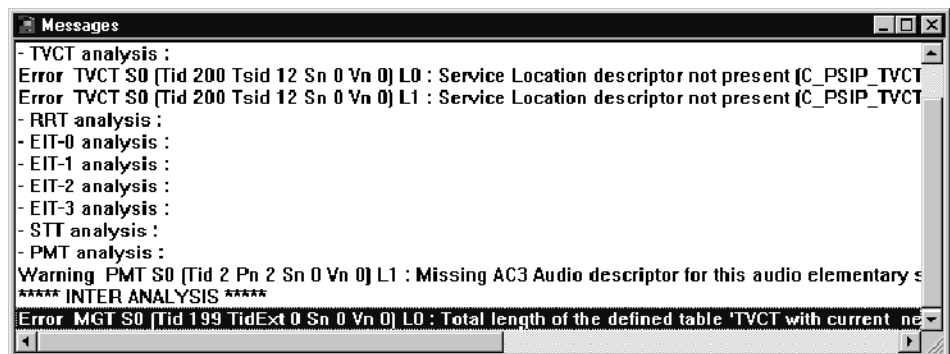

Intra-analyses are performed first, and, if the analyses generates many messages, you may need to scroll up in the message window to see the beginning of the intra-analyses messages.

NOTE. *The PSIP Table Editor does not check the program paradigm and service location descriptors within the VCT.*

Using the Error Message Window

The error message window lists errors and warnings that result from performing table analyses on the open tables in the table editor. This message window is interactive and allows you to display the nonconforming table item directly from the Message window. Use the following procedure to display the table file and item with the indicated error:

1. Perform an analysis on the open tables in the table editor. (See *Performing Table Analyses* on page 3-126.)
2. If the analysis reports any errors, double-click on an error listed in the message window.

The table and item (such as a stream, event, service, or descriptor) that contains the error is displayed in the Hierarchic and Edit view windows.

The hierarchy of the appropriate table section appears in the Hierarchy window with the nonconforming table or table item highlighted. For instance, in the following illustration the AC-3 audio descriptor needs to be

added to the elementary stream, and the relevant icon is highlighted in the Hierarchic view.

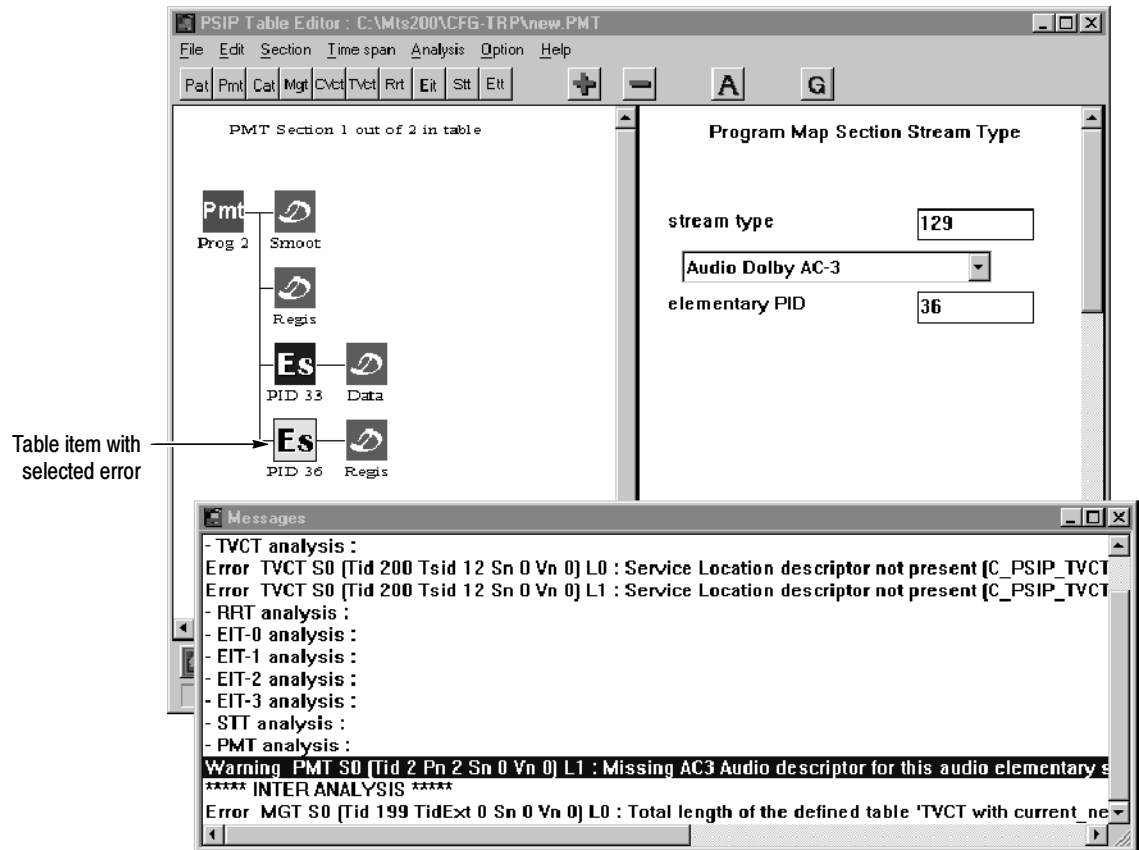

3. Correct the error(s) by adding the indicated table item or editing the parameter value in the Edit window, and then rerun the analysis to check the corrections. Often, correcting one value removes multiple error messages from the Message window.

You may need to scroll up or down in the Edit view window to locate the parameter name and text box in order to edit it.

You can print the contents of the message window by selecting **Print** from the Analysis menu. Use the resulting Print dialog box to select the printer and print the error messages.

Interpreting Error Messages

The error messages displayed in the Message window have certain characteristics that will help you locate the item in error and correct the problem. These characteristics are shown in the following illustration.

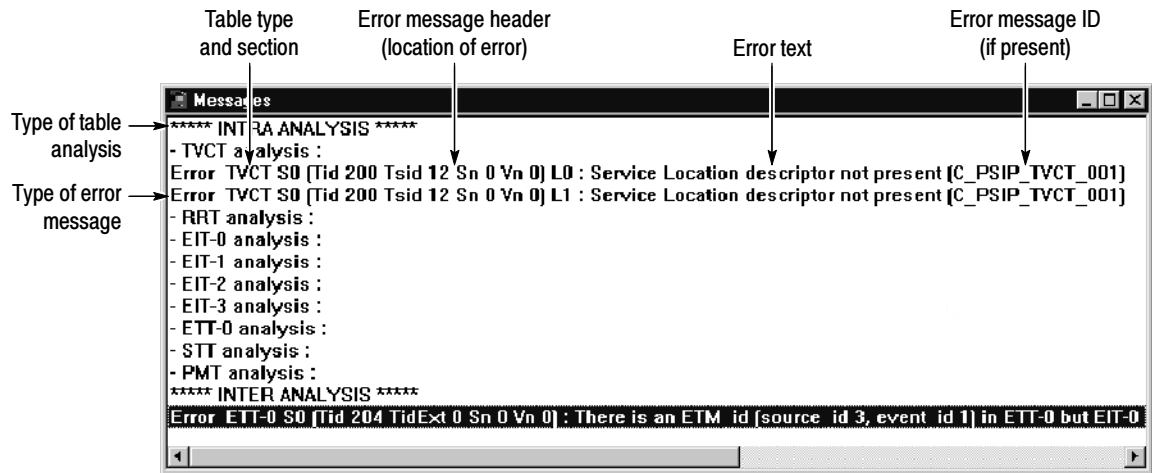

Table Analysis Types. The table editors perform the following types of analyses on all of the open table files in the table editor:

- Intra-analyses check each open table file value and structure for coherence to the appropriate standard. For example, when required AC-3 descriptor is not found in a section of the PMT, the error is an intra-analysis error.
- Inter-analyses check the open table files for consistency between table files. For example, if an MGT defines the length of an EIT-0 table that is different from the actual length of the table, the error is an inter-analysis error.

Type of Error Message, Table Type, and Section. The first part of an error lists the type of error reported on that line. The table editors report two types of errors. The differences relate to the different error levels of ETR 290:

- Error messages relate to level one and two errors. The DVB Table Editor reports only one error per analysis (it stops upon encountering an error).
- Warning messages relate to level three errors.

Immediately following the type of error is the table type and the table section in which the error is found.

Error Message Headers. The error message header identifies the location of the error. Each header uses a prefix described in Table 3-26 to identify a table, item, or section. The text following the prefix uniquely identifies that part of the table item with an error.

Table 3-26: Table editor error prefixes

Prefix ¹	Meaning
S%	Section number (outside of the square brackets)
L%	Loop number in section
FDL	First descriptor loop
D%	Descriptor number in loop
Nid%	The network_id parameter
Tid%	The table_id parameter
Tsid%	The transport_stream_id parameter
Sid%	The service_id parameter
Onid%	The original_network_id parameter
Eid%	The event_id parameter
Bid%	The bouquet_id parameter
Pn%	The program_number parameter
Sn%	The section_number parameter
Vn%	The version_number parameter

¹ **Numeric values replace the % in the error messages**

Error text. The text of the error messages provide some clue as to the reason for the error, and often the solution is obvious. However, when you need more information on a specific error message, use the online help to access the topic that corresponds to the error message. (See *Online Help for the PSIP Table Editor Error Messages* and *Online Help for the DVB Table Editor Error Messages* on page 3-131.)

Error Message IDs. The PSIP Table Editor also uses an error message ID that will help you locate a specific error message description in the online help. See *PSIP Table Editor error message online help* below to learn how to use this message ID.

Online Help for the PSIP Table Editor Error Messages. Use the following procedure to display online help for PSIP Table Editor error messages:

1. Scroll the error message window to the right and note the error message ID. (The error message ID will look similar to [A_PSI_PRPA_001].)

2. Select **Contents** from the Help menu.
3. From the Contents tab, double-click the **Consistency analysis** book, and then open the **Analysis messages** book. The books are organized by type of message, which relate to the first letter in the error message ID as indicated in the following list:
 - **A.** *Messages about the constraints on MPEG2*
 - **B.** *Messages about the PSIP requirements*
 - **C.** *Messages about the PSIP constraints*
 - **D.** *Messages about the compliance between PSIP and MPEG2*The last book, *General messages*, provides descriptions and possible solutions for error messages without error message IDs.
4. Open the appropriate book, and then select the appropriate error message ID. Error message IDs are organized alpha-numerically in each book.

Online Help for the DVB Table Editor Error Messages. The DVB Table Editor analysis messages are displayed in the format header : message. Also, two types of messages are displayed in the DVB Table Editor message window: Warnings and Errors. The analysis stops when an Error is encountered. Use the following procedure to display online help for Warning and Error messages in the DVB Table Editor.

1. Select **Contents** from the Help menu.
2. From the Contents tab, double-click the *DVB SI & PSI Table Editor* book, and then the *Table editor functionalities*.
3. Open the *Analysis messages* book and then select the topic related to the type of error message listed in the Message window: Error or Warning.

Global View

The Global View window is a separate window that shows the association between selected SI and PSIP table files. Not all open table files are represented in the Global view window. You can use the Global view window for the following purposes:

- To visualize the associations among the transport streams, services, and events described in the managed table files (the NIT, SDT, and EIT for MPEG-2 and DVB environments and the VCT, EIT, and ETT table files for the ATSC environment).

- To move among tables and from one table element to another. This can be especially useful when you are trying to create a set of tables with complex associations.
- To open specified files in order to perform coherence analyses on the interrelated parts of MPEG-2, DVB, and ATSC table files.

NOTE. *The information in this section does not apply to the ARIB Table Editor.*

Opening the Global View Window

One way to display table files is to open the following Global View window and specify the table files you want to open during the procedure. This technique allows you to open multiple table files at once, and display them in both the Global and Hierarchic view windows.



CAUTION. *Opening files using the Global view will close any open table files of the same type without giving you a chance to save those files. Make sure you save all open files before using this technique.*

1. Save any open files in table editor.
2. Select **Global view** from the File menu, or click **G** on the upper toolbar.
3. If you are using the PSIP table editor, the VCT File Selection dialog box is displayed, which allows you to specify the VCT type you want to open (cable or terrestrial). Select the appropriate environment, and then click **OK**.



4. The Global View File Selection dialog box is displayed, which is shown in the following illustration using the PSIP table editor. (Currently open table file names appear in text boxes).

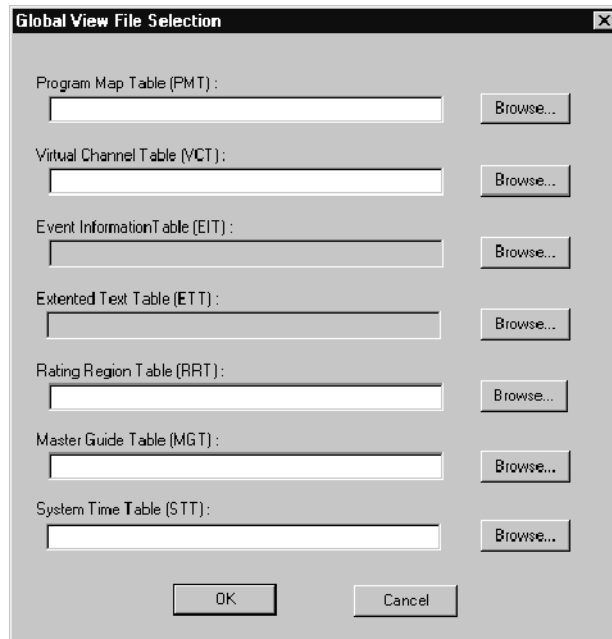

5. If a table you want to display is not named in the table type text box, click **Browse**.
6. For PSIP EITs and ETTs, a dialog box is displayed allowing you to choose to open all time spans or only a specific time span. Make the appropriate selection, and then click **OK**.

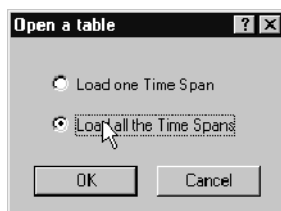

A standard Windows NT Open dialog box is displayed. Select the table file you want to open.

7. Click **OK** to close the Global View File Selection dialog box. The Global view window is displayed with the selected table files open in the both the Hierarchic and Global view windows.

Collapsing and Expanding Tables in the Global View

When the Global view window first opens, the hierarchy of each displayed table is fully expanded and all of the table elements are displayed, as shown in the following illustration using the PSIP table editor.

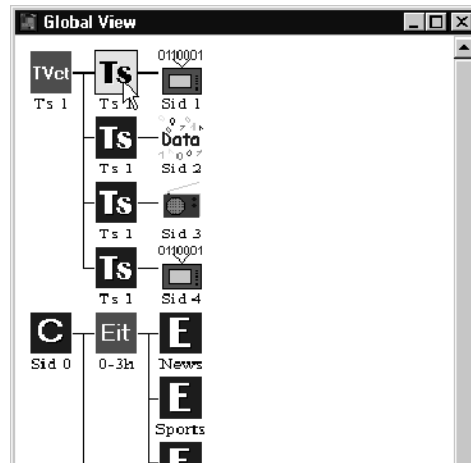

To collapse any part of a table hierarchy, double-click on an icon at the point below which you want to hide table elements. For instance, to collapse the service icons (SID icons) in the previous illustration, double-click a TS icon.

In the following illustration, all of the service icons except SID 4 have been collapsed. Note the slight shadow behind the icons. This indicates that other table elements are hidden behind that table element.

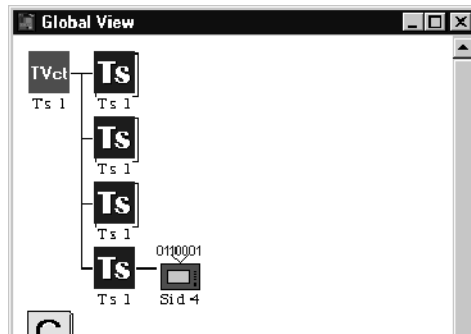

To expand a table, double-click on the icon at which the hierarchy is collapsed.

Using the PSIP Table Editor Global View Window

In the ATSC environment, transport streams, channels, and events are managed using the VCT and EIT. In the following example, the ETT files are included to show how extended text messages are associated with events occurring on the transport stream. When you use the Global view for the purposes of specifying these relationships, you need to open only the VCT, EIT, and ETT. You can select other PSIP files when you want to open all of the files at once, for instance, when you want to perform coherence analyses on a set of PSIP table files.

VCT and EIT tables can show no association or a very high degree of association, as depicted in the following illustration.

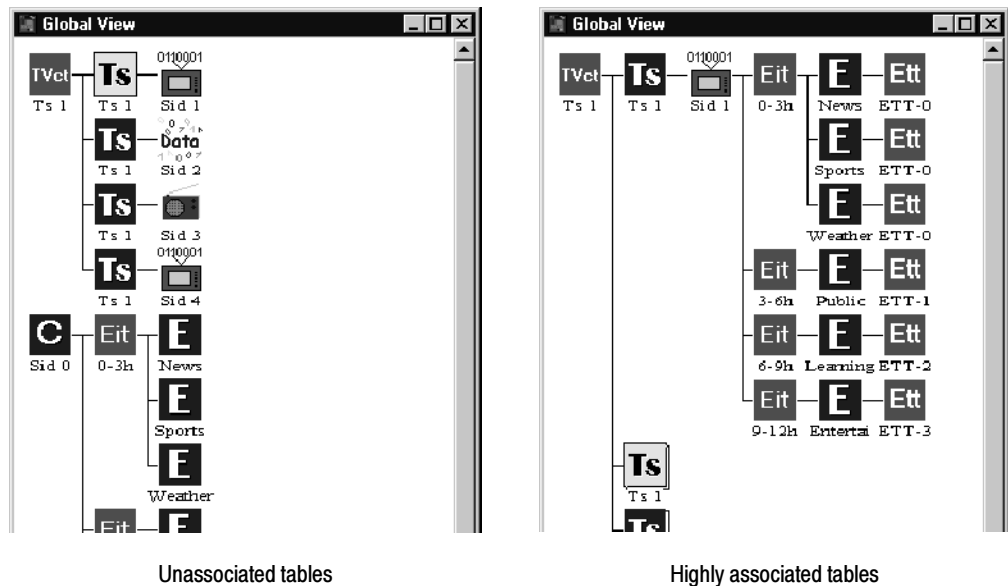

Channels, events, and Extended Text Messages (ETMs) are managed using the following VCT, EIT, and ETT values:

- Source IDs, which are specified in the channel element of the VCT and in the EIT.
- Event IDs, which are specified in the event element of the EIT.
- ETM IDs which are specified in the ETT and define the specific event in the transport stream to which an Extended Text Message (ETM) applies. (See page 3-138 for more information about ETM ID values.)

The following three illustrations depict these relationships. In the first illustration, the transport stream and channels in the VCT are defined. However, the source IDs in the events of the EITs are not the same as the source IDs in the channel elements of the VCT. Also, the event IDs and ETM IDs are not defined.

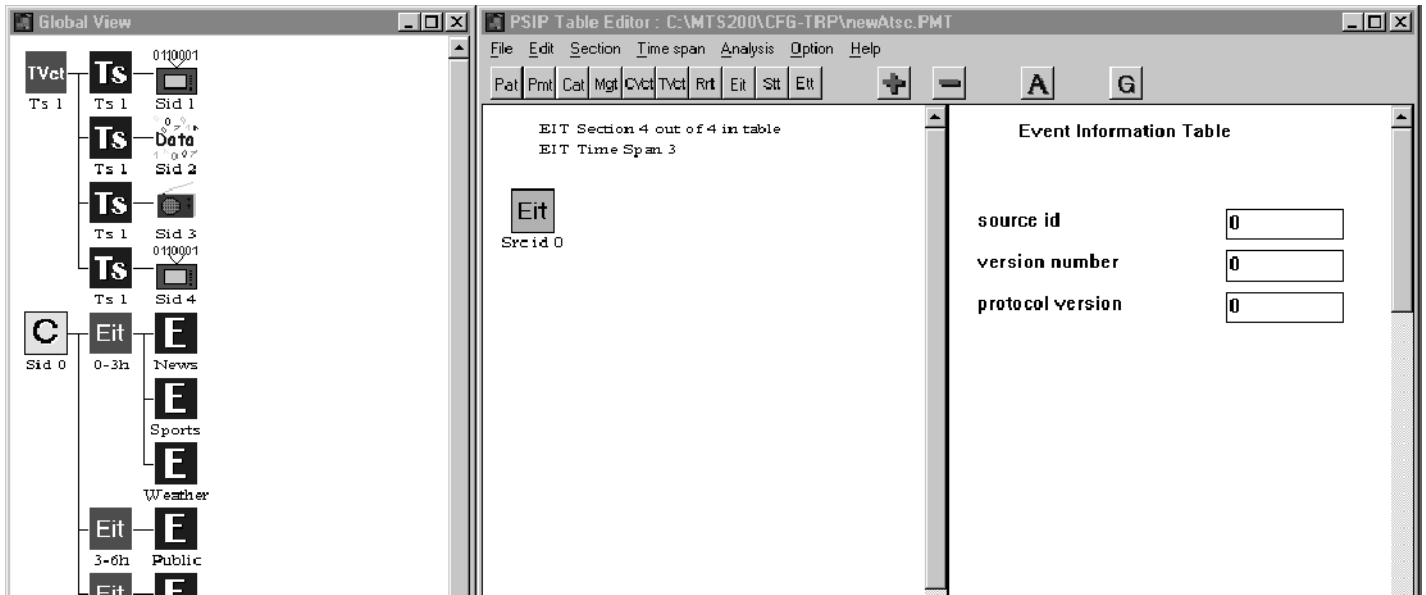

In the next illustration, the source ID in the four EIT time spans have been updated correctly for the first channel in the VCT, SID 1. Consequently, the first EIT time span is now associated with the channels described in the VCT. However, the remaining sections of the EITs and the ETM IDs have not been updated.

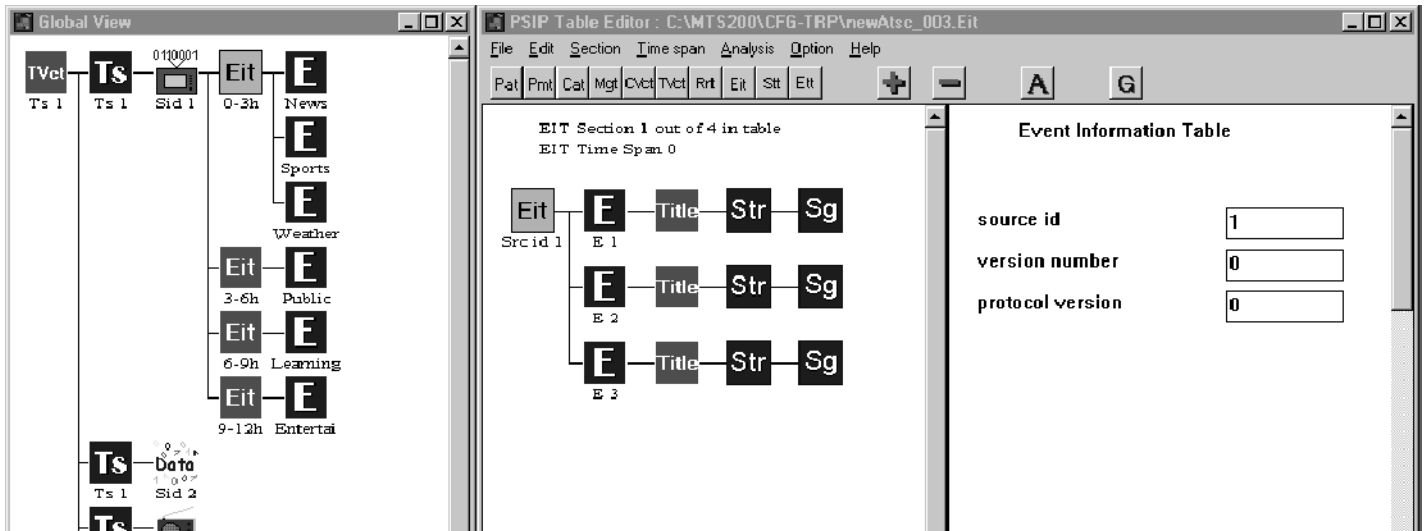

In the next illustration, the source IDs in all EIT time spans have been updated correctly, as have the ETM ID values for all of the events described for SID 1.

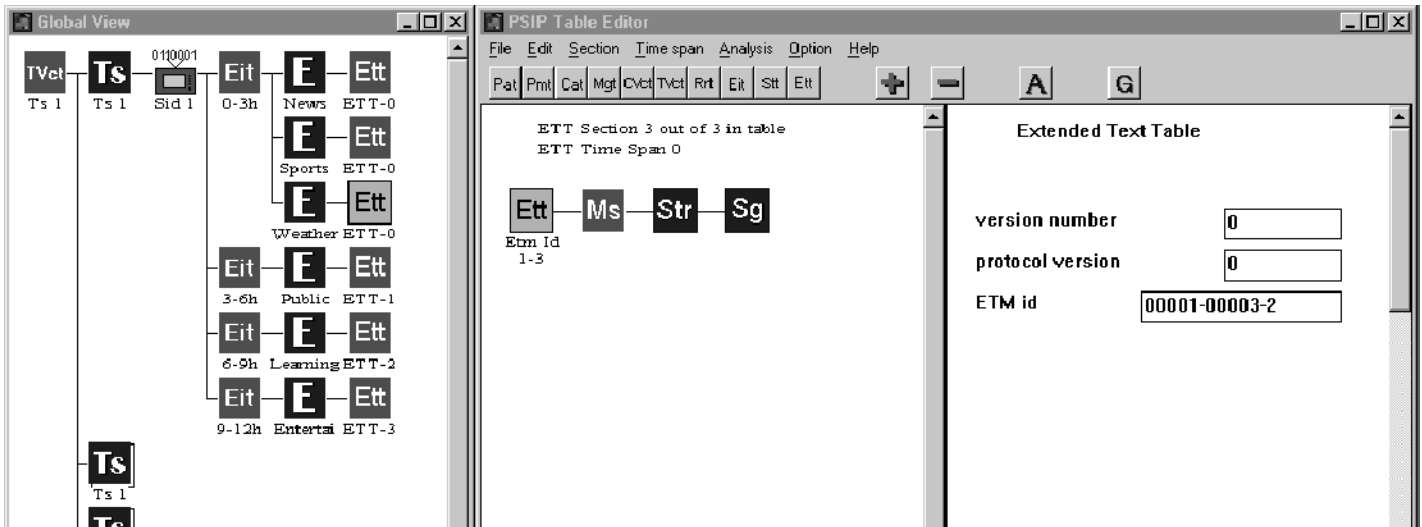

The ETM ID value in extended text tables specifies the event to which the extended text message belongs. The following list describes how the ETM ID value specifies the relationship:

NOTE. In order for an Extended Text Message (ETM) to be associated with an event described in an EIT, the time span for the ETT must be the same as the time span for the EIT.

- The first five places in the ETM ID text box define the source ID of the event to which the extended text message applies.
- The middle five places in the ETM ID text box define the specific event (defined in the EIT) to which the extended text message applies. For channel ETMs, the middle five places are 00000 (the message applies to a channel rather than an event).
- The last digit in the ETM ID field indicates whether the message is an event, in which case the value is two (2), or a channel message, in which case the value is zero (0).

Using this information, the ETM ID value shown above indicates that the message applies to the third event in the EIT-0 instance of SID 1.

Using the DVB Table Editor Global View Window

Tables displayed in the Global view can exhibit no association or a high degree of association, as shown in the following illustration.

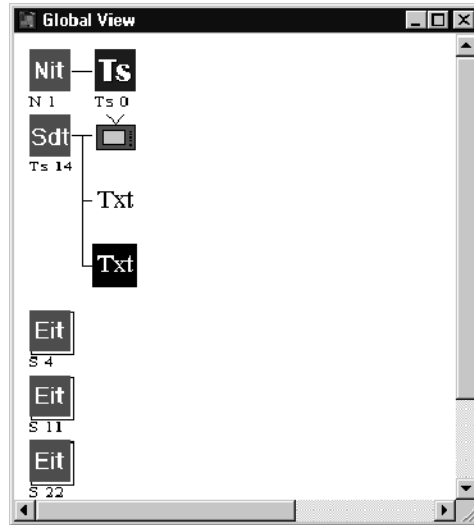

Unassociated tables

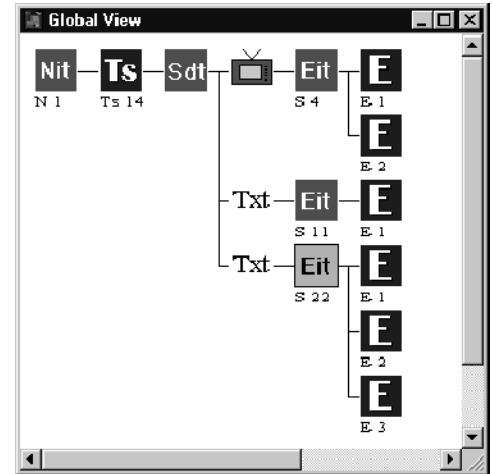

Highly associated tables

In the DVB and MPEG-2 environments, the following mechanisms are used to manage the programs or events that occur in the transport stream:

- The transport stream ID, which is specified in the transport stream element of the NIT and in the SDT.
- The service ID, which is specified in the service element of the SDT and in the EIT.
- The event ID, which is specified in the event element of the EIT.

The event element specifies the start time, status, and duration of one specific event occurring in a transport stream.

The following four illustrations depict how these elements manage services and events that occur on a given transport stream. In the first illustration, the table files are not associated with each other.

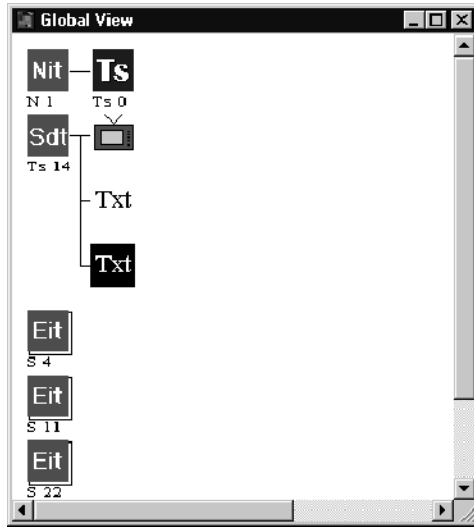

In the next illustration, the transport stream ID value in the SDT has been updated to that of the transport stream defined in the NIT. In the Global view, the NIT and SDT depict the transport stream ID identity they share.

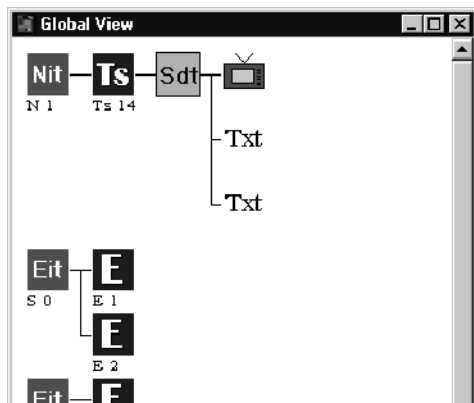

In the next illustration, the service IDs in the three sections of the EIT have been updated to that of the three services described in the SDT. However, only the first two sections of the EIT have the correct transport stream ID value.

Consequently, the third section of the EIT is not associated with any service defined in the transport stream.

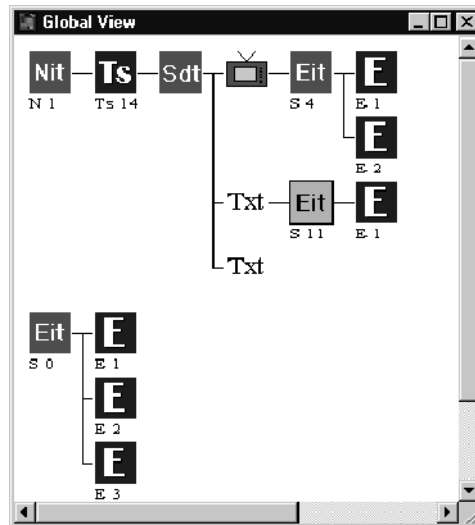

In the last illustration, all of the transport stream IDs and service IDs are updated:

- The transport stream ID values in the NIT, SDT, and EIT are identical
- The service ID values in the SDT and the EIT are identical

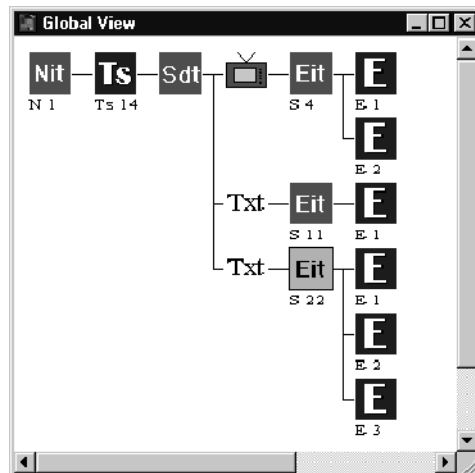

In this example, the three services described in the SDT have service descriptors that indicate the type of service carried in the transport stream. Also, the EIT sections each describe specific events.

PSI, DVB SI, and ATSC PSIP Table Item Parameters

Editing a table involves entering the appropriate information and parameter values for each table section, elementary stream, descriptor, and sub-descriptor. For example, an TVCT channel must have the appropriate channel transport stream ID and program number if it is to be correctly associated to a program in the transport stream.

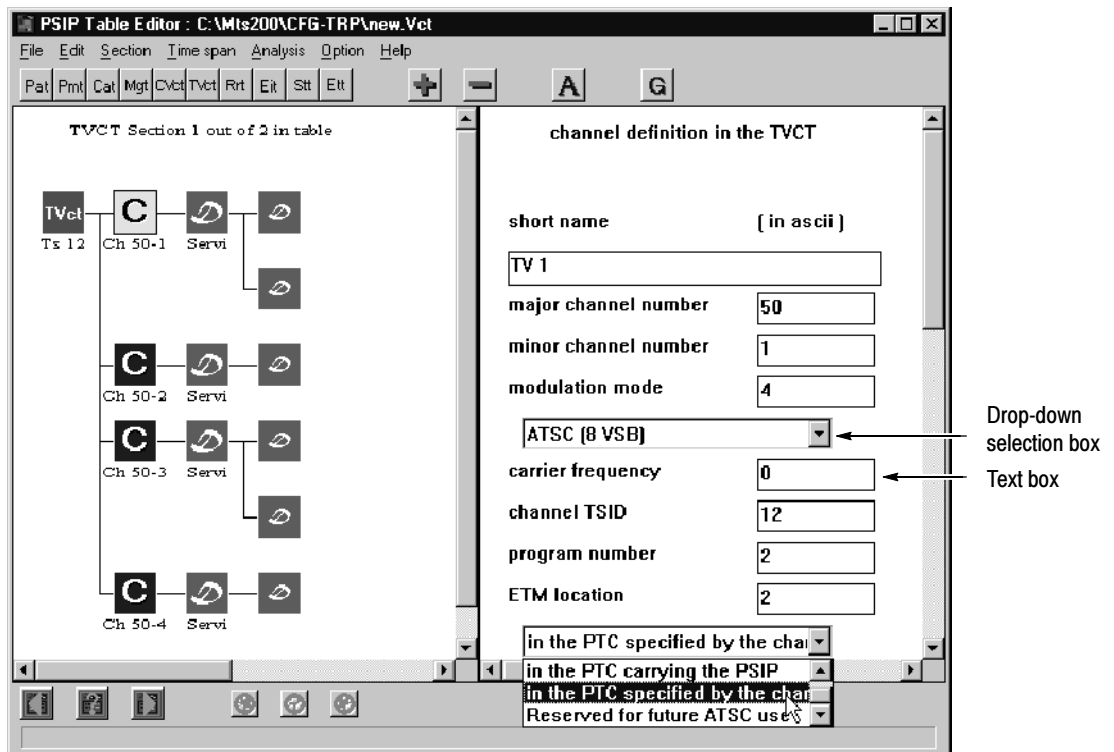

There are two types of Edit view fields you can modify: drop-down selection boxes and text boxes. In each case, click in the Hierarchic view window to apply the changes made in the Edit window.

Drop-down selection boxes allow you to select from a list of options available when you click the ▼ button to the right of the drop-down box. After you make your selection, the text field immediately above it changes to the appropriate value.

Text boxes take alpha-numeric characters. In the PSIP Table Editor you can toggle the input format for some parameters between ASCII and hexadecimal (select the appropriate option from the Options menu).

This remainder of this section describes the fields and parameters of each table and table item displayed in the table editors. In most cases, a range of possible values is provided for each parameter. Other PSI, SI, and PSIP parameters are either fixed or determined automatically by the table editors. For more information about table items, refer to *Learning More About PSI, SI, and PSIP Table Items*, on page 3-125.

PSI and SI Table Parameters

You can specify the parameters of the following ten PSI and SI tables using the MTS300 DVB Table Editor:

- BAT
- CAT
- EIT
- PAT
- PMT
- NIT
- RST
- SDT
- TOT
- TSMT

This section describes the parameters for these tables, with the exception of the PAT. See *PSIP Table Parameters* on page 3-155 for similar information about PSIP table fields and parameters. See pages 3-163, 3-169, and 3-185 for similar information about PSI, SI, and PSIP descriptor parameters respectively.

NOTE. *Although you can view and edit the contents of the PAT and CAT, you cannot export changes made to these files to the multiplexer. The PAT and CAT are created and updated dynamically by the multiplexer; PAT and CAT parameters can be edited for configuration files only from within the multiplexer.*

BAT The Bouquet Association Table groups possible services used by the decoder to present available services to the viewer. A particular service can belong to one or more bouquets.

BAT parameter	Possible values	Notes
Bouquet ID	0 to 65535	ETSI publication ETR 162 lists valid IDs for various bouquets.
Version number	0 to 31	Incremented by 1 when the information contained in the table section changes.
Current next indicator	0 (not yet applicable) 1 (currently applicable)	Select through the list box or enter 0 or 1; the corresponding entry changes automatically.

You can define a BAT further by adding the following descriptors:

- Stuffing
- Bouquet_name
- Country_availability
- Linkage
- CA_identifier
- Private_data_specifier
- User defined

Refer to *SI Descriptors*, beginning on page 3-169, for more information. See the online help for a description of the syntax for this element.

CAT The Conditional Access Table provides the association between scrambled elementary streams and one or more conditional access systems. The association is specified in the conditional access descriptor loop; however, the table also tracks version number and current/next status.

Parameter	Possible Values	Notes
Version number	0 to 31	Incremented by 1 when the information contained in the table section changes.
Current next indicator	0 (not yet applicable) 1 (currently applicable)	Select through the list box or enter 0 or 1; the corresponding entry changes automatically.

You can further define a CAT by adding the Conditional_access descriptor

Refer to *PSI Descriptors*, beginning on page 3-163 for more information. See the online help for a description of the syntax for this element.

EIT (DVB)

The Event Information Table transmits information relating to all events that occur in the MPEG multiplex. The EIT contains information about the current transport stream and optionally covers other transport streams that the decoder can receive.

EIT parameter	Possible values	Notes
Table ID	78 (actual TS present/follow) 79 (other TS present/follow) 80 to 95 (actual TS, schedule) 96 to 111 (other TS, schedule)	Select through the list box or enter the appropriate number; the corresponding entry changes automatically.
Service ID	1 to 65535	Value is identical to the program defined in the corresponding PMT.
Current next indicator	0 (not yet applicable) 1 (currently applicable)	Select through the list box or enter 0 or 1; the corresponding entry changes automatically.
Section number	0 to 255	Is incremented by 1 for each additional section with the same table ID, service ID, TSID, and original network ID.
Last section number	0 to 255	The number of the last section with the same table ID, service ID, TSID, and original network ID.
Transport stream ID	0 to 65535	Identifies the transport stream that this EIT pertains to.
Original Network ID	0 to 65535	This is the network ID of the originating delivery system.
Segment last section number	0 to 255	The last section of this sub-table segment. If the sub-table is not segmented, it is the same as the last section number.
Last table ID	0 to 255	The last table ID used. Equal to the ID of this table, if there are no other tables.

EIT Events The EIT structure allows you to describe various aspects of events described elsewhere in the SI tables.

Parameter	Possible values	Notes
Event ID	0 to 65535	Identifies the event
Start time	Date Time (24 hour)	yyyy/mm/dd (today's date is suggested) hh/mm/ss
Duration	00:00:00 to 99:59:59	hh/mm/ss
Running status	0 (Undefined) 1 (Not running) 2 (Starts in a few seconds) 3 (Pausing) 4 (Running)	Select through the list box or enter the value and click the EIT icon; the table editor changes the corresponding entry.
Free CA mode	0 (Not scrambled) 1 (Scrambled)	Select through the list box; the table editor changes the numeric value.

You can further define EIT events by adding the following SI descriptors:

- Stuffing
- Linkage
- Short_event
- Extended_event
- Time_shifted_event
- Component
- CA_identifier
- Content
- Parental_rating
- Telephone
- Private_data_specifier
- Short_smoothing_buffer
- User defined

Refer to *SI Descriptors*, beginning on page 3-169, for more information. See the online help for a description of the syntax for this element.

PMT The Program Map Table identifies the streams that make up each service and the packets that contain the service streams and PCRs.

PMT parameter	Possible values	Notes
Program number	0 to 65535	Identifies the program.
Version number	0 to 31	Incremented by 1 when the information contained in the table section changes.
Current next indicator	0 (not yet applicable) 1 (currently applicable)	Select through the list box or enter 0 or 1; the corresponding entry changes automatically.
PCR PID	0 to 8191	The PID of the transport packets that contain the PCR fields for this program. By default, it is the PID of the first ES in the program. If you enter a PID other than those of the program streams, the PCRs reside in their own transport packets.

You can define a PMT further by adding the following descriptors:

- Registration
- Conditional_access
- ISO_639_language
- System_clock
- Multiplex_buffer_utilization
- Copyright
- Maximum_bitrate
- Private_data_indicator
- Smoothing_buffer
- Service_move
- User defined

Refer to *PSI Descriptors* (page 3-163) and *SI Descriptors* (page 3-169) for more information. See the online help for a description of the syntax for this element.

NIT The Network Information Table conveys information relating to the physical organization of the multiplexes (transport streams) carried on a given network and to the characteristics of the network itself.

NIT parameter	Possible values	Notes
Table ID	64 (actual network) 65 (other network)	Select through the list box or enter 64 or 65; the corresponding entry changes automatically.
Network ID	0 to 65535	ETSI publication ETR 162 lists valid IDs for various networks.
Version number	0 to 31	Incremented by 1 when the information contained in the table section changes.
Current next indicator	0 (not yet applicable) 1 (currently applicable)	Select through the list box or enter 0 or 1; the corresponding entry changes automatically.

You can define a NIT further by adding the following descriptors:

- Network_name
- Stuffing
- Linkage
- Private_data_specifier
- User defined

Refer to *SI Descriptors*, beginning on page 3-169, for more information. See the online help for a description of the syntax for this element.

RST The Running Status Table updates the timing status of one or more events, which may be necessary when a scheduling change causes an event to be early or late. The RST has no parameters or descriptors of its own; event parameters describe the event and indicate its running status.

Parameter	Possible values	Notes
Transport stream ID	0 to 65535	Identifies the transport stream to which the RST pertains; the TS can be in any multiplex within the delivery system.
Original Network ID	0 to 65535	This is the network ID of the originating delivery system.
Service ID	1 to 65535	Must be the same as the program number in the corresponding PMT.
Event ID	0 to 65535	Identifies the event.
Running status	0 (Undefined) 1 (Not running) 2 (Starts in a few seconds) 3 (Pausing) 4 (Running)	Select through the list box or enter the value and click the event icon; the table editor changes the corresponding entry.

Refer to *SI Descriptors*, beginning on page 3-169, for more information. See the online help for a description of the syntax for this element.

SDT The Service Description Table lists the names and other parameters associated with each service in a particular multiplex.

SDT parameter	Possible values	Notes
Table ID	66 (actual transport stream) 70 (other transport stream)	Select through the list box or enter 66 or 70; the corresponding entry changes automatically.
Transport stream ID	0 to 65535	Identifies the transport stream that this SDT pertains to.
Version number	0 to 31	Incremented by 1 when the information contained in the table section changes.
Current next indicator	0 (not yet applicable) 1 (currently applicable)	Select through the list box or enter 0 or 1; the corresponding entry changes automatically.
Original Network ID	0 to 65535	This is the network ID of the originating delivery system.

You can define a SDT further by adding the following descriptors:

- Stuffing
- Bouquet_name
- Service
- Country_availability
- Linkage
- NVOD_reference
- Time_shifted_service
- Mosaic
- CA_identifier
- Telephone
- Private_data_specifier
- Multilingual_service_name
- Data_broadcast
- User defined

Refer to *SI Descriptors*, beginning on page 3-169, for more information. See the online help for a description of the syntax for this element.

TOT The Time Offset Table carries the universal coordinated time, date, and local time offset for the current transport stream.

Parameter	Possible Values	Notes
UCT time:		
Date	YYYY/MM/DD (numeric)	Y = a digit for the year M = a digit for the month D = a digit for the day of the month
Time	XX:YY:ZZ	X = hours Y = minutes ZZ = seconds

You can also further define a TOT by adding the following descriptor:

- Local_time_offset

Refer to *SI Descriptors*, beginning on page 3-169, for more information. See the online help for a description of the syntax for this element.

TSDT The Transport Stream Description Table describes the transport stream primarily using the descriptor loop; however, the table also tracks version number and current/next status.

Parameter	Possible Values	Notes
Version number	0 to 31	Incremented by 1 when the information contained in the table section changes.
Current next indicator	0 (not yet applicable) 1 (currently applicable)	Select through the list box or enter 0 or 1; the corresponding entry changes automatically.

You can further define a TSDT by adding the following descriptors:

- Video_stream
- Audio_stream
- Hierarchy
- Registration
- Data_stream_alignment
- Target_background_grid
- Video_window
- Conditional_access
- ISO_639_language
- System_clock
- Multiplex_buffer_utilization
- Copyright
- Maximum_bitrate
- Private_data_indicator
- Smoothing_buffer
- STD
- IBP
- User defined

Refer to *SI Descriptors*, beginning on page 3-169, for more information. See the online help for a description of the syntax for this element.

**Elementary Streams
(in PMT)**

The PMT can have up to ten elementary streams. A transport stream (and therefore a single PMT) can have no more than five elementary streams of a given type.

ES PMT parameter	Possible values	Notes
Stream type	See Table 3-27	Select through the list box; the table editor changes the corresponding value.
Elementary PID	16 through 8190	Assigned automatically by the table editor; change to prevent conflicts with other elementary streams in other programs.

Table 3-27 on page 3-153 describes the options available in the stream type parameter selection box.

Table 3-27: Elementary stream types for MPEG-2 and DVB environments

Stream Type Description	Value
ITU-T ISO/IEC Reserved	0
ISO/IEC 11172 Video (MPEG1)	1
ITU-T Rec. H.262 ISO/IEC 13818-2 Video or ISO/IEC 11172-2 constrained parameter video stream	2
ISO/IEC 11172 Audio	3
ISO/IEC 13818-3 Audio	4
ITU-T Rec. H.222.0 ISO/IEC 13818-1 private_sections	5
ITU-T Rec. H.222.0 ISO/IEC 13818-1 PES packets containing private data	6
ISO/IEC 13522 MHEG	7
ITU-T Rec. H.222.0 ISO/IEC 13818-1 Annex A DSM CC	8
ITU-T Rec. H.222.1	9
ISO/IEC 13818-6 type A	10
ISO/IEC 13818-6 type B	11
ISO/IEC 13818-6 type C	12
ISO/IEC 13818-6 type D	13
ISO/IEC 13818-1 auxiliary	14
ITU-T Rec. H.222.0 ISO/IEC 13818-1 Reserved	15 – 127
User Private	128; 130 – 255
Audio Dolby AC-3 (user private)	129

You can further define an elementary stream by adding the following descriptors:

- Video_stream
- Audio_stream
- Hierarchy
- Registration
- Data_stream_alignment
- Target_background_grid
- Video_window
- Conditional_access
- ISO_639_language
- Multiplex_buffer_utilization
- Copyright
- Maximum_bitrate
- Private_data_indicator
- Smoothing_buffer
- STD
- IBP
- Mosaic
- Stream_identifier
- Teletext
- User defined

Refer to *PSI Descriptors* (page 3-163) and *SI Descriptors* (page 3-169) for more information.

**Transport Streams
(in NIT or BAT)**

The transport streams carried in a network or bouquet are uniquely identified by a combination of transport_stream_id and original_network_id.

Parameter	Possible values	Notes
Transport stream ID	0 to 65535	Identifies the transport stream; correlates to TSID parameters in the SDT and EIT following an analysis.
Original Network ID	0 to 65535	This is the network ID of the originating delivery system.

You can further define transport streams by adding the following SI descriptors:

- Service_list
- Stuffing
- Satellite_delivery_system
- Cable_delivery_system
- Terrestrial_delivery_system

- Private_data_specifier
- Frequency_list
- User defined

Refer to *SI Descriptors*, beginning on page 3-169, for more information.

PSIP Table Parameters

You can specify the parameters of the following ten PSI and PSIP tables using the MTS300 PSIP Table Editor:

- PAT
- PMT
- CAT
- EIT
- ETT
- MGT
- SST
- RRT
- TVCT and CVCT

This section describes the parameters for the PSIP tables listed above. See *PSI and SI Table Parameters*, on page 3-144 for similar information about PSI and SI table items, including the CAT. See pages 3-163, 3-169, and 3-185 for similar information about PSI, SI, and PSIP descriptor parameters respectively.

NOTE. *Although you can view and edit the contents of the PAT and CAT, you cannot export changes made to these files to the multiplexer. The PAT and CAT are created and updated dynamically by the multiplexer; PAT and CAT parameters can be edited for configuration files only from within the multiplexer.*

EIT (PSIP) The EIT contains information (title, start times, etc.) for events on defined virtual channels. An event is in most case, a typical TV program, however its definition may be extended to include particular data broadcasting session and other information segments.

Parameter	Possible Values	Notes
Source Id	0 to 65535	Specifies the source id of the virtual channel carrying the events described in this section. Located in the top level of EIT section.
Event Id	0 to 16383	Identification number of the event described. Located in the Event EIT element.
Start time	0 to 4 294 967 295	Input the start time as indicated: <i>XX/YY/ZZZZ AA:BB:CC</i> where: <i>XX</i> indicates the month (01 – 12) <i>YY</i> indicates day of the month (01 –31) <i>ZZZZ</i> indicates the year <i>AA</i> indicates the hour (00 – 23) <i>BB</i> indicates the minutes (00 – 59) <i>CC</i> indicates the seconds (00 – 59) Located in the Event EIT element.
ETM location	0 : No ETM 1 : ETM located in the PTC carrying this PSIP 2 : ETM located in the PTC specified by the channel_TSID 3 : [Reserved for future ATSC use]	
Length in second	0 to 1048576 (12 d, 3 h 16 m 15s)	Input the length of the event in hours, minutes, and seconds as described above for the Start time. Located in the Event EIT element.
Title text	Event title	Located in the Title multiple string structure.

An EIT can be further defined with the addition of the following descriptors:

- Stuffing
- User
- AC-3 audio
- Caption Service
- Content Advisory

See page 3–185 for descriptions of PSIP descriptors. See the online help for a description of the syntax for this element.

ETT The Extended Text Table contains one or more Extended Text Message (ETM) stream. ETTs are optional and are used to provide detailed description of virtual channels and events. An ETM is a multiple string data structure (see *Multiple String Structure* on page 3-162). An ETT can be a message that applies to a channel specified by the VCT, or an event specified by the EIT; the method of specifying the ETM_id is different depending on whether the ETT is an event or channel message.

Parameter	Possible values	Notes
ETM id		Unique 32 bit identifier of an extended text message.

An ETM_id is specified using the method describe in Table 3-28.

Table 3-28: Channel and Event ETM id

ETM_id type	First 5 digits (MSB 32....16)	Middle 5 digits (bits 15....2)	Last digit (LSB)
Channel ETM_id	source_id	0s	0 – 0
Event ETM_id	source_id	event_id	1 – 0

See the online help for a description of the syntax for this element.

MGT The Master Guide Table lists version numbers, length in bytes, and PIDs for all the PSIP tables with the exception of the STT, which is independent of the other PSIP tables.

This table is normally transmitted in only one section; however, several sections can be edited

Parameter	Possible values	Notes
Table type	See Table 3-29.	Identifies the type of the table which is described.
Table type PID	0 to 8191	Identifies the PID of the described table.
Table type version number	0 to 31	Identifies the version number of the described table.
Number bytes	0 to 4 294 967 295	Identifies the size in bytes of the the described table.

Table 3-29 describes the options available in the table type parameter drop-down box.

Table 3-29: Table type values for the MGT

Table type value	Meaning
0	Terrestrial VCT with current_next_indicator=1
1	Terrestrial VCT with current_next_indicator=0
2	Cable VCT with current_next_indicator=1
3	Cable VCT with current_next_indicator=0
4	Channel ETT
5-255-0x00FF	Reserved
256 to 383	EIT-0 to EIT-127
384 to 511	Reserved
512 to 639	Event ETT-0 to event ETT-127
640 to 768	Reserved
769 to 1023	RRT with rating_region 1 to255
1024 to 4095	User private
4096 to 65535	Reserved

A MGT can be further defined with the addition of the following descriptors:

- Stuffing
- User

See page 3-185 for descriptions of PSIP descriptors. See the online help for a description of the syntax for this element.

RRT The Rating Region Table (RRT) carries rating information for multiple geographical regions. Each RRT sub-table identifies a rating_region. This table is normally transmitted in only one section; however, several sections can be edited.

Parameter	Possible values	Notes
Rating Region	0 : Forbidden 1: US (50 states + possessions) 2 to 255 : Reserved	
Rating region name	Limited to 32 characters	Located in multiple string structure.
Dimension name	Limited to 20 characters	Located in Table Dimension multiple string structure.
Graduated scale	1 : graduated scale 2 : not graduated	Located in Table Dimension.
Abbrev rating value	Limited to 8 characters	Located in Dimension Value multiple string structure.
Rating value	Limited to 150 characters	Located in Dimension Value multiple string structure.

A RRT can be further defined with the addition of the following descriptors:

- Stuffing
- User

See page 3-185 for descriptions of PSIP descriptors. See the online help for a description of the syntax for this element.

STT The System Time Table provides the current date and time of day information. This table is normally transmitted in only one section; however, several sections can be edited.

Parameter	Possible values	Notes
GPS UTC offset	0 to 255	Current offset in whole second between GPS and UTC time standards.

A STT can be further defined with the addition of the following descriptors:

- Stuffing
- User

See page 3-185 for descriptions of PSIP descriptors. See the online help for a description of the syntax for this element.

VCT The Virtual Channel Table contains a list of attributes for virtual channel carried in the Transport Stream. A VCT can be specified for either Terrestrial broadcast (TVCT), or Cable broadcast (CVCT).

Parameter	Values	Notes
Transport stream id	0 to 65535	Identifies the transport stream Id.
Short name	7 UNICODE characters	
Major channel number	1 to 999	
Minor channel number	0 to 999	
Modulation mode	See the table below	Defines the used modulation.
Carrier frequency	0 to 4 294 967 295	
Channel TSID	0 to 65535	Identifies the Transport stream of the currently defined program.
Program number	0 to 65535	Identifies the program, which must match a program number in a PMT.
ETM location	0 : No ETM 1 : ETM located in the PTC carrying this PSIP 2 : ETM located in the PTC specified by the channel_TSID 3 : [Reserved for future ATSC use]	
Access controlled	1 : Events are access controlled 0 : Events are not restricted	
Hidden	1 : Not accessible by a direct entry in the VCT 0 : Accessible	
Path select ¹	0 : Path 1 1 : Path 2	
Out of band ¹	1 : Carried in an out of band physical transmission channel 0 : Carried within a standard tuned multiplex at that frequency	
Service type	See the table below	
Source id	0 to 65535	Identifies the programming sources associated with the virtual channel.

¹ Only used in the CVCT

Table 3-30 describes the options available in the drop-down selection box for the modulation mode parameter.

Table 3-30: Modulation mode values for the VCT

Modulation value	Associated modulation type
0	[Reserved]
1	Analog — The virtual channel is modulated using standard analog methods for analog television.
2	SCTE_mode_1 — The virtual channel has a symbol rate of 5.057 Msps, transmitted in accordance with <i>Digital Transmission Standard for Cable Television</i> , Ref. [12] (Mode 1). Typically, mode 1 will be used for 64 QAM.
3	SCTE_mode_2 — The virtual channel has a symbol rate of 5.361 Msps, transmitted in accordance with <i>Digital Transmission Standard for Cable Television</i> , Ref. [12] (Mode 2). Typically, mode 2 will be used for 256 QAM.
4	ATSC (8 VSB) — The virtual channel uses the 8-VSB modulation method conforming to the ATSC Digital Television Standard.
5	ATSC (16 VSB) — The virtual channel uses the 16-VSB modulation method conforming to the ATSC Digital Television Standard
6 to 127	[Reserved for future use by ATSC]
128	Modulation parameters are defined by a private descriptor
129 to 255	[User Private]

Table 3-31 describes the options available in the drop-down selection box for the service type parameter.

Table 3-31: Service type values for the VCT

Service type value	Associated service type
0	[Reserved]
1	Analog_television — The virtual channel carries analog television programming
2	ATSC_digital_television — The virtual channel carries television programming (audio, video and data) conforming to the ATSC Digital Television Standard
3	ATSC_audio_only — The virtual channel conforms to the ATSC Digital Television Standard, and has one or more standard audio and data components but no video.
4	ATSC_data_broadcast_service — Conforming to the ATSC data broadcast standard under development by T3/S13.
5 to 63	[Reserved for future ATSC use]

A TVCT and CVCT can be further defined with the addition of the following descriptors:

- Stuffing
- User
- Extended Channel Name
- Service Location
- Time-Shifted Service

See page 3-185 for descriptions of PSIP descriptors.

Multiple String Structure

This is a general data structure used specifically for text strings. Text strings appear as event titles, long channel names, the ETT messages, and RRT text items. The text in Multiple string structures is not compressed or uncompressed. If a table is opened with a compression mode the data can be displayed in hexadecimal mode.

Parameter	Possible values	Notes
ISO_639_language_code		3 bytes for the language code
Compression type	0 : No compression 1 : Huffman coding using standard encode/decode tables defined in Table C.4 and C.5 in Annex C. 2 : Huffman coding using standard encode/decode tables defined in Table C.6 and C.7 in Annex C. 3 to 175 : Reserved 176 to 255 : User private	
Mode		Text mode to be used to interpret characters.

PSI Descriptors

Descriptors are structures which may be used to extend the definitions of the elements to which they refer. This section describes the descriptor parameters for PSI structures. In most cases, a range of possible values is given for each descriptor.

See the online help for syntax descriptions of PSI descriptors.

Audio Stream Descriptor

The `audio_stream_descriptor` identifies the coding version of an audio elementary stream.

Parameter	Possible values	Notes
Free format flag	Bitrate index \neq 0000 (0) Bitrate index = 0000 (1)	Select through the list box; the table editor changes the numeric value.
ID	0 or 1	Set this to the same value as the ID fields in the audio stream.
Layer	0 to 3	Set this to the same value as the layer fields in the audio stream.
Variable rate audio indicator	No decoding discontinuity (0) Decoding discontinuity (1)	Select through the list box; the table editor changes the numeric value.

Conditional Access Descriptor

The `conditional_access_descriptor` is used, where required, to enable scrambling, either system-wide or of a service, program, elementary stream, or event.

Parameter	Possible values	Notes
CA system ID	0 to 65535	Indicates the applicable type of CA (scrambling) system; private and not defined in international standards.
CA PID	0 to 8191	The PID of the transport stream packets that contain conditional access (ECM or EMM) information.
Private data bytes	An even number of hexadecimal characters	May be specified by the CA system provider.

Copyright Descriptor

The `copyright_descriptor` can identify copyrighted work. The descriptor applies to the entire program when added to a PMT and to a single elementary stream when added to an ES.

Parameter	Possible values	Notes
Copyright identifier	0 through 2^{32}	Identifies the copyright registration authority; number is provided by ISO/IEC JTC1/SC29.
Additional copyright information	An even number of hexadecimal characters	May be specified by the copyright registration authority.

Data Stream Alignment Descriptor

The `data_stream_alignment_descriptor` indicates the type of alignment used in the elementary stream.

Parameter	Possible values	Notes
Alignment type	1 (Slice, video access unit, or audio syncword) 2 (Video access unit) 3 (GOP or SEQ) 4 (SEQ)	Select through the list box; the table editor changes the numeric value. (GOP = group of pictures)

Hierarchy Descriptor

The `hierarchy_descriptor` identifies program elements that contain parts of elementary streams that are multiplexed in multiple transport streams.

Parameter	Possible values	Notes
Hierarchy type	1 (Spatial scalability) 2 (SNR scalability) 3 (Temporal scalability) 4 (Data partitioning) 5 (Extension bitstream) 6 (Private stream) 15 (Base layer)	Select through the list box or enter the number and click the descriptor icon; the table editor changes the corresponding entry.
Hierarchy layer index	0 to 63	The hierarchy index of the elementary stream; no two streams in a program can have the same index.
Hierarchy embedded layer index	0 to 63	Defines the hierarchy table index of the program element that must be accessed before the elementary stream can be decoded.
Hierarchy channel	0 to 63	Indicates the intended transmission channel of the elementary stream.

IBP Descriptor The IBP_descriptor indicates how groups of (I, P, and B) pictures are encoded in the video elementary stream.

Parameter	Possible values	Notes
Closed GOP flag	0 or 1	Set to 1 when a group of pictures header is encoded before every I-frame.
Identical GOP flag	0 or 1	Set to 1 when the sequence of picture types between I-frames is the same throughout the sequence.
Max GOP length	1 to 16383	The maximum number of coded pictures between any two I-pictures in the sequence.

ISO 639 Language Descriptor The ISO_639_language_descriptor, through sub-descriptors, identifies the language or languages used in associated program elements. You can set two sub-descriptor parameters through the table editor.

Parameter	Possible values	Notes
ISO 639 language code	Three alpha characters	See ISO 639
Audio type	1 (clean effects) 2 (hearing impaired) 3 (visual impaired commentary)	Select through the list box; the table editor changes the numeric value.

Maximum Bitrate Descriptor The maximum_bitrate_descriptor indicates the highest bitrate, including transport overhead, to be encountered in the program or program element. If you add the descriptor to the PMT, the indicated bitrate applies to the entire program. If you add the descriptor to the ES icon, it applies to a single elementary stream.

Parameter	Possible values	Notes
Maximum bitrate	0 to 4194303 (2^{22})	Units are 50 bytes/second

Multiplex Buffer Utilization Descriptor

The `multiplex_buffer_utilization_descriptor` provides upper and lower time limits for occupancy of the T-STD multiplex decoder. This information may be used by some remultiplexing devices.

Parameter	Possible values	Notes
Bound valid flag	Not valid (0) Valid (1)	Applies to the LTW offset bounds of this descriptor; select through the list box; the table editor changes the numeric value.
LTW offset lower bound	0 to 32767	The lower limit, in (27 MHz/300) clock periods, of LTW offset values in the stream(s) referenced by this descriptor.
LTW offset Upper bound	0 to 32767	The upper limit, in (27 MHz/300) clock periods, of LTW offset values in the stream(s) referenced by this descriptor.

Private Data Descriptor

The `private_data_descriptor` can facilitate compatible private extensions to the PSI data stream.

Parameter	Possible values	Notes
Private data indicator	0 to 2^{32}	The value of this parameter has no universal meaning; the target decoder must be able to interpret the value.

Registration Descriptor

The `registration_descriptor` identifies private data formats.

Parameter	Possible values	Notes
Format identifier	0 to 2^{32}	Assigned by a registration authority.
Additional identification information.	An even number of hexadecimal characters	Defined by the assignee of the <code>format_identifier</code> .

Smoothing Buffer Descriptor

The `smoothing_buffer_descriptor` describes the smoothing buffer for the program or elementary stream.

Parameter	Possible values	Notes
SB leak rate	0 to 4194303 (2^{22})	The rate at which data is removed from the buffer, in units of 400 bits/second.
SB size	0 to 4194303 (2^{22})	Size of the smoothing buffer, in bytes.

STD Descriptor

The STD_descriptor determines how the T-STD transfers elementary stream data from the multiplex buffer to the elementary stream buffer. The leak method is the default, used if this descriptor is not present.

Parameter	Possible values	Notes
Leak valid flag	0 (VBV_delay method) 1 (Leak method)	Select through the list box; the table editor changes the numeric value.

System Clock Descriptor

The system_clock_descriptor conveys information about the system clock used to generate program time stamps.

Parameter	Possible values	Notes
External clock reference indicator	0 (Internal reference) 1 (External reference)	Select through the list box; the table editor changes the numeric value
Clock accuracy integer	0 to 63	These parameters together indicate system clock accuracy in ppm; if clock_accuracy_integer = 0, system clock accuracy is, by default, 30 ppm.
Clock accuracy exponent	0 to 7	

Target Background Grid Descriptor

The target_background_grid_descriptor, combined with the video_window_descriptor, determines the placement of an undersized picture on the display area. The target_background_grid_descriptor describes the display area.

Parameter	Possible values	Notes
Horizontal size	0 to 16383	Horizontal size, in pixels, of the target background grid (display area).
Vertical size	0 to 16383	Vertical size, in pixels, of the target background grid (display area).
Aspect ratio information	1 (1.0000) 2 (0.6735) 3 (0.7031) 4 (0.7615) 5 (0.8055) 6 (0.8437) 7 (0.8925) 8 (0.9157) 9 (0.9815) 10 (1.0255) 11 (1.0695) 12 (1.0950) 13 (1.1575) 14 (1.2015)	Select the correct ratio through the list box; the table editor automatically changes the parameter value. See ISO/IEC13818-2 for a definition of aspect_ratio_information.

Video Stream Descriptor

The video_stream_descriptor identifies the coding parameters of a video elementary stream.

Parameter	Possible values	Notes
Multiple frame rate flag	0 (Single frame rate) 1 (Multiple frame rates)	Select through the list box; the table editor changes the numeric value
Frame rate code	1 (23.976) 2 (24.0, 23.976*) 3 (25.0) 4 (29.97, 23.976*) 5 (30.0, 23.976*, 24*, 29.97*) 6 (50.0, 25.0*) 7 (59.94, 23.976*, 29.97*) 8 (60.0, 23.976*, 24.0*, 29.97*, 30.0*, 59.94*)	Frames per second Starred (*) rates are permitted when the multiple frame rate flag = 1
MPEG-1 only flag	0 (MPEG-1 or -2 video data) 1 (MPEG-1 video data)	Select through the list box; the table editor changes the numeric value.
Constrained parameter flag	0 or 1	Set to 0 when the video stream may contain both constrained and unconstrained video data; always set to 1 when the MPEG-1_only_flag is set to 0.
Still picture flag	0 (Moving and still pictures) 1 (Still pictures)	Available when the MPEG1_only_flag is 0; Select through the list box; the table editor automatically changes the numeric value.
Profile and level indicator	0 to 255	Available when the MPEG1_only_flag is 0; set this to the same value as the profile_and_level_indication fields in the video stream.
Chroma format	1 (4:2:0) 2 (4:2:2) 3 (4:4:4)	Available when the MPEG1_only_flag is 0; set this to the same value as the chroma_format fields in the video stream.
frame rate extension flag	0 or 1	Available when the MPEG1_only_flag is 0; set this flag to 1 when either the frame_rate_extension_n or the frame_rate_extension_d field in the video stream is non-zero.

Video Window Descriptor

The video_window_descriptor, combined with the target_background_grid_descriptor, determines the placement of an undersized picture (or window) on the display area. The video_window_descriptor determines the location of the smaller picture on the display area and the priority of the picture when it overlaps with other pictures on the same display.

Parameter	Possible values	Notes
Horizontal offset	0 to 16383	Horizontal position of the video window, in pixels, from the left edge of the background grid (display area).
Vertical offset	0 to 16383	Vertical position of the video window, in pixels, from the top edge of the background grid (display area).
Window priority	0 to 15	Zero is the lowest priority, 15 is the highest; windows with priority 15 are always visible.

SI Descriptors

Descriptors are structures which may be used to extend the definitions of the elements to which they refer. This section describes the descriptor parameters for SI structures. In most cases, a range of possible values is given for each descriptor. Descriptors are listed alphabetically.

See the online help for syntax descriptions of SI descriptors.

Bouquet Name Descriptor

The bouquet_name_descriptor carries the bouquet name in text form.

Parameter	Possible values	Notes
Name	Alphanumeric characters	—

CA Identifier Descriptor

The CA_identifier descriptor indicates that the bouquet, service, event, or component is associated with a conditional access system and identifies the type of CA system. You must add a sub-descriptor in order to specify the CA system; the table lists values for the CA system sub-descriptor parameter.

Parameter	Possible values	Notes
CA system ID	Reserved (0) Standardized Systems (1) Canal Plus (256) CCETT (512) Deutch Telecom (768) Eurodec (1024) France Telecom (1280) Irdeto (1536) Jerrold/GI (1792) Matra Communication (2048) News Datacom (2304) Nokia (2560) Norwegian Telecom (2816) NTL (3072) Philips (3328) Scientific Atlanta (3584) Sony (3840) Tandberg Television (4096) Thomson (4352) TV/Com (4608) HPT—Croatian P&T (4864) HRT—Croatian R&TV (5120) IBM (5376) Nera (5632) BetaTechnik (5888)	When you select the system ID through the list box, the table editor automatically changes the numeric value. Each CA system specifier has been assigned a range of numeric values; see ETR 162 for more information. Enter an appropriate number in the value box and click the sub-descriptor icon; the table editor automatically changes the CA system specifier name to match.

Cable Delivery System Descriptor

The cable_delivery_system descriptor identifies the characteristics of the cable delivery system.

Parameter	Possible values	Notes
Frequency	0000.0000 to 9999.9999	MHz
FEC outer	1 (No outer FEC coding) 2 (RS 204/188)	Select through the list box or enter the appropriate value and click the descriptor icon.
Modulation	1 (16 QAM) 2 (32 QAM) 3 (64 QAM) 4 (128 QAM) 5 (256 QAM)	Select through the list box or enter the appropriate value and click the descriptor icon; the application makes the appropriate entry in the corresponding field.
Symbol rate	000.0000 to 999.9999	Msymbols/second.
FEC inner	1 (1/2 conv. code rate) 2 (2/3 conv. code rate) 3 (3/4 conv. code rate) 4 (5/6 conv. code rate) 5 (7/8 conv. code rate) 15 (No conv. coding)	Select through the list box or enter the appropriate value and click the descriptor icon; the application makes the appropriate entry in the corresponding field.

Component Descriptor

The component_descriptor identifies the type of component stream and may be used to provide a text description of the elementary stream.

Parameter	Possible values	Notes
Stream content	1 (Video) 2 (Audio) 3 (Teletext)	Select through the list box or enter the appropriate value and click the descriptor icon; the application makes the appropriate entry in the corresponding field.
Component type	Value depends on stream content; see Table 3-32	
Component tag	0 to 255	Enter the same value as in the PMT stream_identifier descriptor (if present).
ISO 639 language code	A 3-character language code as defined in ISO 639	Use when the stream content is audio or teletext.
Description	Alphanumeric characters	A text description of the elementary stream.

The possible component types depend on the value of the stream content parameter.

Table 3-32: Component type values

Stream Content	Possible component type values
Video (1)	1 (4:3 aspect ratio) 2 (16:9 aspect ratio with pan vectors) 3 (16:9 aspect ratio without pan vectors) 4 (Greater than 16:9 aspect ratio)
Audio (2)	1 (Single mono channel) 2 (Dual mono channel) 3 (Stereo (2 channel)) 4 (Multi-lingual, multi-channel) 5 (Surround sound) 64 (For visually impaired) 65 (For the hard of hearing)
Teletext (3)	1 (EBU teletext subtitles) 2 (Associated EBU teletext) 10 through 13, 32 through 35 (Various DVB subtitle types; refer to ETS 300 468)

Content Descriptor

The content_descriptor classifies event content. ETS 300 468 lists more than 75 content classifications such as “motor sport” or “musical/opera.” The content descriptor must have a content nibble sub-descriptor. The following table describes the sub-descriptor parameters.

Parameter	Possible values	Notes
Content nibble level 1	1 (Movie) 2 (News/current affairs) 3 (Show/game show) 4 (Sports) 5 (Children/youth programs) 6 (Music/ballet/dance) 7 (Arts/culture) 8 (Social/political/economics) 9 (Education/science/factual) 10 (Leisure hobbies)	The content class. Select through the list box; the table editor automatically changes the numeric value. You may also enter an appropriate number in the value box and click the sub-descriptor icon; the table editor automatically changes the CA system specifier name to match.
Content nibble level 2	Choices depend on and correspond to the level 1 selection. See ETS 300 468 for a complete list.	The content sub-class. Select through the list box, the table editor automatically changes the numeric value.
User nibble (2 fields)	0 to 15	Defined by the broadcaster

Country Availability Descriptor

The `country_availability_descriptor` can list either the countries for which the bouquet or service is intended or countries for which it is not intended. You can add both an intended and a not intended descriptor; if the lists conflict, the not intended descriptor takes precedence.

Parameter	Possible values	Notes
Country availability flag	0 (Not intended) 1 (Intended)	Enter the flag value or select from the list box.
Country code	One or more 3-character country codes as specified in ISO 3166 [2] or ETR 162	Do not insert spaces between the codes. For example, to specify both the UK and Scandinavia, enter GBR900.

Extended Event Descriptor

The `extended_event_descriptor` can provide a detailed description of an event. You may use a set of up to 16 extended event descriptors in addition to the short event descriptor.

Parameter	Possible values	Notes
Descriptor number	0 to 15	Determines the order of this descriptor in the set of associated descriptors.
Last descriptor number	0 to 15	The number of the last descriptor in this set of extended event descriptors.
ISO 639 language code	A 3-character language code as defined in ISO 639	The language of the descriptor text.
Text char	Up to 256 alphanumeric characters	The descriptor text.

You can use extended event sub-descriptors to arrange text into two columns. Each sub-descriptor Edit window has an “item description char” field and an “item char” field. In a typical application, the information in the extended event sub-descriptors is arranged as follows:

```

item_description_chars_1    item_chars_1
item_description_chars_2    item_chars_2
item_description_chars_3    item_chars_3

```

Actual content could resemble the following:

```

Title:      MTS300 Series, The Movie
Director:   John D. Rector
Producer:   Jack Producer

```

The number of sub-descriptors appears as “Nb item:” (in gray characters) on the extended event descriptor Edit window.

Frequency List Descriptor

If a transport stream is to be transmitted over multiple frequencies, the `frequency_list_descriptor` provides a complete list of frequencies. The `frequency_list_descriptor` itself describes the deliver system for the frequency specified in the `center_frequency` sub-descriptor

Parameters	Possible values	Notes
Coding type	0 : Not defined 1 : Satellite 2 : Cable 3 : Terrestrial	Select through the list boxes or enter the appropriate value and click the descriptor icon; the application makes the appropriate entry in the corresponding field.
Center frequency		Sub-descriptor. Enter the values in 10 Hz increments.

Linkage Descriptor

The `linkage_descriptor` identifies a service that can be presented when the consumer requests additional information.

Parameter	Possible values	Notes
Transport stream ID	0 to 65535	Identifies the TS that contains the indicated information service
Original network ID	0 to 65535	The network ID of the originating delivery system for the indicated information service.
Service ID	0 to 65535	Uniquely identifies an information service within a transport stream; must be the same as the program number in the corresponding PMT.
Linkage type	1 (Information) 2 (Electronic program guide) 3 (CA replacement)	Enter the value or select from the list box.
Private data bytes	An even number of hexadecimal characters	

Local Time Offset Descriptor

The local_time_offset descriptor allows you to add a local time offset to the TOT.

Parameter	Possible values	Notes
Country code	A (a) through Z (z)	Three letter country identifier
Country region ID	0 to 63	Zone in the country indicated by the country_code parameter (if the country includes more than one zone).
Local time offset polarity	0: Positive polarity 1: Negative polarity	Direction to apply the offset from UTC. Positive polarity indicates that the local time is ahead of UTC; negative polarity indicates that the local time is behind UTC.
Local time offset	XX:YY X = hours (0 through 24) Y = minutes (0 through 60)	Current offset time relative to UTC
Time of change: Date	YYYY/MM/DD (numeric)	Y = year M = month 1 through 12 D = day of the month (1 through 31)
Time	XX:YY:ZZ	X = hours (0 through 24) Y = minutes (0 through 60) ZZ = seconds (0 through 60)
Next time offset	XX:YY X = hours (0 through 24) Y = minutes (0 through 60)	Next offset time when the time change occurs.
UCT time: Date	YYYY/MM/DD (numeric)	Y = year M = month)1 through 12) D = day of the month (1 through 31)
Time	XX:YY:ZZ	X = hours (0 through 24) Y = minutes (0 through 60) ZZ = seconds (0 through 60)

Multilingual Service, Component and Bouquet Name Descriptors

The `multilingual_service_name_descriptor` provides the service name in one or more languages. The descriptor itself indicates the number of sub-descriptors used (you can describe a service in any number of languages, however, you need to use a sub-descriptor for each language). The sub-descriptor parameters are described below.

Parameter	Possible values	Notes
ISO 639 language code	Three alpha characters	See ISO 639
Service provider name	Alpha-numeric characters	This field is not used for the component or bouquet name sub-descriptors.
Service name	Alpha-numeric characters	This field is analogous to the Bouquet name and the Text description parameters in the <code>multilingual_bouquet_name</code> and the <code>multilingual_component_name</code> sub-descriptors.

The definitions provided in the preceding table for the ISO 639 and the Service name sub-descriptor parameters are also used for the following descriptors:

- `multilingual_bouquet_name_descriptor`
- `multilingual_component_name_descriptor`

Mosaic Descriptor

The `mosaic_descriptor` and sub-descriptors can describe a mosaic component, which is a collection of different video images that form a coded video component. Each video image occupies a small region of the screen. The information in the descriptors and sub-descriptors determines the content and arrangement of the mosaic. Refer to ETS 300 468 for a full explanation of the mosaic descriptor and sub-descriptors.

Parameter	Possible values	Notes
Mosaic entry point	0 or 1	A value of 1 indicates that this mosaic is the highest in a hierarchy.
Nb of horizontal elementary cells	0 (one cell) 1 (two cells) ... 7 (eight cells)	Cells = value+1 Enter the value or select from the list box.
Nb of vertical elementary cells	0 (one cell) 1 (two cells) ... 7 (eight cells)	Cells = value+1 Enter the value or select from the list box.

The mosaic sub-descriptors have the following parameters:

Parameter	Possible values	Notes
Logical cell ID	0 to 63	
Cell presentation info	0 (undefined) 1 (video) 2 (still picture) 3 (graphics/text)	Enter the value or select from the list box.
Cell linkage info	0 (undefined) 1 (bouquet related) 2 (service related) 3 (other mosaic related) 4 (event related)	Enter the value or select from the list box.
Bouquet ID	0 through 65535	Present only if the cell linkage info value is 1.
Original network ID	0 through 65535	Present when cell linkage info value is 2, 3, or 4.
Transport stream ID	0 through 65535	
Service ID	0 through 65535	
Event ID	0 through 65535	Present only if the cell linkage info value is 4.

Each mosaic sub-descriptor may have several sub-sub-descriptors. The sub-sub-descriptors have only one parameter, the elementary cell ID, which can have a numeric value from 0 to 63.

Network Name Descriptor

The `network_name_descriptor` provides the network name.

Parameter	Possible values	Notes
Network name	Alphanumeric characters	The network name

NVOD Reference Descriptor

The `NVOD_reference_descriptor`, in conjunction with the time-shifted service and time-shifted event descriptors, provide a mechanism for describing a group of services that carry the same event sequence at start times that are offset from one another. Such a group of time-shifted services is known as near video on demand, or NVOD.

The NVOD reference descriptor uses sub-descriptors to list the services that together form an NVOD service. The following table lists the NVOD reference sub-descriptor parameters.

Parameter	Possible values	Notes
Transport stream ID	0 to 65535	Identifies the TS that contains the service.
Original network ID	0 to 65535	The network ID of the originating delivery system for the service.
Service ID	0 to 65535	Uniquely identifies the service within a transport stream; must be the same as the program number in the corresponding PMT.

Parental Rating Descriptor

The `parental_rating_descriptor`, through sub-descriptors, can contain a rating based on country and age of the potential viewers. The following table lists the parental rating sub-descriptor parameters.

Parameter	Possible values	Notes
Country code	A 3-character country code	Codes are specified in ISO 3166 [2]
Rating (+3 = minimum age)	1 to 15	The suggested minimum age of viewers is the rating plus three; thus a rating of 4 suggests that viewers should be at least 7 years old.

Private Data Specifier Descriptor

The `private_data_specifier_descriptor` identifies the source of private data used in the SI stream so the decoder can reliably interpret the private data. The location of this descriptor determines the entities (network, bouquet, events, or services) to which it applies; refer to ETS 300 468 for a complete explanation.

Parameter	Possible values	Notes
Private data specifier	0 to 2^{32}	Assigned in ETR 162 [6]

Satellite Delivery System Descriptor

The `satellite_delivery_system_descriptor` identifies the characteristics of the satellite delivery system.

Parameter	Possible values	Notes
Frequency (GHz)	000.00000 to 999.99999	—
Orbital position	000.0 to 999.9	Degrees; many possible entries are meaningless.
West east flag	0 (Western position) 1 (Eastern position)	Enter the value or select from the list box.
Polarization	0 (linear–horizontal) 1 (linear–vertical) 2 (circular–left) 3 (circular–right)	Enter the value or select from the list box.
Modulation	0 (undefined) 1 (QPSK)	Enter the value or select from the list box.
Symbol rate	000.0000 to 999.9999	Msymbols/second.
FEC inner	1 (1/2 conv. code rate) 2 (2/3 conv. code rate) 3 (3/4 conv. code rate) 4 (5/6 conv. code rate) 5 (7/8 conv. code rate) 15 (No conv. coding)	Select through the list box or enter the appropriate value and click the descriptor icon; the application makes the appropriate entry in the corresponding field.

Service Descriptor

The `service_descriptor` provides the service type, service name, and service provider.

Parameter	Possible values	Notes
Service type	0 (reserved) 1 (digital television) 2 (digital radio sound) 3 (teletext) 4 (NVOD reference) 5 (NVOD time-shifted service) 6 (mosaic) 7 (PAL coded signal) 8 (SECAM coded signal) 9 (D/D2–MAC) 10 (FM radio) 128 to 254 (user defined)	Select through the list box or enter the appropriate value and click the descriptor icon; the application makes the appropriate entry in the corresponding field.
Provider name	Alphanumeric text	
Service name	Alphanumeric text	

Service List Descriptor

The `service_list_descriptor` uses sub-descriptors to list the services in a transport stream by service ID and type. The table lists the service list sub-descriptor parameters.

Parameter	Possible values	Notes
Service ID	0 to 65535	Uniquely identifies the service within a transport stream; must be the same as the program number in the corresponding PMT except when the service type is NVOD reference.
Service type	0 (reserved) 1 (digital television) 2 (digital radio sound) 3 (teletext) 4 (NVOD reference) 5 (NVOD time-shifted service) 6 (mosaic) 7 (PAL coded signal) 8 (SECAM coded signal) 9 (D/D2-MAC) 10 (FM radio) 128 to 254 (user defined)	Select through the list box or enter the appropriate value and click the descriptor icon; the application makes the appropriate entry in the corresponding field.

Service Move Descriptor

The `service_move_descriptor` enables a decoder to track a service as it is moved from one transport stream to another.

Parameter	Possible values	Notes
New original network ID	0 to 65535	The ONID of the transport stream after the move.
New transport stream ID	0 to 65535	The TSID after the move.

Short Event Descriptor

The short_event descriptor provides the event name and a short text description of the event. If a longer description is required, use up to 15 extended event descriptors in addition to this descriptor.

Parameter	Possible values	Notes
ISO 639 language code	A 3-character language code as defined in ISO 639	The language of the text used in this descriptor.
Event name	Alphanumeric text	
Description	Alphanumeric text	

Short Smoothing Buffer Descriptor

The short_smoothing_buffer_descriptor can appear in EIT present/following and EIT schedule tables to indicate the bit rate of each event.

Parameter	Possible values	Notes
SB size	0 (DVB reserved) 1 (buffer = 1536 bytes)	Enter the value or select from the list box
SB leak rate	0 (DVB reserved) 1 (0.0009 Mbits/s) 2 (0.0018 Mbits/s) ... 60 (108.0 Mbits/s)	Refer to ETS 300 468 for a complete list of possible values. Select through the list box or enter the appropriate value and click the descriptor icon; the application makes the appropriate entry in the corresponding field.
DVB reserved bytes	An even number of hexadecimal characters	—

Stream Identifier Descriptor

The stream_identifier_descriptor can attach a component tag to PMT transport stream descriptions. This component tag allows the EIT, through the same tag in a component descriptor, to reference the stream.

Parameter	Possible values	Notes
Component tag	0 to 255	—

Stuffing Descriptor

The stuffing_descriptor provides a means of inserting dummy descriptors for table stuffing.

Parameter	Possible values	Notes
Descriptor length	0 to 255	Bytes

Telephone Descriptor

The telephone_descriptor provides a telephone number that can be used for modem dial-up; communication via modem may be used with narrow band interactive channels.

Parameter	Possible values	Notes
Foreign availability	0 (from inside the country) 1 (from outside the country)	Enter the value or select from the list box
Connection type	0 to 31	Type must be recognized by the decoder
Country prefix	Alphanumeric characters	Consistent with international and local telecommunications standards.
Int'l area code	Alphanumeric characters	
Operator code	Alphanumeric characters	
National area code	Alphanumeric characters	
Core number	Alphanumeric characters	

Teletext Descriptor

The teletext_descriptor, with sub-descriptors, can appear in an ES definition in the PMT to identify streams that contain EBU teletext data. The table lists the teletext sub-descriptor parameters.

Parameter	Possible values	Notes
ISO 639 language code	A 3-character language code as defined in ISO 639	The language of the teletext data.
Teletext type	1 (initial teletext page) 2 (teletext subtitle page) 3 (addit'l information page) 4 (program schedule page)	Select through the list box or enter the appropriate value and click the descriptor icon; the application makes the appropriate entry in the corresponding field.
Teletext magazine number	0 to 7	Identifies the magazine.
Teletext page number	0 to 255	Identifies the page.

Terrestrial Delivery System Descriptor

The `terrestrial_delivery_system` descriptor identifies the characteristics of the terrestrial delivery system.

Parameter	Possible values	Notes
Center frequency	10 to 42,949,672,950	Type value in 10 Hz increments
Bandwidth	0 : 8 MHz 1 : 7 MHz	Select through the list boxes or enter the appropriate value and click the descriptor icon.
Constellation	0 : QPSK 1 : 16 QAM 2 : 64 QAM	
Hierarchy information	0 : Non-hierarchical 1 : Alpha = 1 2 : Alpha = 2 3 : Alpha = 4	
Code rate HP stream	0 : 1/2 1 : 2/3 2 : 3/4 3 : 5/6 4 : 7/8	
Code rate LP stream	0 : 1/2 1 : 2/3 2 : 3/4 3 : 5/6 4 : 7/8	
Guard interval	0 : 1/32 1 : 1/16 2 : 1/8 3 : 1/4	
Transmission mode	0 : 2k 1 : 8k	
Other frequency flag	0 : No other frequency in use 1 : Other frequency in use	

Time Shifted Event Descriptor

The `time_shifted_event_descriptor` identifies an event that is a time-shifted copy of another event.

Parameter	Possible values	Notes
Reference service ID	0 to 65535	The ID of the NVOD reference service.
Reference event ID	0 to 65535	Identifies the reference event (of which this event is a copy).

Time Shifted Service Descriptor

The `time_shifted_service_descriptor` identifies a service that is a time-shifted copy of another service.

Parameter	Possible values	Notes
Reference service ID	0 to 65535	The ID of the NVOD reference service (of which this service is a copy); does not have a corresponding service in the PMT.

User Descriptor

You can define a descriptor and add it to almost any table, stream, service, or event definition.

Parameter	Possible values	Notes
Descriptor tag	128 to 254	Define your own.
Private bytes	An even number of hexadecimal characters	—

PSIP Descriptors

Descriptors are structures which may be used to extend the definitions of the elements to which they refer. This section describes the descriptor parameters for PSIP structures. In most cases, a range of possible values is given for each descriptor. Descriptors are listed alphabetically. Descriptors are listed alphabetically.

See the online help for syntax descriptions of PSIP descriptors.

AC-3 Audio Descriptor

The AC-3 Audio Descriptor provides information on the audio elementary stream.

Parameter	Possible values	Notes
Sample rate code	0 : 48 kHz 1 : 44.1 kHz 2 : 32 kHz 3 : Reserved 4 : 48 kHz or 44.1 kHz 5 : 48 kHz or 32 kHz 6 : 44.1 kHz or 32 kHz 7 : 48 kHz or 44.1 kHz or 32 kHz	Indicates the sample rate of the associated AC-3 audio stream.
Bsid		The same value as the bsid field in the associated AC-3 audio stream.
Bit rate code		Indicates the bit rate.
Surround mode	0 : Not indicated 1 : Not Dolby Surround encoded 2 : Dolby Surround encoded 3 : Reserved	Indicates whether Dolby Surround is used.
Bsmod		The same value as the bsmod field in the associated AC-3 audio stream.
Num channels		Indicates the number of channels for the associated AC-3 audio stream
Full svc	1 : Full service suitable for presentation 0 : Not sufficiently complete to be presented without being combined with another audio service	
Langcod	0 : Language is unknown	The same value as the Langcod field in the associated AC-3 audio stream.
Langcod2		The same value as the Langcod2 field in the associated AC-3 audio stream.

Parameter	Possible values	Notes
Mainid	0 to 7	Identifies a unique main audio service.
Asvcflags	0 to 7	Indicates the main audio service with which this partial audio service must be combined.
Text code	1 : Text is 1 byte characters encoded using the ISO Latin 1 alphabet 0 : UNICODE	

Caption Service Descriptor

The Caption Service Descriptor provides closed captioning information, such as closed captioning type and language code

Parameter	Possible values	Notes
Language		A 3 byte language code
CC_type	1 : Advance television close caption service is present 0 : Not present	
Line21 field	1 : Line 21 closed caption service is associated with field 1 of the NTSC waveform 0 : Not present	
Caption service number	0 to 63	
Easy reader	1 : Text tailored to the needs of beginning readers 0 : Not tailored	
Wide aspect ratio	1 : Formatted for displays with 16 :9 ratio 0 : Formatted for the 4 :3 ratio	

Component Name Descriptor

The Component Name Descriptor is a multiple string structure that defines an optional textual name tag for any component of the service. (See *Multiple String Structure* on page 3-162.)

Content Advisory Descriptor

The Content Advisory Descriptor indicates, for a given event, ratings for any or all the rating dimension defined in the RRT.

Parameter	Possible values	Notes
Rating region	0 to 255	Indicates the RRT with the matching information.
Rating dimension j	0 to 255	The dimension index in the RRT rating region.
Rating value	0 to 15	The rating value of the rating dimension j in the RRT rating region.
Rating description text		Field is limited to 16 characters.

Extended Channel Name Descriptor

The Extended Channel Name Descriptor is a multiple string structure that provides a long channel name for the VCT. (See *Multiple String Structure* on page 3-162.)

Program Identifier Descriptor

The Program Identifier Descriptor provides a means of identify programs in the PMT.

Parameter	Possible values	Notes
Provider index	0 to 65353	This 16 bit unsigned integer field identifies the provider that assigns the program_event_id
Program event id	0 to 16,777,215	This 24 bit unsigned integer field identifies the program or product.
Provider index	0 to 65353	This 16 bit unsigned integer field identifies the provider that assigns the program_event_id
Program event id	0 to 16,777,215	This 24 bit unsigned integer field identifies the program or product.
Episode number	This 12 bit unsigned integer number identifies the version of the production or episode (1 to 4095 inclusive). Different versions of the program/production may be assigned for different languages, program lengths, different titles for the same program/product, etc.	
Version number	For instance, a film product may be released as a 120 minute version in English for North American theatrical release, a 180 minute version in French for European theatrical release, and a 110 minute release in English and French for use on Canadian television.	

Parameter	Possible values	Notes
Original date year	This 8 bit unsigned integer number represents the offset from 1900 to the year of first presentation. Year minus 1900; that is. if first presentation was 1984, the original_date_year would have a value of 84 or 0x54).	
Original date month	1 = January - 12 = December	
Original date day	1to31	
Program id string	A sequence of zero to 40 characters which represent a human-readable version of the Program Identifier. The characters are coded according to ISO/IEC 8859-1 (Latin-1). The program_id_string is not intended for display or processing by consumer equipment; it may be provided by the creator of the program_id_string as a human-readable reference check on the Program Identifier.	
ISAN field	The 9 byte optional field may be used to cross-reference the ISAN number for the program when one exists. ISAN is an identification system used for certain audio/visual properties. It consists of a 16 digit integer number coded in bcd (binary-coded-decimal) notation in a 64 bit (8 byte) string. The most significant byte of the ISAN_field is used to carry the ISAN registration authority eight bit value	

Service Location Descriptor

The Service Location Descriptor provides the stream types, PID and language code for each elementary stream.

Parameter	Possible values	Notes
PCR_PID	0 to 8191	The PID of the transport packets carrying the PCR information for the Elementary stream.
Stream type	0 : Reserved 1 : ISO/IEC 11172-2 Video 2 : ISO/IEC 13818-2 Video 3 : ISO/IEC 11172-3 Video 4 : ISO/IEC 13818-3 Audio 5 : ISO/IEC 13818-1 private section 6 : ISO/IEC13818-1 PES 7 : ISO/IEC 13522 MHEG 8 : ISO/IEC 13818-1 Annex A DSM 9 : IUT-T Rec. H.222.1 10 : ISO/IEC 13818-6 type A 11 : ISO/IEC 13818-6 type B 12 : ISO/IEC 13818-6 type C 13 : ISO/IEC 13818-6 type D 14 : ISO/IEC 13818-6 auxiliary 15 : ISO/IEC 13818-7 Audio w/ADT 16 to 127 : Reserved 128 : User private 129 : Audio Dolby AC-3	Select the stream type from the selection box, and the table editor will change the appropriate value.
elementary PID	0 to 8191	PID of the transports packets carrying this Elementary stream
IOS 639 language code		3 bytes language code

Time-Shifted Service Location Descriptor

The Time-Shifted Service Location Descriptor links one virtual channel with one or more virtual channels that carry the same programming on a time-shifted basis.

Parameter	Possible values	Notes
Time shift	0 to 720	The number of minutes the services indicated by the major/minor channel number are time shifted.
Major channel number	1 to 999	The index on the major channel number.
Minor channel number	0 to 999	The index on the minor channel number.

Using the Jitter Adder

The Jitter Adder application allows you to create transport stream files with known multiplex errors. By introducing errors into the PCRs, transmission delay variations can be simulated. Use these transport streams to test the robustness of decoders under various conditions.

This application opens a transport stream file (*.trp), introduces clock jitter, and creates a new *.trp file.

This section explains the commands available from the Jitter Adder application.

Application

The main purpose of Jitter Adder files is to aid in the design of decoder PLLs. The errors produced by the Jitter Adder application introduce known amounts of jitter into the transport stream. The application modulates the data values of the PCRs away from their correct values.

Use the Jitter Adder transport stream files in real-time hardware experiments at the receiver. The receiving PLL will have to filter out the introduced modulations in order to produce a stable clock reference. You can use the MTS300 MPEG Test System test system Deferred-Time Analyzer application to view Jitter Adder errors introduced into the PCR data.

Terms

This application is similar to the Multiplexer application in that it outputs a transport stream file not a transport stream. Since there is an important difference between the two terms, the definitions are repeated here for emphasis.

A transport stream is the signal that comes out of (or into) one of the connectors on the rear panel of the Tektronix MTS300 MPEG Test System.

A transport stream file is a file on a disk. When the test system sends this file out one of the rear panel connectors (properly timed), it becomes a transport stream.

Starting the Application

Double-click the **Jitter Adder** icon in the **Tektronix MPEG Test System** program group window to start the application.

Menu Commands

The Jitter Adder menu commands are shown in the following table.

Menu	Command	Function
File	Open	Opens a transport stream file for addition of jitter
	Quit	Exits the Jitter Adder application
Jitter	Definition	Allows you to define the PCRs and type of jitter added
	Calculate	Calculates a new transport stream file with jitter added (*.jit)
Help	Contents	Provides help for the Jitter Adder application
	Using Help	Obtain information on the Help system
	About Jitter Adder	Displays application version and copyright information.

File Menu The File Menu commands select transport streams and close the application.



Open. Opens the **Multiplex Transport File** dialog box.

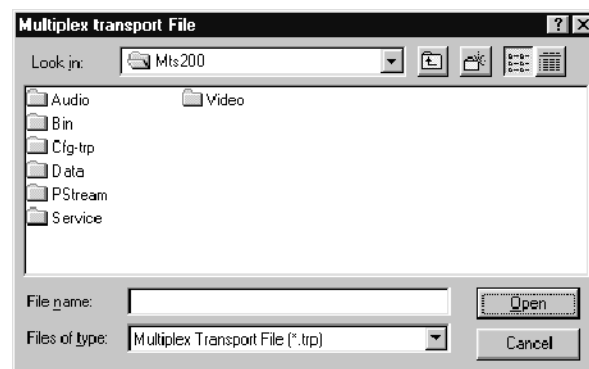

Select a file from the **File Name** list and click **OK**. This returns the **List of Programs** window in the application window. Use this as a quick reference for PID numbers when defining jitter.

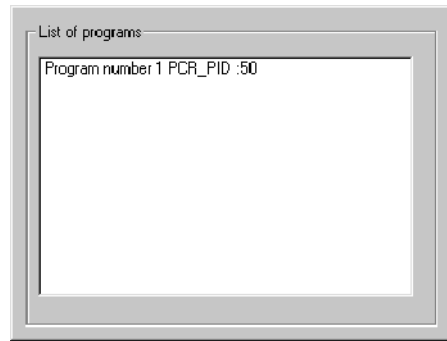

Quit. Closes the Jitter Adder application. No verification of the Quit command is given before exiting the application.

Jitter Menu The Jitter Menu commands set parameters and initiate calculations.

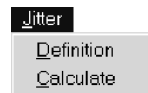

Definition. Opens the **PCR Clock Selection** dialog box.

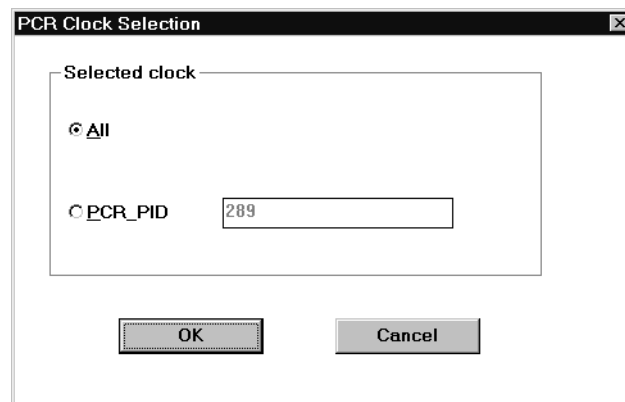

Use this dialog box to choose if the jitter calculation is done to all PCR clocks or to only the PCR for one PID (program). You can have a set of reference PCRs in the same transport stream file.

Once the option is selected, click **OK**. This opens the **Jitter Type** dialog box.

Use this dialog box to set the jitter parameters inserted into the PCR. Select from: Offset, Square, Sine, or Random. Only one option is allowed.

- **Offset**. Adds the time (in seconds) entered in the **Value text** box to the PCR:

$$PCR = PCR + offset$$

- **Square**. Adds the time (in seconds) defined by the following equation to the PCR:

$$PCR(n) = PCR(n) + square(t)$$

Square(t) is the value of the square wave defined by the **Amplitude** and **Period text** boxes at the time defined by PCR(n). See Figure 3-1.

Using PCR2 from Figure 3-1 as an example, the value of the square wave at PCR2 is A. After jitter is applied, PCR2 = PCR2 + A.

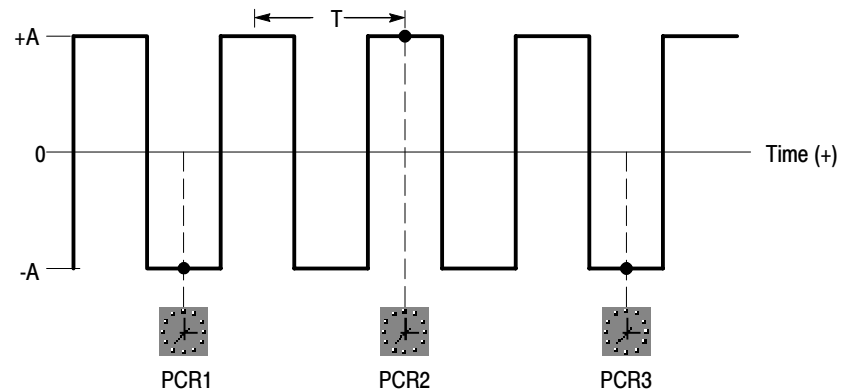

Figure 3-1: Illustration of the square jitter function

- Sine. Adds the time (in seconds) defined by the following equation to the PCR:

$$PCR(n) = PCR(n) + A\sin(t)$$

$A\sin(t)$ is the value of the sine function defined by the **Amplitude** and **Period** entered in the text box boxes at the time defined by $PCR(n)$. See Figure 3-2.

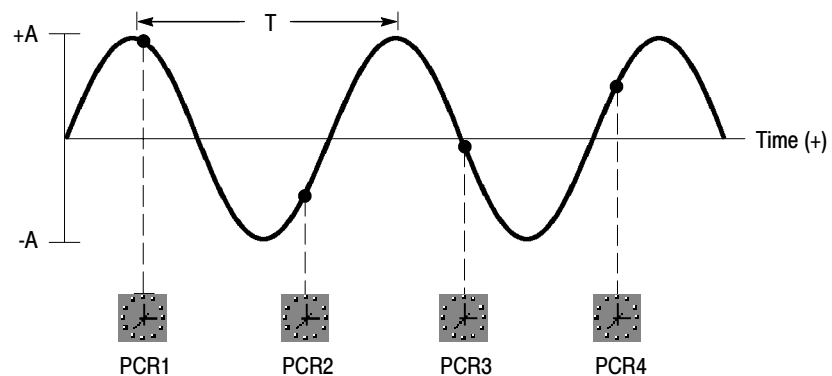

Figure 3-2: Illustration of the sine jitter function

Using PCR2 from Figure 3-2 as an example, the sine wave value at PCR2 is $-0.55A$. After jitter is applied, PCR2 will equal the correct value of PCR2 less $0.55A$.

- **Random.** Adds a uniformly distributed random value to the PCR. The range of values is between 0 and the value (plus or minus) defined in the **Value** box in seconds:

$$PCR = PCR \pm random$$

When the desired type of jitter is defined, click **OK**. This does not cause any changes to the *.trp file. It only defines the changes that will be made when the Calculate command is called.

You can set jitter frequency independent of the PCR rate. To prevent misleading results, only use jitter frequencies less than one-half the PCR frequency. For example, if the PCR rate is 25 per second (period = 0.04 second) then the maximum jitter frequency the user should specify is 12.5 Hz (period = 0.08 second). For an example of a jitter frequency that is too high for the PCR frequency, see Figure 3-1.

NOTE. *The PCR Analysis uses the previous PCR as the reference point to calculate the error in the current PCR. This can cause the error calculation to be misleading for some PCR jitter functions. Specifically, the jitter added by the test system may not be easily interpreted by the PCR analysis display.*

Calculate. Uses the parameters defined by the Definition command to create a new transport stream file with introduced jitter. The Calculate command opens the **Output File** dialog box.

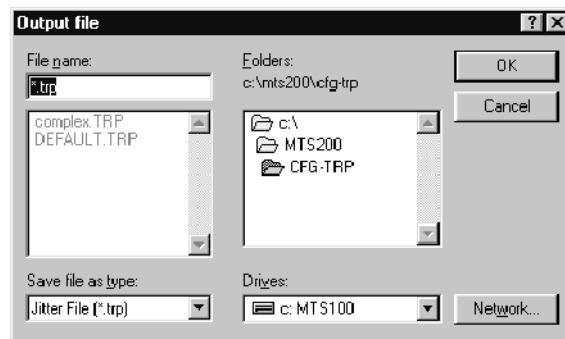

Use this dialog box to name the resulting transport stream file. Enter the desired name in the **File Name** dialog box; the *.trp extension is automatically added.

Once you click **OK**, the jitter calculation begins. There is a status gauge that shows you how far the calculation has progressed. It also shows the type of Jitter

being added and the parameters. The Status Bar also gives information on the calculation.

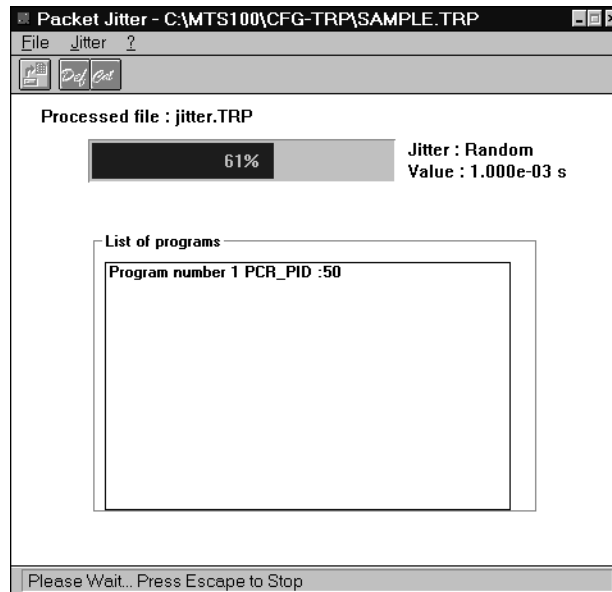
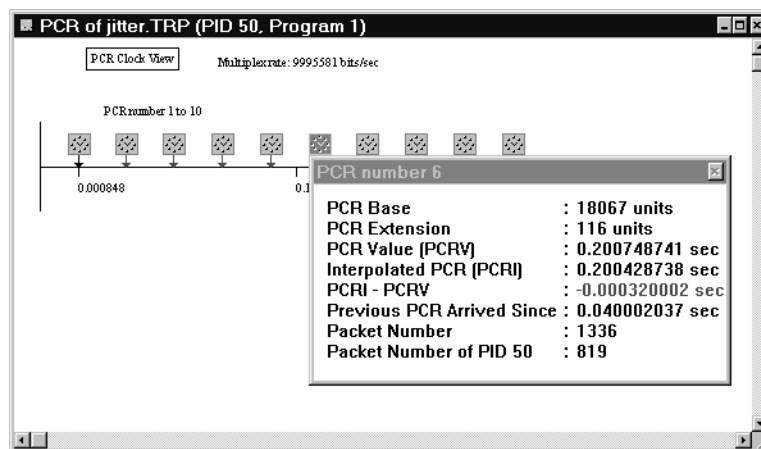

Figure 3-3: The display during jitter calculation

When the calculation is complete, the status gauge reads 100%. The new file can be used as a transport stream file.

The following illustration shows a jitter file with PCRs analyzed by the test system. If you viewed the analysis on screen, most clocks appeared in red, indicating an error.



Help Menu The Help menu commands provide access to the Help system.





Contents. Displays the Help table of contents, index, and find routine.

Using Help. Explains how to use and customize the Help system.

About Jitter Adder. Displays the application version and copyright.

Toolbar

The following commands are available from the toolbar: Open, Definition, and Calculate.

Icon	Name	Function
	Open	Chooses the transport stream file and places its program PID numbers in the <i>List of programs</i> window. (See page 3-193.)
	Definition	Defines the type of packet jitter added to the transport stream file. (see page 3-193.)
	Calculate	Creates a new transport stream file with the defined amounts of jitter added to the PCRs. (see page 3-196.)

Using the DVB Channel Coder/Decoder

The European Digital Broadcasting Project (DVB) specifies a baseline system for satellite broadcasting. The transport stream channel coding portion of the specification has the following flow:

- MPEG-2 Transport stream file (Multiplexer)
- Energy Dispersal — randomizing
- Outer Coder RS (204, 188) — for byte error correction
- Interleaver — better burst error correction
- Inner Coder (Viterbi p/q) — bit error correction
- QPSK Modulator

The DVB Channel Coding and Decoding application also provides decoding to return the coded file to a standard transport stream file.

Table 3-33 lists the type of coding/decoding, the type of input expected, and the resulting file.

Table 3-33: Expected input file types

Operation	Expected input	Output
Energy Dispersal	*.trp	*.eds
Reed-Solomon	*.eds	*.res
Byte Interleaving	*.res	*.inl
Viterbi Encoding	*.inl	*.vtb
Byte Deinterleaving	*.inl	*.din
Reed-Solomon decoding	*.din	*.drs
Energy Dispersal removal	*.drs	*.edr

Starting the Application

Double-click the **DVB channel Coding & Decoding** icon in the **Tektronix MPEG Test System** program group window to start the application. The application window opens as shown below.

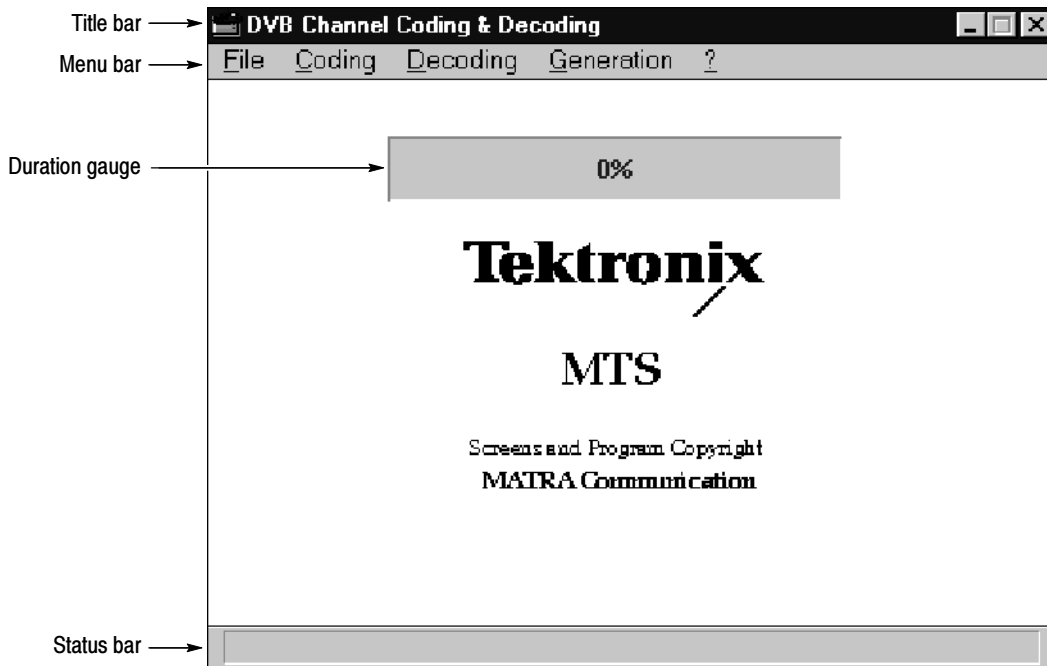

Duration Gauge. Displays the coding or decoding process status in percent.

Menu Commands

Figure 3-34 lists the Jitter Adder menu commands.

Table 3-34: Jitter Adder menu commands

Menu	Commands	Function
File	Quit	Exits the Coder/Decoder application
Coding	Chain	Defines a list of coding modules
	Energy Dispersal	Defines and performs Energy Dispersal coding on a selected file
	Reed-Solomon	Defines and performs Reed-Solomon coding on a selected file
	Interleaver	Defines and performs Interleaver coding on a selected field
	Viterbi	Defines and performs Viterbi coding on a selected file
Decoding	Chain	Defines a string of decoding modules for a file
	DeInterleaver	Decodes a file for Interleaver coding
	Reed-Solomon	Decodes a file for Reed-Solomon coding
	Energy Dispersal Removal	Decodes a file for Energy Dispersal coding
Generation	Pattern	Generates a user-defined repetitive pattern and puts it in a file
	Transport Packet	Generates a user-defined pseudo transport packet and puts it in a file
?	Help	Provides useful information on all the commands and additional information on coding in general
	About...	Displays the application version and copyright

File Menu

The File menu offers the Quit command, which exits the Coder/Decoder application.



Coding Menu

The Coding menu provides access to the required DVB channel coding for satellite broadcasting (Energy Dispersal, Reed-Solomon, Interleaver, and Viterbi). It also provides for chaining the various coding methods together.



Chain. The Chain command opens the **Coding Chain** dialog box, which allows you to create DVB-compliant files.

Each check box defines one module in the coding chain. When all check boxes are selected, the coding will produce a DVB-compliant file. If you deselect any of the check boxes, you will generate a noncompliant file. (This feature is provided for testing purposes.)

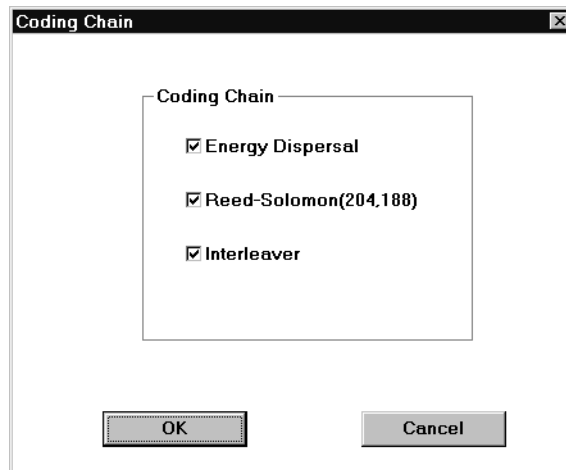

NOTE. If Energy Dispersal is not selected, it is replaced by a “B8 sync byte add only” module in the chain.

When you select **OK**, the **Open** dialog box appears. Identify the file to code.

Although all file types (*.*) are available, the expected transport stream file type for DVB compliance is *.trp. Use a file created by the Multiplexer application or acquire one from a transport stream input through a rear-panel connector.

Select **OK** to initiate the coding process. Each coding module is performed in the order given in the dialog box. During the coding process, a gauge in the

Application Window reports the coding status. The gauge range is 0 to 100% for each type of coding.

NOTE. To stop the coding process at any time, press the **ESC** key. This ends the coding with the current coding module.

The “READY” statement in the status bar indicates that the coding process is complete for the selected modules. There are now three additional files in the original directory with the transport stream file. The new files share the original name with the following extensions: *.eds, *.res, and *.ini.

For more information on individual coding modules, see *Energy Dispersal Coding* on page 3-211, *Reed-Solomon Coding* on page 3-212, and *Convolutional Interleaving Coding* on page 3-212.

Energy Dispersal. The Energy Dispersal command allows you to use this coding scheme alone, instead of in conjunction with the other code modules using the Chain command. This module performs sync byte inversion for the first of each group of eight transport packets, and randomizing of data using a PRBS (Pseudo Random Binary Sequence). For more information on the actual coding, refer to *Energy Dispersal Coding* on page 3-211.

Selecting Energy Dispersal opens the following dialog box.

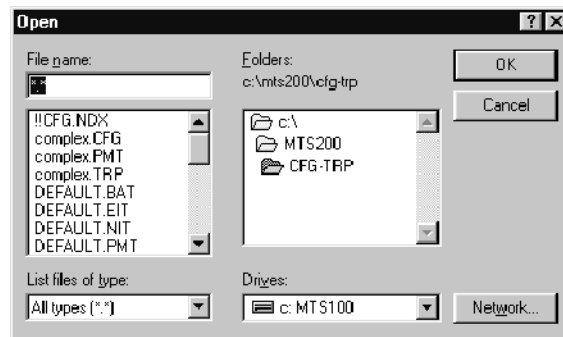

This first byte of the selected input file should be the first byte of a transport stream packet file (the sync byte, 47_{HEX}). The input file should be a *.trp transport stream file. Other file types are permitted, as long as they meet the sync byte requirement, however.

Click **OK** to begin the coding process. A gauge in the Application Window states the coding process status. When the gauge reads 100% and “READY” is displayed in the Status bar, the coding process is complete.

Completion of the coding results in a file with the same base name as the original, except the extension is *.eds.

If you choose a file that is inappropriate for Energy Dispersal, coding will occur anyway. You can stop the coding process at any time by pressing the **ESC** key.

Reed-Solomon. Reed-Solomon coding takes the randomized transport packet (from the Energy Dispersal coding) and adds 16 bytes to the field. (188 initial packet size + 16 bytes of Reed-Solomon = 204 bytes.) For a more detailed explanation of Reed-Solomon coding, see Reed-Solomon Coding on page 3-212.

The **Reed-Solomon** dialog box is displayed after choosing this command. Enter the desired Coded Block Size and Size of Block to Code in the appropriate text boxes. The maximum for both parameters is 255. The default values (204 and 188) are correct values for DVB.

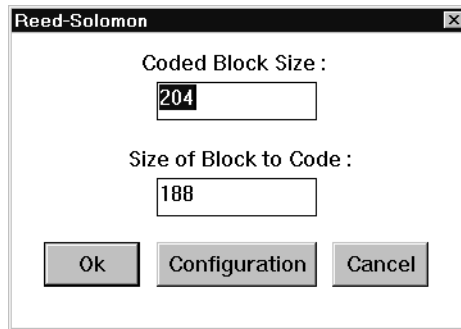

If you choose the **Configuration** command, the **Reed-Solomon Configuration** dialog box appears.

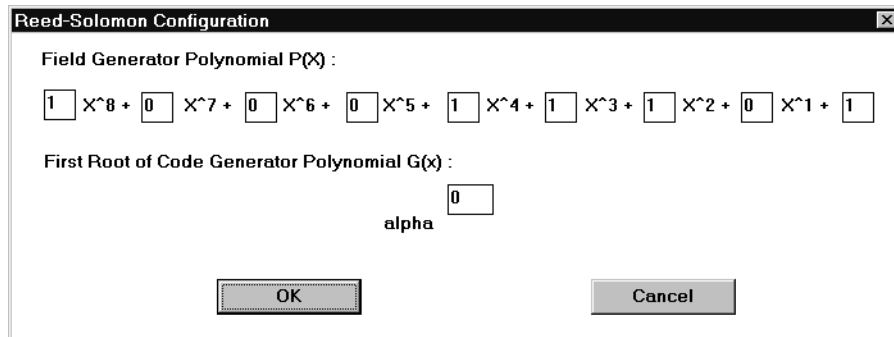

Use the **Reed-Solomon Configuration** dialog box to define different values for $p(x)$ (the Field Generator Polynomial) and α , which is the first root of $p(x)$. The default values are correct for DVB applications.

When the configuration is complete, return to the Reed-Solomon dialog box by selecting **OK**. If you are ready to code a file, select **OK**. This returns the Open dialog box. The coding module accepts *.eds files (previously Energy Dispersal coded) only.

Select a file and enter it in the **File Name** text box; then click **OK**. This initiates the Reed-Solomon coding process. The Application Window gauge tracks the progress of the coding process. When coding is complete, the gauge reads 100% and the Status bar reads **READY**.

The coding process outputs a file with the original name and an added*.res extension.

Interleaver. This module performs convolutional byte interleaving. See page 3-212 for more information on this coding process.

When you choose the **Interleaver** command, the **Open** dialog box appears. There are no parameters to adjust for this coding module.

The Interleaver requires a *.res file (a file previously Reed-Solomon encoded). After selecting a **file to code**, click **OK**. This starts the Interleaver coding module.

A gauge in the Application Window monitors the coding progress. Coding is complete when the gauge reads 100% and the Status bar reads “**READY**.” Interleaver coding results in a file with the same base name as the selected file, except the extension is *.inl.

Viterbi. Viterbi performs inner coding based on the Viterbi punctured convolutional code. For more information on this coding process, refer to *Viterbi Coding* on page 3-213.

NOTE. *This application does not provide a method to decode Viterbi coding.*

When you choose **Viterbi**, the following dialog box appears.

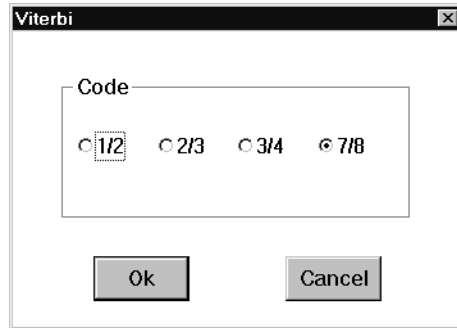

Use the Viterbi dialog box to select the **Viterbi Code**. The code can be 1/2, 2/3, 3/4, or 7/8 (the default is 7/8). When you click **OK**, the **Open** dialog box appears.

Use the **Open** dialog box to select a file for Viterbi coding. The expected file type is an *.inl (Interleaver coding result). Once you select the file, click **OK**. This begins the Viterbi coding process.

A gauge in the Application Window tracks the progress of the coding. The coding is complete when the gauge reads 100% and the Status bar says "READY". The output of this module is a file with the same base name as the original file, but it now has *.vtb as the extension.

Decoding Menu

The Decoding menu provides access to the required DVB Channel Decoding for satellite broadcasting (Deinterleaving, Reed-Solomon Decoding, and Energy Dispersal Removal). It also provides for chaining the various decoding methods together.

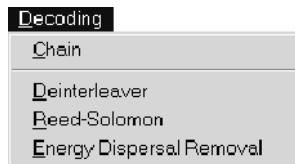

Chain. With the Chain command, you can decode the transport stream file using the DVB-compliant method. The figure below shows the dialog box associated with the Chain command.

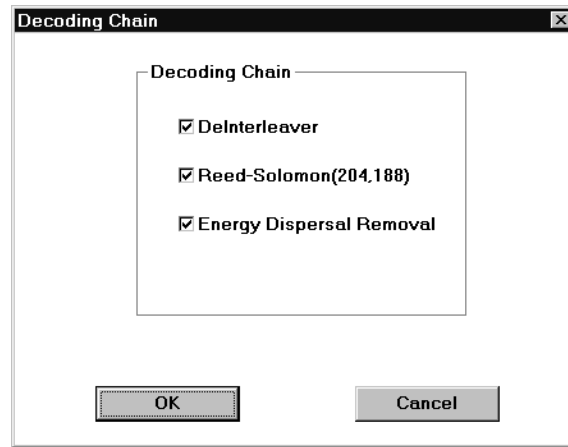

You can deselect any of the check box, however, all boxes must be checked to generate a DVB-compliant file. You purposely deselect modules to create DVB noncompliant files for testing purposes.

Choose **OK** to begin Chain decoding. A gauge in the Application window reports the progress of each decoding operation. All chain decoding is complete when the gauge reads 100% and the status bar says "READY."

If the Energy Dispersal Removal module is not selected, it is replaced by a B8 sync byte removal module in the chain.

To stop the decoding process at any time, press the **ESC** key. This ends the entire decoding chain with the current module.

Deinterleaver. When you choose the Deinterleaver command, the **Open** dialog box appears. The expected input file is one generated by the Interleaver coding module (*.inl), although the Deinterleaver module will accept any file.

When you click **OK**, Deinterleaving begins. A gauge in the Application window reports the decoding process status. Decoding is complete when the gauge reads 100% and the Status bar says "READY". The resulting file has the same name as the original, with the extension *.din added.

To end the decoding at any time, press the **ESC** key.

Reed-Solomon. When you choose the Reed-Solomon command, the **Open** dialog box appears. The expected input file is one generated by the Deinterleaver coding module (*.din).

When you click **OK**, Reed-Solomon decoding begins. A gauge in the Application window tracks the decoding process status. Decoding is complete when the gauge reads 100% and the Status bar says “READY”. The resulting file has the same name as the original, with the extension *.drs.

To end the decoding at any time, press the **ESC** key.

Energy Dispersal Removal. When you choose the Energy Dispersal Removal command, the **Open** box appears. The expected input file is one generated by the Deinterleaver coding module (*.drs), although this decoding module will accept any file type.

When you click **OK**, Energy Dispersal Removal decoding begins. A gauge in the Application window tracks the decoding process status. Decoding is complete when the gauge reads 100% and the Status bar says “READY”. The resulting file has the same name as the original, with the extension, *.edr added.

To end the decoding at any time, press the **ESC** key.

Generation Menu

The Generation menu allows you to create new *.trp files by defining a pattern or transport packets.



Pattern. This command generates a user-defined pattern. When you select the Generation Pattern command, the **Save As** dialog box appears to name the file. A default extension is not provided for the file name. However, if you enter a file name without an extension, *.plp is automatically added.

Click **OK** to confirm the entry and close the dialog box. The **Pattern** entry box appears; enter the number of bytes in the pattern and click **OK**.

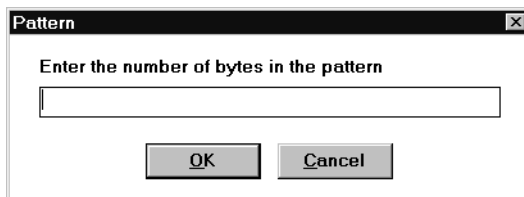

The **Composition Motif** entry box appears to define the repetitive pattern. Enter the desired byte value in hexadecimal. One Composition Motif dialog box appears for each byte you specified in the pattern.

Click OK to confirm the entry and close the dialog box.

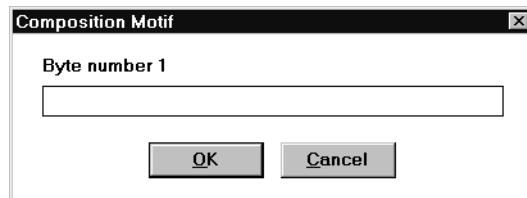

The Pattern entry box appears. Define the number of times you want the pattern to repeat; then click **OK**.

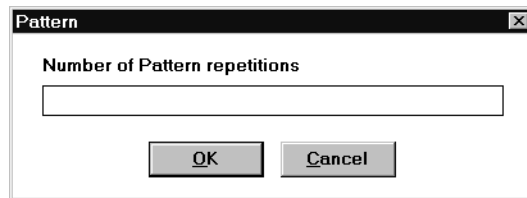

The pattern is created and stored in the file specified above.

Transport Packet. This command generates a repetitive pattern of user-defined transport packets.

When you select the Transport Packet command, The **Transport Packets** dialog box appears to define the payload or to have random data loaded.

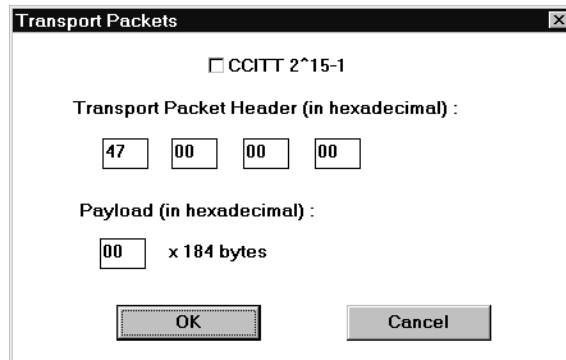

If you choose the CCITT 2¹⁵-1 check box, random data is generated for the payload. If you set the value of the first text box under the Transport Packet Header, the last three text boxes will gray. The default value of the first text box is 47. You can also enter a value.

If the CCITT 2¹⁵-1 check box is not selected, you can define the values of all text boxes under the Transport Packet Header. The default value is 47 00 00 00. You must define the payload, which is then repeated 184 times. Click **OK** to confirm the selections.

The **Number of Packets** dialog box appears.

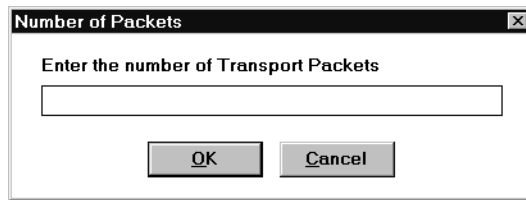

Enter the number of transport packets in the transport stream; then click **OK**. The **Save As** dialog box opens to name the file. A default extension is not provided for the file name. However, if you enter a file name without an extension, *.plp is automatically added.

Click **OK**, the application creates the desired transport stream file. When the Gauge reads 100%, the transport stream file is complete.

Help Menu

The Help menu commands provide access to the Help system.



Help. Provides access to the application Help system.

About MPEG2 DVB Channel Coder and Decoder. Displays the application version and copyright.

Coding Types

This section defines the application coding types.

Energy Dispersal Coding

This is the first coding module and last decoding module.

The input of this coding module is an MPEG-2 transport stream, which is a concatenation of packets of 188 bytes (1 sync byte plus 187 data bytes).

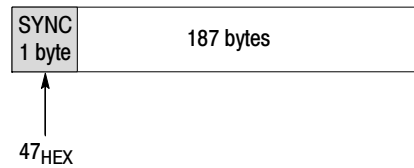

To comply with DVB and ensure adequate binary transitions, the data from the MPEG-2 multiplex (transport stream file) is scrambled with a Pseudo Random Binary Sequence (PRBS). The processing order at the transmitting side always starts from the Most Significant Bit (MSB) of the synchronization byte (0 of 01000111).

The polynomial for the PRBS generation is : $X^{15} + X^{14} + 1$. It uses the 15-bit shift register illustrated below for scrambling and descrambling (in the channel coding process).

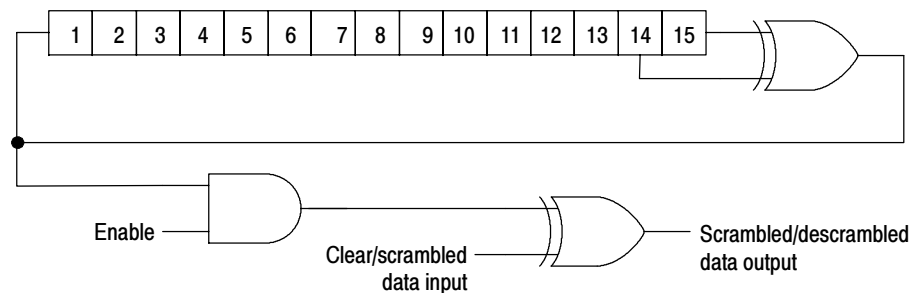

At the start of every eighth transport packet, the sequence 100101010000000 loads into the shift register. This provides an initialization signal for the descrambler. The MPEG-2 sync byte (for the first transport packet in the group of eight packets) is then inverted bit-wise from 47_{hex} to $B8_{\text{hex}}$. The first bit at the output of the PRBS generator is applied to the first bit (MSB) of the first byte following the inverted MPEG-2 sync byte ($B8_{\text{hex}}$).

To optimize synchronization of the subsequent seven transport packets, PRSB generation continues with its output disabled, leaving these bytes unrandomized. Thus the period of the PRSB sequence is 1503 bytes as shown below.

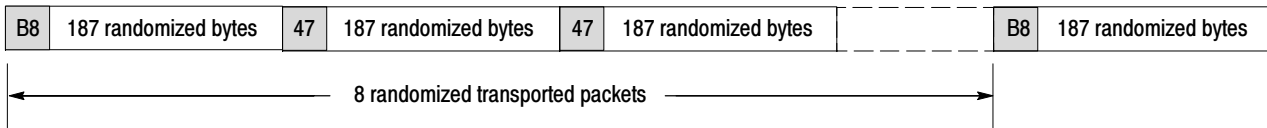

Reed-Solomon Coding

The Reed-Solomon RS (204, 188) code corrects up to 8 bytes in a 204 byte block. This module takes each randomized transport packet at the output of the Energy dispersal module and produces 204 bytes by calculating and adding 16 bytes at the end of the packet (188 bytes).

The Reed-Solomon calculates in a Gallois Field generated by the polynomial:

$$p(x) = x^8 + x^4 + x^3 + x^2 + 1$$

The RS code generator polynomial (used for the 16 byte calculation) is:

$$g(x) = (x + \alpha^0)(x + \alpha^1)...(x + \alpha^{15})$$

where $\alpha = 02_{\text{hex}}$

The RS (204,188), shortened code from the original RS (255,239), is implemented by adding 51 bytes, all set to zero, before the information bytes (a transport packet) at the input of an RS (255, 239) encoder. After the RS coding procedure, these null bytes are discarded, and the transport packet remains as shown in the following illustration.

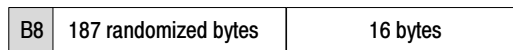

Convolutional Interleaving Coding

Convolutional Interleaving, with depth I = 12, is applied to the error protected packets. The following is a conceptual diagram of the Interleaver.

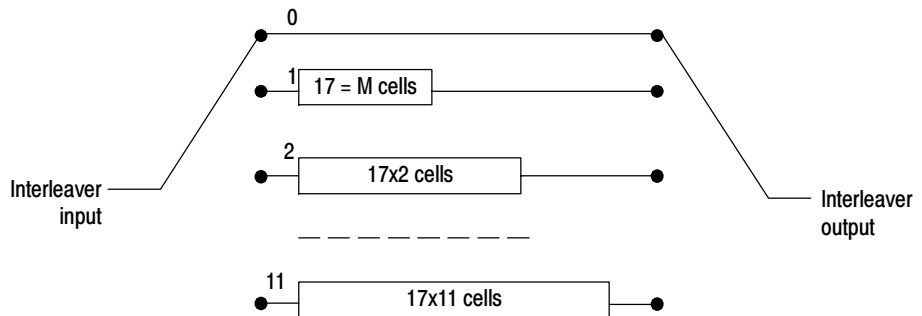

The Interleaver has 12 branches, cyclically connected to the input byte-stream by the input switch. Each branch is a FIFO shift register, with depth (MJ) cells.

- where $M = 17$ or N/I
- $N = 204$ the error protected frame length
- $I = 12$ the interleaving depth
- $J =$ branch index

The cells of the FIFO contain 1 byte, and the input and output switches are synchronized.

For synchronization purposes, the sync bytes and the inverted sync bytes are always routed in the branch “0” of the Interleaver (corresponding to a null delay).

The Deinterleaver is similar to the Interleaver, but the branch indexes are reversed ($j = 0$ corresponds to the largest delay). The deinterleaver synchronization can be carried out by routing the first recognized sync byte in the “0” branch. The following diagram shows the interleaved transport packets.

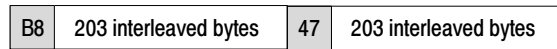

Viterbi Coding

The inner coding is based on a Viterbi punctured convolutional code as diagrammed below.

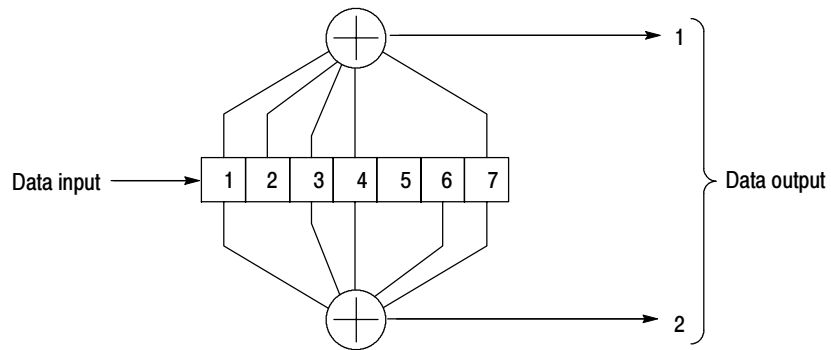

Each byte of the input stream (MSB first) loads in a 7 ($K = 7$, constant length) bit shift register. It then executes two polynomial operations. To produce a p/q code (q output bits for p input bits) a puncture is applied to the output of the $1/2$ coder.

For example, in $7/8$ mode, 7 bits produce 14 bits of $1/2$ code and only 8 are transmitted. (The puncture pattern for $7/8$ is 11010101100110.)

Using the TMCC Stream Combiner

Transmission and Multiplexing Configuration Control (TMCC) data is used to inform receivers of the various modulation schemes and transport stream IDs used in the multiplex.

The MTS300 TMCC Combiner (MTS300 Option TM or MTS3FTM) is a wizard that guides you through creating single- and multiple-stream transport stream files for ISDB-S environments. Inputs to the TMCC Combiner are shown below:

- An MPEG-2 transport stream file (188- or 204-byte packet) is used to create single-transport stream files with TMCC information (S_TMCC files).

When used to create S_TMCC transport stream files, the TMCC Combiner inserts TMCC basic information (consistent with the ISDB-S standard) into the Reed-Solomon area of the 204-byte packets that are the TMCC Combiner output.

- From one to eight S_TMCC files are used to create multiple-transport stream files with TMCC information (M_TMCC files).

When used to create M_TMCC transport stream files, the TMCC Combiner extracts the TMCC data from the S_TMCC files and reprocesses it, creating the 48-byte TMCC data specified in the ISDB-S standards.

For more detailed information about TMCC data and the structure of frames and superframes, see the ISDB-S ITU-R standards documents.

Limitations. Note the following limitations for using the MTS300 TMCC Combiner:

- Valid input for generating an S_TMCC transport stream file is a valid MPEG-2 transport stream file (*.trp file)
- Valid inputs for generating an M_TMCC transport stream file are from one to eight S_TMCC transport stream files (*.trp file)

Minimum PC requirements. Note the following minimum requirements for installing and using the MTS300 TMCC Combiner on a PC:

- 400 MHz Pentium II processor
- 256 MB of memory
- 140 MB free disk space
- Windows NT version 4.0 with Service Pack 5 or above

TMCC Information

This section briefly describes the TMCC information inserted by the MTS300 TMCC Combiner. The information is different for TMCC Basic (S_TMCC) and TMCC Data (M_TMCC) streams.

TMCC Basic Information (S_TMCC Stream)

Table 3-35 lists the contents of the basic TMCC information inserted by the TMCC Combiner when generating S_TMCC transport streams. The fields are described following the listing.

Table 3-35: TMCC basic information fields

S_TMCC data		Bits (64 total)
ID information		8
	Extended data	4
	Alarm signal	1
	Update indication	1
	Transmission frame id	1
	Super frame id	1
Transmission mode and slot information		40
	Transmission mode 1	4
	Number of slots for transmission mode 1	6
	Transmission mode 2	4
	Number of slots for transmission mode 2	6
	Transmission mode 3	4
	Number of slots for transmission mode 3	6
	Transmission mode 4	4
	Number of slots for transmission mode 4	6
Transport stream ID		16

- The extended data field is used to signal extended information.
- The alarm signal field is set to one to indicate alarm status.
- The update indication field is set to one to indicate that TMCC data has changed.
- The super frame ID field is set to one when the current packet is the first packet of the super frame.

- The transmission frame ID field is set to one when the current packet is the first packet of the frame.
- The transmission mode field is used to signal the transmission parameters for the modulation scheme and coding rate.
- The number of slots for the transmission mode is used to indicate how many slots are processed with a particular transmission mode. The total number of slots must be less than 48.
- The transport stream ID is the sixteen-bit ID of the corresponding transport stream.

TMCC Data Information (M_TMCC Stream)

Table 3-36 lists the contents of the TMCC information inserted by the TMCC Combiner when generating M_TMCC transport streams. Differences between the S_TMCC and M_TMCC fields are discussed following the listing.

Table 3-36: TMCC data information fields

M_TMCC data		Bits (384 bits total)
Update Indication		5
Transmission mode and Slot information		40
	Transmission mode 1	4
	Number of slots for transmission mode 1	6
	Transmission mode 2	4
	Number of slots for transmission mode 2	6
	Transmission mode 3	4
	Number of slots for transmission mode 3	6
	Transmission mode 4	4
	Number of slots for transmission mode 4	6
Relative transport stream and slot information		144
	Relative transport stream number slot 1	3
	Relative transport stream number slot 2	3
	...	
	Relative transport stream number slot 48	3
Relative transport stream and transport stream ID		128
	Transport stream ID for relative transport stream 0	16
	Transport stream ID for relative transport stream 1	16
	...	
	Transport stream ID for relative transport stream 7	16

Table 3-36: TMCC data information fields (Cont.)

M_TMCC data		Bits (384 bits total)
Alarm control		5
	Emergency alarm	1
	Reserved	4
Extended data		62
	Extended data flag	1
	Extended data	61

- The total number of slots defined in an M_TMCC frame must be 48.
- Up to eight S_TMCC transport streams can comprise an M_TMCC transport stream.
- Instead of transmitting transport stream IDs for each slot, a 3-bit relative TS ID is used. The relative IDs are transmitted sequentially from slot one and followed by the eight 16-bit transport stream IDs from 0 to 7.
- The 4-bit alarm control field is reserved for future use and is not defined.
- If the extended data flag is set to one, the following 61 bits are used for extended data. When the flag is zero, all 61 bits are set to one.

Creating TMCC Transport Streams

This section describes each of the TMCC Combiner windows in sequential order. You can use this section as a tutorial to help you become familiar with the combiner. First, you will learn how to create an S_TMCC stream, and then you will then learn how to create an M_TMCC stream using the MTS300 TMCC Combiner.

Common TMCC Combiner buttons (found at the bottom of the windows) are described below:

- Back displays the previous window.
- Next displays the next window in the process.
- Help displays the TMCC Combiner help system.
- Cancel quits the application without making any changes to files on your disk.
- Transition displays another Basic Properties window with which you describe a new configuration of transmission modes and slot information. This button is only available when creating S_TMCC streams.

Starting the TMCC Combiner

- Finish begins the multiplexing process using the information you have input.
- 1. Start the TMCC Combiner by selecting the icon from the Tektronix MPEG Test System program group. The Welcome window is displayed.

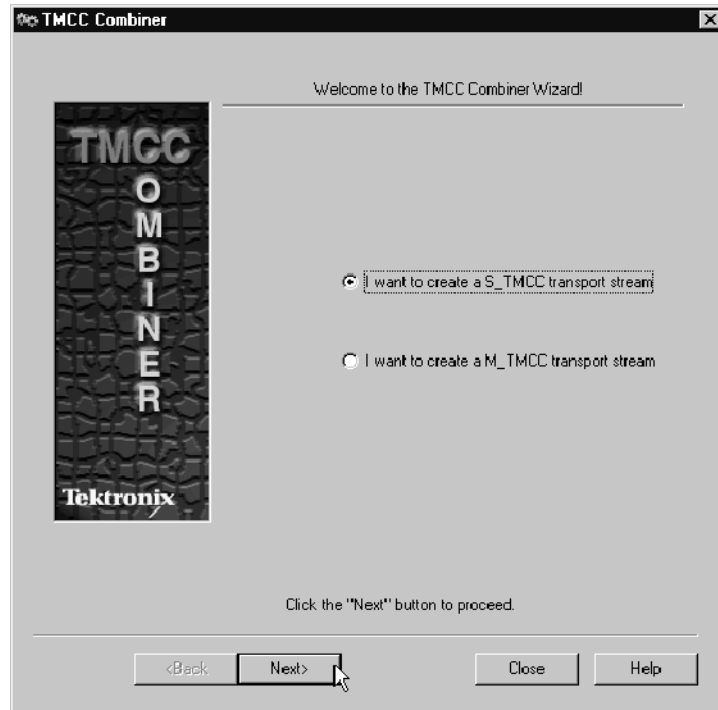

- 2. Select the appropriate option, and then click **Next**.

Specifying Inputs and Outputs

3. If you selected the S_TMCC option, you will see the General Properties window.

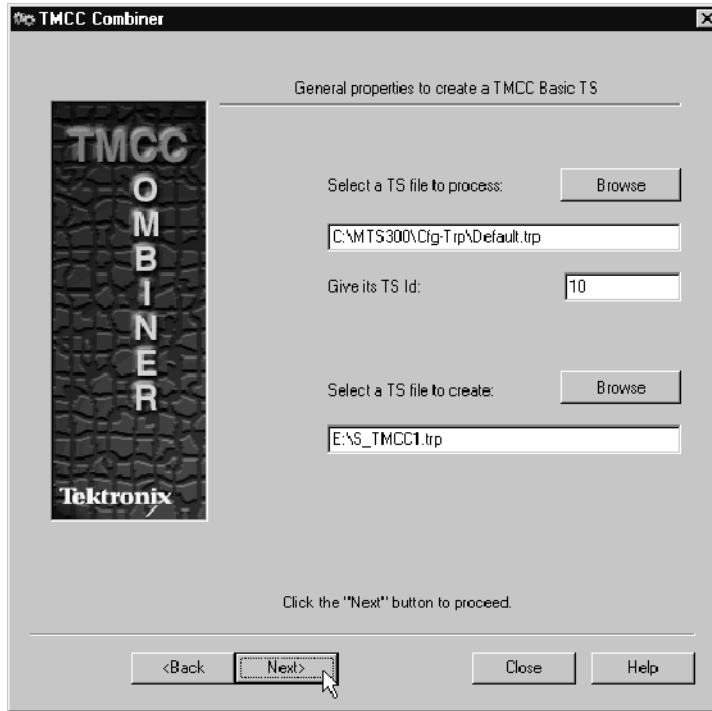

4. Click the upper Browse button to specify the *.trp file (188- or 204-byte packets) to which you will add TMCC basic information. (You can enter the full path to a file on your local PC.)
5. Enter a transport stream ID in the text box provided.
6. Click the lower Browse button to specify a location for the S_TMCC file you will create

NOTE. Remember, these files can be large, so ensure that you have enough disk space for the file. Also, ensure that you have write permission for the file location.

Defining TMCC Properties

7. Click **Next** and the Basic Properties window is displayed.

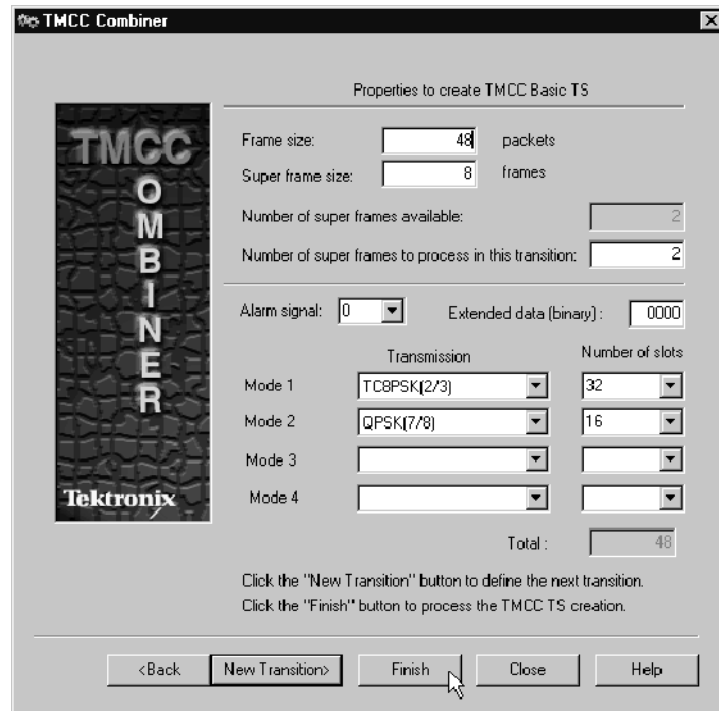

The packets in the input transport stream can be processed with different transmission modes and slot parameters. You define different sets of parameters called transitions. Each subsequent Basic Properties window after the first represents a transition.

NOTE. *The sum of packets processed across all transitions should equal the number of packets available in the input transport stream. If the sum of packets you process is less than the number of packets in the input file, only the packets (up to the total specified) are processed, and the output file is smaller than the input file.*

If the you want to process more packets than there are in the input file, a warning message alerts when you try to generate the transport stream file.

Use the following information to make changes to the Properties window (the elements of the window are described from the top down):

- The frame size text box indicates the number of slots in a frame. This value must be less than or equal to 48. If at least one transition has already been defined, the value of the frame size displayed is the frame size of the last transition.
- The super frame size indicates the number of frames in a super frame. The default value is eight.
- The number of super frames available indicates the number of super frames available in the input file based on the frame size, and is updated each time you change the frame size value.
- The number of super frames to process in this transition has no initial default value. However, if at least one transition has already been defined, then this text box is displayed with a calculated, default value, which is defined as the number of super frames available in the input transport stream less the number of super frames which have already been assigned to a previous transition or transitions.
- The alarm signal has a default value of zero. If set to one, an alarm is indicated and the alarm flag in the TMCC data is set to one.
- The extended data text box represents the 4-bit extended data field (in binary). The default value is 0000.
- The four Transmission selection boxes allow you to choose from among seven modulation modes. You can define up to four different modulation modes for each transition.
- The Number of slots selection boxes allow you to assign the number of slots to each modulation mode.
- The total number of slots used by the the modulation modes (shown at the bottom of the Number of slots column) must equal the frame size.

NOTE. *You cannot define a new transition if the number of super frames already processed is greater than or equal to the number of super frames available in the input.*

If the number of super frames in the current transition (or the sum of the super frames defined previously) is less than the number of super frames available in the input stream, you can define another configuration of modulation modes and slots by clicking the New Transition button.

Generating a TMCC Transport Stream

- After you have defined all of the parameters necessary for your environment, click the Finish button. The TMCC Combiner generates the TMCC basic information, based on your inputs and the values you specified in the Properties windows, and consistent with the ISDB-S/ARIB standards.

The following dialog box is displayed when the process is complete.



After you dismiss the dialog box, initial window of the TMCC Combiner is displayed.

Creating a Multiple Transport Stream TMCC File

Using from one to eight S_TMCC transport stream files, you can create a multiple transport stream multiplex (M_TMCC transport stream).

- Select TMCC Combiner from the Tektronix MPEG Test System program group to start the TMCC Combiner.

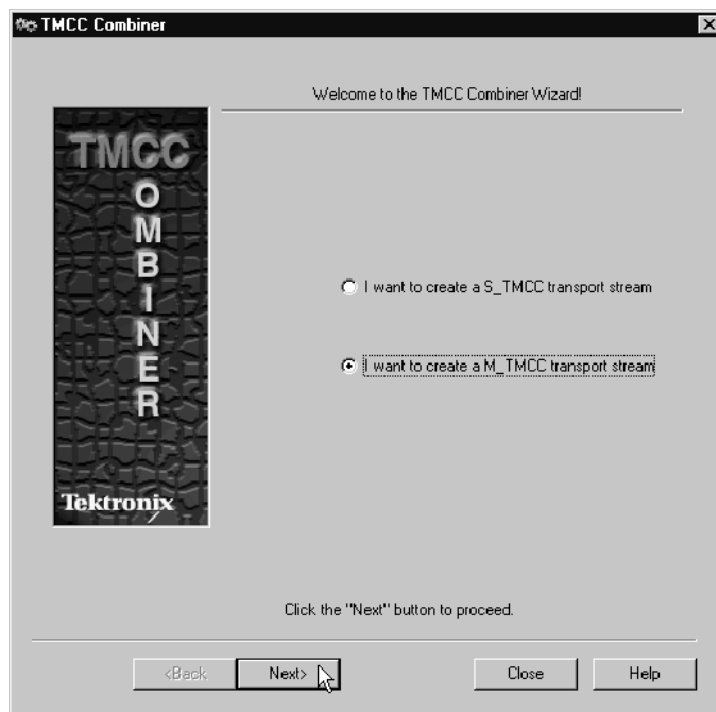

2. Select the M_TMCC option and then click Next to display the Properties window.

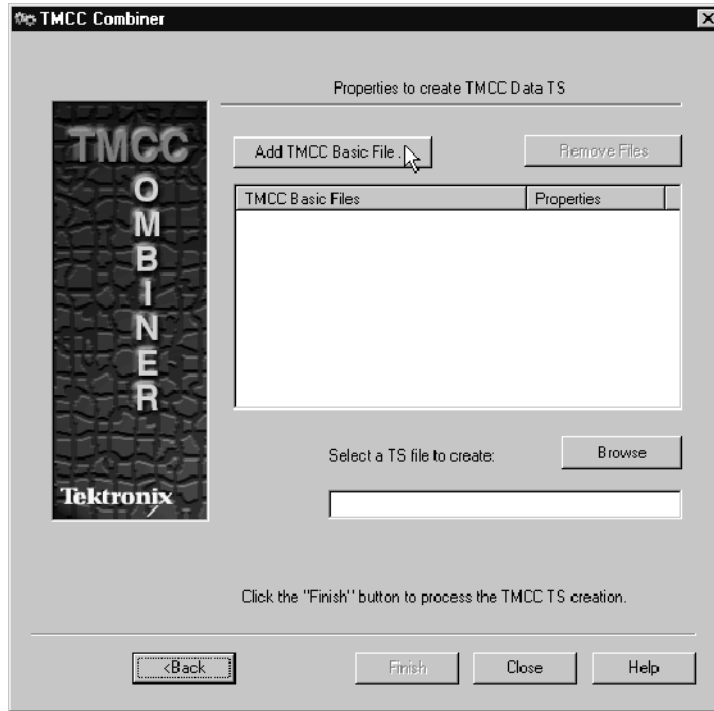

3. Click the Add TMCC Basic file button to specify the S_TMCC transport stream file you will include in the M_TMCC multiplex.

The list box displays both the file name (the full path), and the number of packets in each file.

- Repeat this step to add more transport stream files, up to a total of eight.
- Highlight a transport stream file name and click the Remove File button to remove a file from the configuration.

4. Click the Browse button to specify a location and file name for the output of the TMCC Combiner.
5. When you are finished, click the Finish button.

The 8-byte basic TMCC information from each of the S_TMCC input files is extracted and processed to create the 48-byte TMCC data information used in M_TMCC data streams, according to the ISDB-S/ARIB standards.

6. A message is displayed when the process is complete. After you click OK, the initial TMCC Combiner window is displayed.

Using the Error Injector

You can introduce errors into an MPEG-2 transport stream and use the erroneous stream to stress-test MPEG-2 systems and components with the Error Injector.

The MTS300 Error Injector reads an input transport stream file, modifies selected transport packets according to instructions in the error configuration file (*.EFG file) that you create, and writes the modified stream into another transport stream file. The following illustration shows how the error injector inputs and outputs are related:

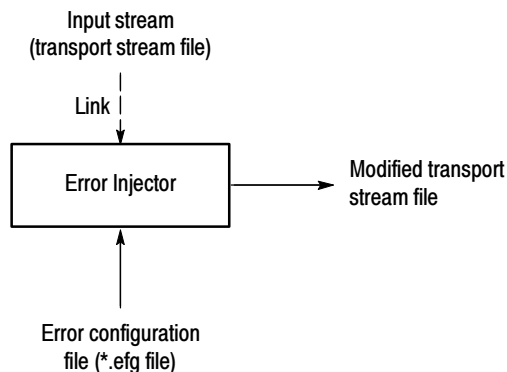

The process for adding errors to a transport stream file is described by the following general procedure:

1. Use the MTS300 MPEG Test System MPEG-2 DVB/ATSC System Analyzer to identify the packet numbers and fields you want to modify.
2. Start the error injector and create an error configuration file (or open an existing file).
3. Edit and save the configuration file.
4. Choose the Multipass option if necessary (see the online help for more information about this option).
5. Generate an output transport stream file.

Error injector configuration files themselves are simply text files into which you enter the following error information:

- Error strings
- Operators, as described below:
 - = Assignment (assigns the error value to the error string field)
 - + Addition (adds the error value to the error string field)
 - – Subtraction (subtracts the error value from the error string field)
 - & Bitwise AND (the output bit is 1 only if the input bit and the offset bit, the error value, are both 1)

For example, if the input byte is 0100 0111 (the value of the sync_byte) and the error value is 0000 1001 (9), the output byte is 0000 0001).
 - | Bitwise OR (the output bit is 1 if either the input bit or the offset bit, the error value, are 1)

For example, if the input byte is 0100 0111 (the value of the sync_byte) and the error value is 0000 1001 (9), the output byte is 0100 1111).
 - ^ Bitwise XOR (the output bit is one if the input bit and the offset bit, the error value, are different; the output bit to zero if the input and offset bits are identical)

For example, if the input byte is 0100 0111 (the value of the sync_byte) and the error value is 0000 1001 (9), the output byte is 0100 1110).
 - ~ Bitwise complement (changes the output bit to the opposite of the input bit)
- Error values
- Packet numbers

NOTE. *Packet numbers are not the same as PID values. Find packet numbers by displaying the PID map in the system analyzer.*

The following list indicates the characteristics of valid error lines in an error configuration file:

- Each error line is one line in the error configuration file.
- There are no spaces or extraneous characters between the error string, operator, and error value.
- All error values are decimal integers.
- One space precedes the list of packet IDs.
- Only commas separate packet numbers in a string of packet numbers.

The following tutorial will illustrate these concepts more fully and will help you become familiar with the basic operation of the error injector.

Error Injector Tutorial

In this tutorial you will learn how to open, edit, and save error configuration files. You will then create a modified transport stream file. As an input stream for this tutorial, you will use the `dvb.trp` file you created in the tutorial, *Creating a Transport Stream File with DVB Information* (see page 2-39).

Creating an Error Configuration File

1. Double-click the **Error Injector** icon in the Tektronix MPEG Test System program group window to start the application. The Error Injector application window is displayed.
2. Select **Open** from the File menu (or click the **Open** command button), and then select **sample1.efg** from the Open dialog box.
3. Click **OK**. The Error Injector Edit window opens with the contents of the `sample1.efg` file displayed as shown in the following illustration.

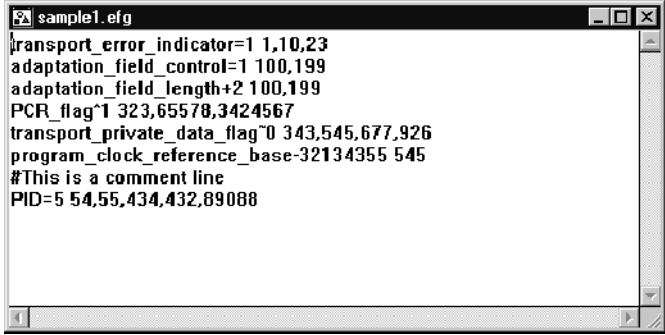

```

sample1.efg
transport_error_indicator=1 1,10,23
adaptation_field_control=1 100,199
adaptation_field_length+2 100,199
PCR_flag^1 323,65578,3424567
transport_private_data_flag^0 343,545,677,926
program_clock_reference_base-32134355 545
#This is a comment line
PID=5 54,55,434,432,89088

```

4. Select **Save as** from the File menu and save the file as `dvberr.efg`.

Edit the Error Configuration File

Normally, before you edit the error configuration file you would identify the packets and fields you want to modify using the MPEG-2 System Analyzer. In this tutorial you will modify the dvb.trp file.

1. Maximize the Edit window. This will make editing the error configuration file easier.
2. Click in the text file, and then select **Delete All** from the Edit menu. This deletes all of the text from the Edit window.
3. Add the following lines of comment:

```
#dvberr.efg  
#dvb.trp input  
#dvberr.trp output
```

NOTE. Note the use of the # symbol to start the comment lines; this symbol must begin all lines of comments in error configuration files. Use this symbol to “comment out” a specific error line without removing it from the error configuration file.

4. Select **Show Error Types** from the Options menu. The Error Types window, shown below, is displayed.



Double-clicking an error in this window adds the text to the line immediately below your cursor in the Edit window. Entering error types this way minimizes problems with misspelled errors in the error configuration file.

5. Double-click the **transport_priority** selection in the Error Types window.
6. Set the cursor at the end of the error line and enter the following bold text:
`transport_priority^1 1,4`
This will change the one-bit transport_priority field from 0 to 1 for the first and fourth packets in the transport stream.
7. Repeat steps 5 and 6 for the error strings in Table 3-37, adding the operators, error values, and packet strings as indicated.

Table 3-37: Error configuration file parameters

Error string	Operator	Error value ¹	Packets ²	Notes
adaptation_field_control	~	1	1,166	Changes the adaptation_field_control field for the packets indicated.
continuity_counter	+	7	1,2	Adds 7 to value the continuity_counter for the first and second packets.
program_clock_reference_extension	^	240	4	Changes the program_clock_reference_extension field to 70 for the first video packet.
sync_byte	&	9	269,4323,4	Changes the sync_byte to 1 for the indicated packets.
PID	=	5	1	Assigns 5 to the PID of packet 1.

¹ Use a space after this value in the error configuration file

² No spaces between these integers and commas in the error configuration file

8. Dismiss the Error Type selection window, and then select **Save Config** from the File menu (or click the **Save** command button).

The error configuration file should look similar to the following illustration. Note that you can use empty lines between error lines to make reading the error configuration file easier.

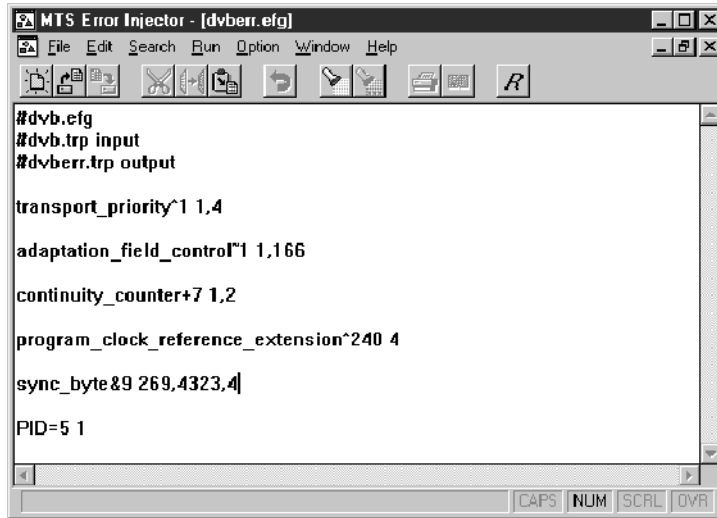

Generate an Output Transport Stream File

Using the following procedure you will generate a transport stream with the errors you have just specified.

1. Select **Start** from the Run menu (or click the **R**, Save and Start, command button). The Start Injection Engine dialog box is displayed with the name of the error configuration file displayed in the Configuration box.

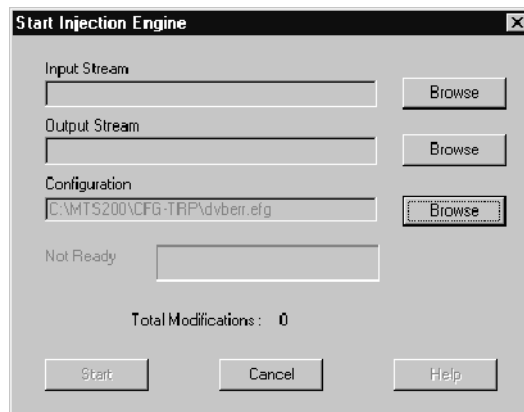

2. Click the top **Browse** button to open a standard Window Open dialog box.
3. Select **dvb.trp** as the Input Stream. The Start Injection Engine dialog box changes to show the total number of packets in the selected transport stream.

4. Click the Output Stream **Browse** button.
5. In the Open dialog box, type `dvberr.trp`, which will be the name of the modified transport stream file you will generate.

NOTE. Include the three-letter file name extension, `.trp`, when you enter the file name for the output stream. The injector does not add the extension to file names.

Once the output stream is identified, the dialog box changes to show that you are ready to generate a modified transport stream.

6. Click **Start** and the dialog box changes indicating that the error injector is running. The number of modifications made to the transport stream file is reported dynamically below the progress bar display.
7. To pause the injector, click **Cancel**, and then use one of the following techniques:
 - Click **Continue** to resume creating the modified transport stream file.
 - Click **Cancel** again to stop the injector and dismiss the dialog box.

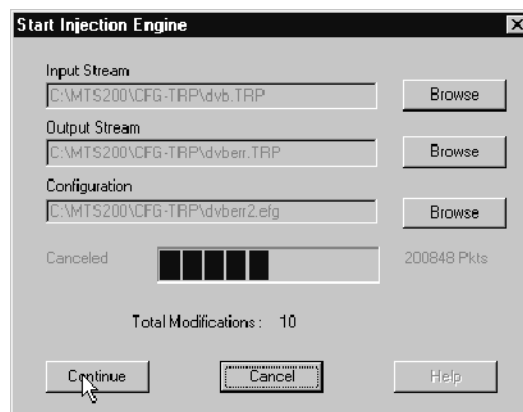

The time it takes to modify the transport stream depends on the size of the input stream and whether you have selected the Multipass option.

8. Once the error injector has processed the complete transport stream file, the dialog box changes to show that the process is complete. Click **OK** to dismiss the dialog box.

For more information about the Error Injector and how to use it, see the online help.

Using the OpenMux Configuration Client

Overview

The Tektronix MTS300 MPEG Test System real-time multiplexer server and OpenMux Configuration Client allow you to filter multiple MPEG inputs and remultiplex those inputs to generate a new transport stream. The following list shows examples of the tasks you perform using the OpenMux server and client:

- Dynamically manage MPEG-2 PSI, DVB-SI, and ATSC PSIP tables
- Remultiplex single and multiple program transport stream files
- Generate single or multiple program transport streams
- Dynamically allocate and filter PIDs
- Restamp PCRs

The Real-Time Multiplexer

The MTS300 OpenMux is actually two separate applications:

- The MTS300 Real-Time Multiplexer server (called the real-time multiplexer server) is the engine that combines the inputs you specify to produce the output you want. This application runs in the background and has no user interface.
- The MTS300 OpenMux Configuration Client application (called the OpenMux) allows you to set broadcast environments (MPEG-2, DVB, or ATSC), define automatic configuration parameters, specify inputs and outputs to a multiplexer server, and monitor the status of the inputs and outputs.

NOTE. *The sources of the inputs can be local or remote to the real-time multiplexer, but must be local to the multiplexer server.*

Multiplexer Inputs

The real-time multiplexer uses the following MPEG structures for inputs:

- Single program transport stream (SPTS) files
- Multiple program transport streams (MPTS) files
- Elementary stream files (MPEG-2 audio and video, and AC-3 audio)

Multiplexer Outputs

The OpenMux generates an output transport stream that you can use to test your MPEG system components, or, using the Stream Recorder application, you can capture the output and write it directly to the local disks for future use. With the OpenMux, you can specify the following parameters for the transport stream:

- Multiplex rate (system processor dependant, see Table 3-38)
- Output stream environment (MPEG, DVB, ATSC)
- Output properties including ASI byte or packet format and M2S

Multiplexer Limits

Table 3-38 indicates the limits of the listed parameters for the OpenMux:

Table 3-38: Real-time multiplexer limits

Parameter	Limit	Notes
Number of inputs	1 – 26	
Number of PSI-SI-PSIP inputs	1	
Number of transport stream file inputs	0 – 25	Transport stream file inputs can be MPEG-2, DVB, ATSC single or multiple program transport streams.
Number of elementary stream program inputs	0 – 6	A program requires one video elementary stream file input and optionally an audio elementary stream file input (MPEG-2 or AC-3).
Number of outputs	1	
Number of clients (per multiplexer server)	1 – 10	A client is the OpenMux documented in this manual.
Rate	Up to 140 Mbps	

Installing the Real-Time Multiplexer

If you purchased the MTS300 OpenMux as an upgrade to your existing system, use the procedures described in the upgrade instructions. If one or more of the OpenMux program components is corrupt, use the procedures described in *Appendix B: Software Repair* for un-installing and re-installing MTS300 applications and entering the license password.

Enabling the OpenMux Demonstration Period

If you ordered Option OM with your MTS300 system, the OpenMux server starts automatically with the rest of the MPEG Analysis Services, and you can ignore this section. If you did not order Option OM, you can enable the OpenMux server and client application for a thirty day demonstration period at any time using the following procedure. Performing this procedure will also clear the *Failure in socket connection* error message that appears when you try to connect the OpenMux server to the local Server Manager without a valid license password.

NOTE. *Once the demonstration period begins, it lasts for 30 consecutive days and then ends. You cannot start, stop, and restart the demonstration period.*

Also note that the demonstration license enables all MTS300 applications for the same thirty day demonstration period. So, you cannot enable one application for a thirty day period and then enable other applications for a subsequent thirty day period.

1. Double-click the **OpenMux Mode.exe** file located in the C:\MTS300\Bin directory.
2. Click the **Start OpenMux server automatically** option and then click **OK** as shown below.

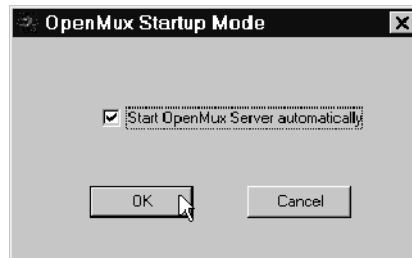

3. Reboot the test system and enter the demonstration license password that shipped with the MTS300 test system when prompted to do so.

Disabling the OpenMux Server Startup

If you enabled the demonstration period for the OpenMux server and you want to remove the message that appears at startup after the demonstration period is over, use the following procedure:

1. Double-click the **OpenMux Mode.exe** file located in the C:\MTS300\Bin directory.
2. Clear the **Start OpenMux server automatically** option and then click **OK**.
3. Reboot the test system.

Starting the Real-time Multiplexer

The OpenMux is started from the Master Client using the following procedure:

1. Start the Master client.
 - a. Double click the Master Client icon in the MPEG Test System program group window.
 - b. Click the **Connect locally** button on the toolbar.

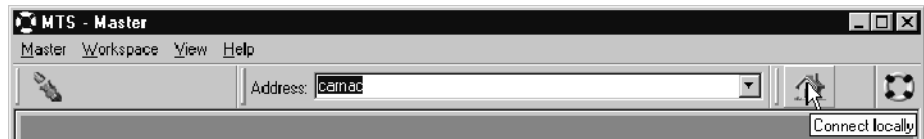

The Master Client display changes showing that you are connected to a Server Manager (in this case the local Server Manager).

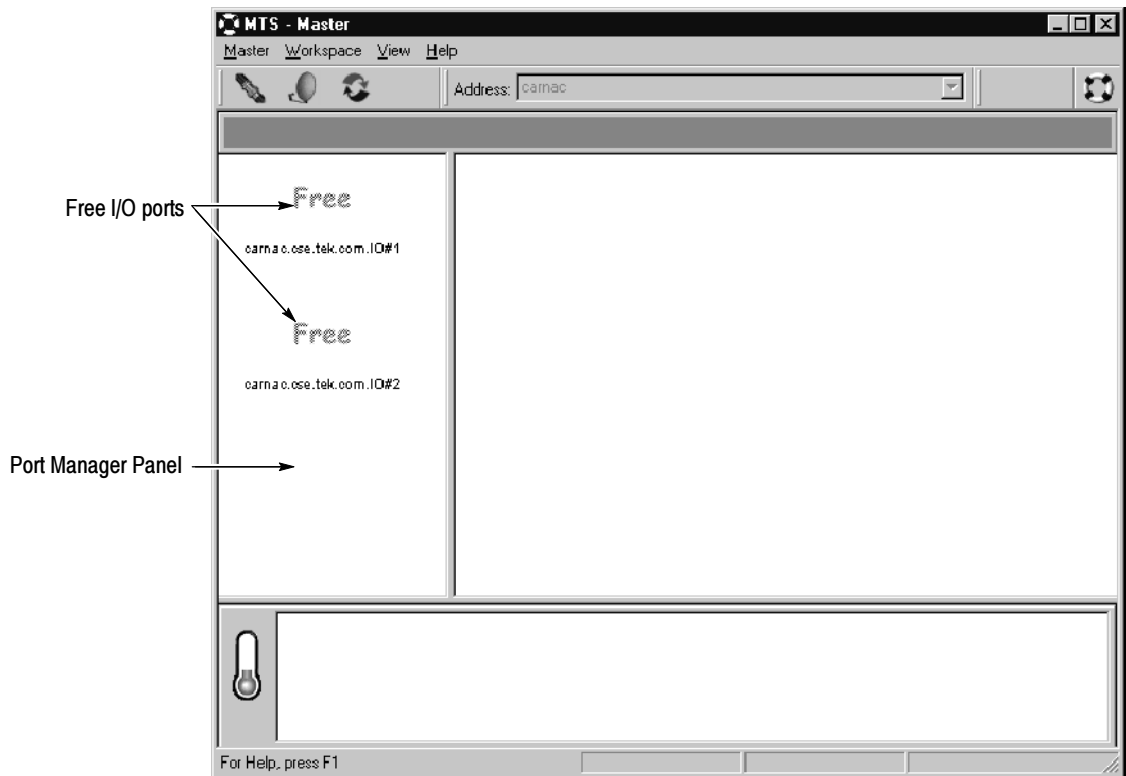

2. In the Master Client Port Manager panel, right click the port from which you will output the transport stream, point to Assign Server in the popup menu, and then select Stream Player from the submenu as shown Figure 2-35.

In the following illustration, the OpenMux server is being assigned to I/O port two.



3. Right-click the server icon in the Port Manager panel, and select **Launch OpenMux Configuration Client** from the popup menu. The OpenMux application is displayed. If you have not saved any configurations, or when the OpenMux is started the first time, the display is blank as shown in the following illustration.



Connecting to an MTS300 Real-Time Multiplexer

Before you can generate a transport stream you need to connect to a multiplexer server, which is the engine that filters your inputs and remultiplexes the output transport stream. You can connect to a multiplexer server running on your local machine, or you can connect to a server running remotely.

NOTE. *The multiplexer server and the OpenMux use standard TCP/IP client/server network communications protocols. See your network administrator for creating the network connections between the multiplexer server and the OpenMux.*

Use the procedure described in step 1 on page 3-240 to connect to a multiplexer server that is running on the same computer as the OpenMux application.

Connecting to a Remote Multiplexer Server. In order to access a remote multiplexer server, follow the procedures in this section.



1. If you are currently connected to a real-time multiplexer server, click the Disconnect button.



2. Click the Connect button and select the real-time multiplexer server as shown in the following illustration.

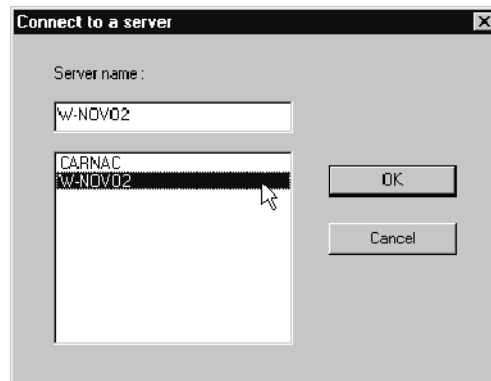

The OpenMux application window changes to display the current configuration of the remote real-time multiplexer server.

Quitting the Real-Time Multiplexer Server and OpenMux Client

To exit the OpenMux configuration client, click the Close box in the title bar of the OpenMux window, and click **OK** in the close confirmation message box.

To stop generating a transport stream and to remove the real-time multiplexer server from the I/O, use the following procedure:

1. In the Master Client Port Manager Panel, right-click the OpenMux icon and select **Stop Mux Generation** from the submenu..



2. Right-click again on the now disabled OpenMux icon and select **Free I/O** from the submenu.



Real-Time Multiplexer Tutorial

In this tutorial you will learn how to set up the OpenMux to create a simple MPEG-2 transport stream with one transport stream input and one program input. The tutorial introduces you to the basic functionality and interface elements of the OpenMux. References to more detailed information are provided throughout the tutorial.

Once the OpenMux is displayed, the basic procedure for creating a transport stream is described in the following list:

- Connect to a local multiplexer server.
- Set the multiplex rate.
- Add an output.
- Add PSI-SI-PSIP inputs.
- Add transport stream and program inputs.
- Start the inputs.
- Start the multiplex.

1. Click the Home button  to connect to the local real-time multiplexer server.
2. The OpenMux Spy view is displayed showing the last saved configuration of the server. The first time the OpenMux Spy View is displayed, the window is blank except for the server icon in the center.

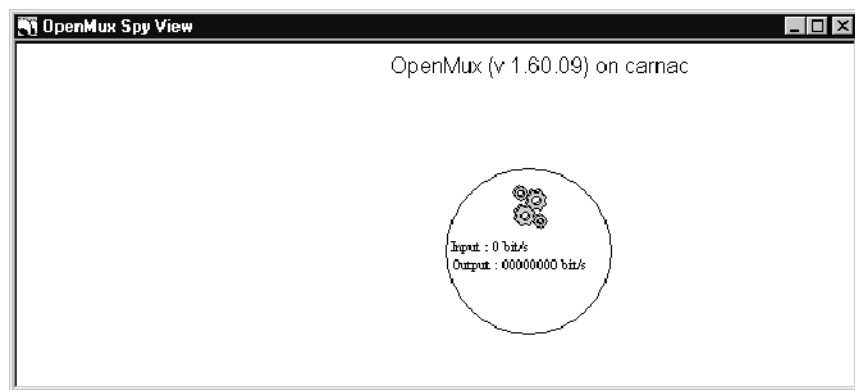

3. Set the multiplex rate to the transport stream you will create:
 - a. Select **Multiplex Rate** from the Multiplex menu.
 - b. Enter a rate in the Multiplex Rate text box. (See Table 3-38 on page 3-234 for multiplex rate limits.)
 - c. Click **OK** and the multiplex rate is updated in the OpenMux Spy view as shown in the following illustration.

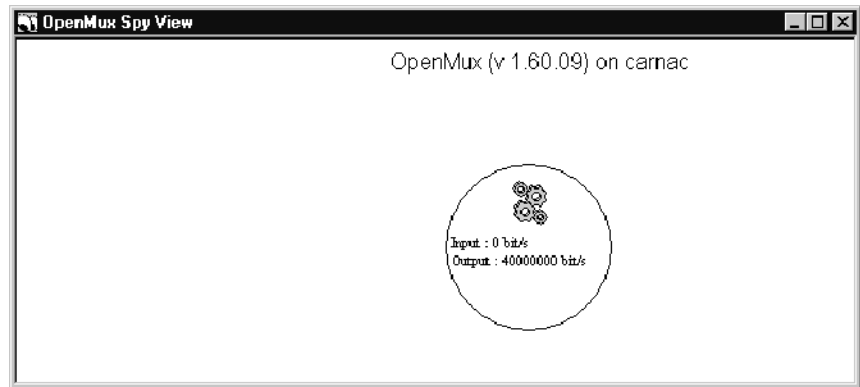

4. Add PSI-SI-PSIP inputs:
 - a. Select **Add Input** from the Input menu, and then select **PSI-SI-PSIP** from the submenu. The Advanced PSI dialog box is displayed. (See *Multiplexer Inputs* on page 3-263 for more information about this dialog box.)

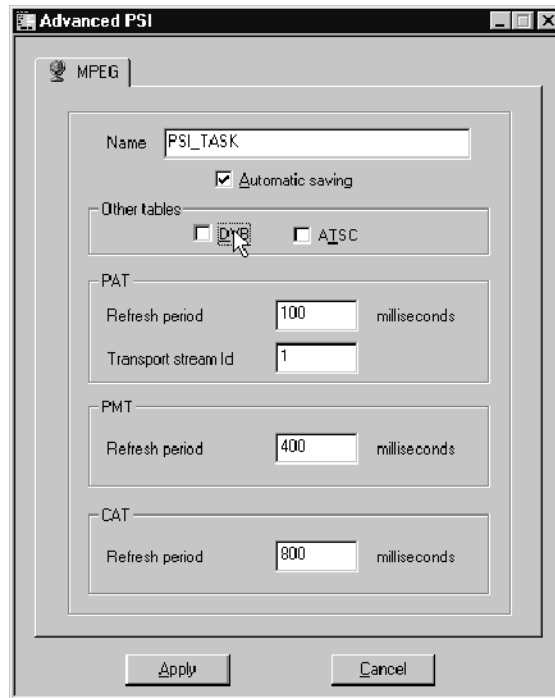

- b. Click the **DVB** check box to remove the checkmark. This hides the DVB tab and will prevent any DVB specific tables in the input from being processed.
- c. Change the values in the Refresh Period text boxes as needed. The default values represent the maximum period (time between packets carrying table data) for each table type based on the MPEG standard.
- d. Change the Transport Stream ID value if necessary. The value in this text box will be the TSID value of the transport stream that you output.
- e. Click **Apply** to accept your changes and close the dialog box. The PSI-SI-PSIP input icon is added to the OpenMux Spy view.

5. Add a transport stream input:
 - a. Select **Transport File** from the Input menu. The Input File dialog box is displayed. (See *Multiplexer Inputs* beginning on page 3-263 for more information about this dialog box.)

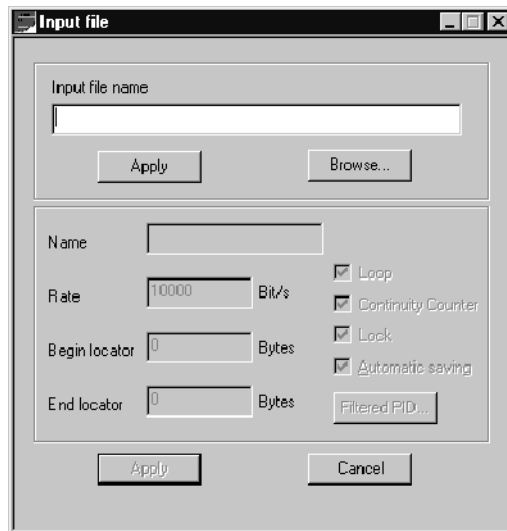

- b. Click **Browse** and use the Windows Open dialog box to select a transport stream file (in this example, *C:\MTS300\CFG-TRP\SAMPLE.TRP*).
 - c. Edit the transport stream parameters as necessary, or accept the default values that have been extracted from the transport stream file.
 - d. Click **Apply** to accept your changes and close the dialog box. A transport stream icon is added to the OpenMux Spy view. (See *Multiplexer Inputs* beginning on page 3-263 for more information about adding and editing inputs using the input icons.)

6. Add program inputs:
 - a. Select **ES Program** from the Input menu. The ES Program dialog box is displayed. (See the procedure on page 3-285 for more information about this dialog box.)

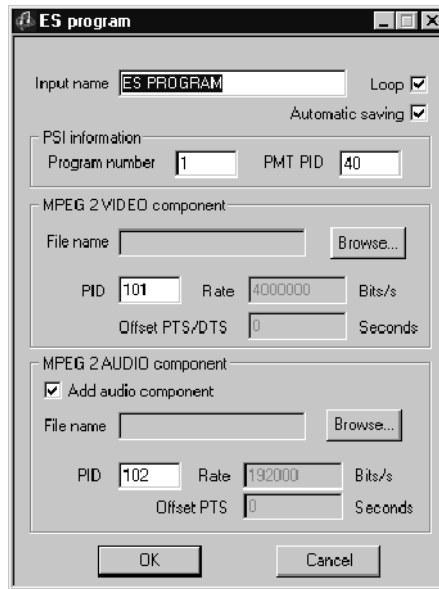

Programs must have at least one video elementary stream. In this tutorial you will add both video and audio elementary stream files. There are a number elementary stream parameters that you can edit after the elementary stream files have been specified. However, for this tutorial you will accept the default PID values, rates, and time stamps extracted from the elementary stream files.

- b. Click **Browse** in the MPEG-2 Video Component group and use the Windows Open dialog box to select a video elementary stream file (in this example, *C:\MTS300\VIDEO\525\MOBL_60.MP2*).
- c. Ensure that the Add Audio Component check box is selected.
- d. Click **Browse** in the MPEG-2 Audio Component group and use the Windows Open dialog box to select an audio elementary stream file (in this example, *C:\MTS300\AUDIO\10KHZ.MP2*).
- e. Click **Apply** to accept your changes and close the dialog box. A program icon is added to the OpenMux Spy view. (See *Multiplexer Inputs* beginning on page 3-263 for more information about adding and editing inputs using the input icons.)

7. Start the inputs:
 - a. Double-click the transport stream icon. The Control view for the input is displayed.

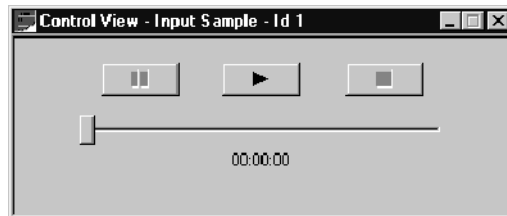

- b. In the Control view, click the ► (Start) button. (You can leave the Control view open or you can close it without affecting the input.)
 - c. Repeat steps a and b for the program input.
8. Start the multiplex selecting **Start Multiplex** from the Multiplex menu (or by clicking the ► (Start Multiplex) button on the toolbar).

The OpenMux Spy view should look similar to the following illustration.

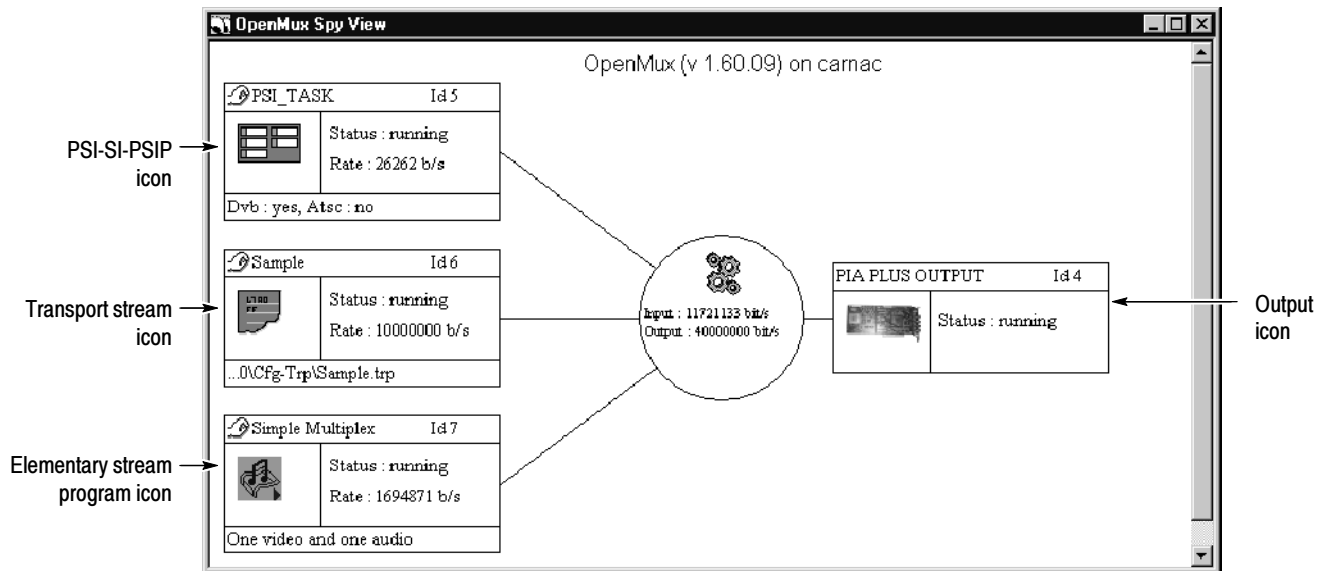

You are now generating a simple transport stream using the inputs you specified.

Multiplexer Windows, Views, and Interface Elements

The MTS300 OpenMux application window provides menus and toolbar command buttons through which you add, edit, delete, and monitor OpenMux inputs and outputs. The inputs and outputs to the multiplexer are visualized using various multiplexer views and icons. This section describes the windows, views, menu selections, command buttons, and icons enabled by the OpenMux.

Multiplexer Application Window

When you first start the MTS300 OpenMux, the application window is displayed. The following illustration shows the application window after you have added the inputs and outputs used in the multiplexer tutorial and are generating a transport stream. The menus and menu selections, toolbar command buttons, and status bar are described in this section.

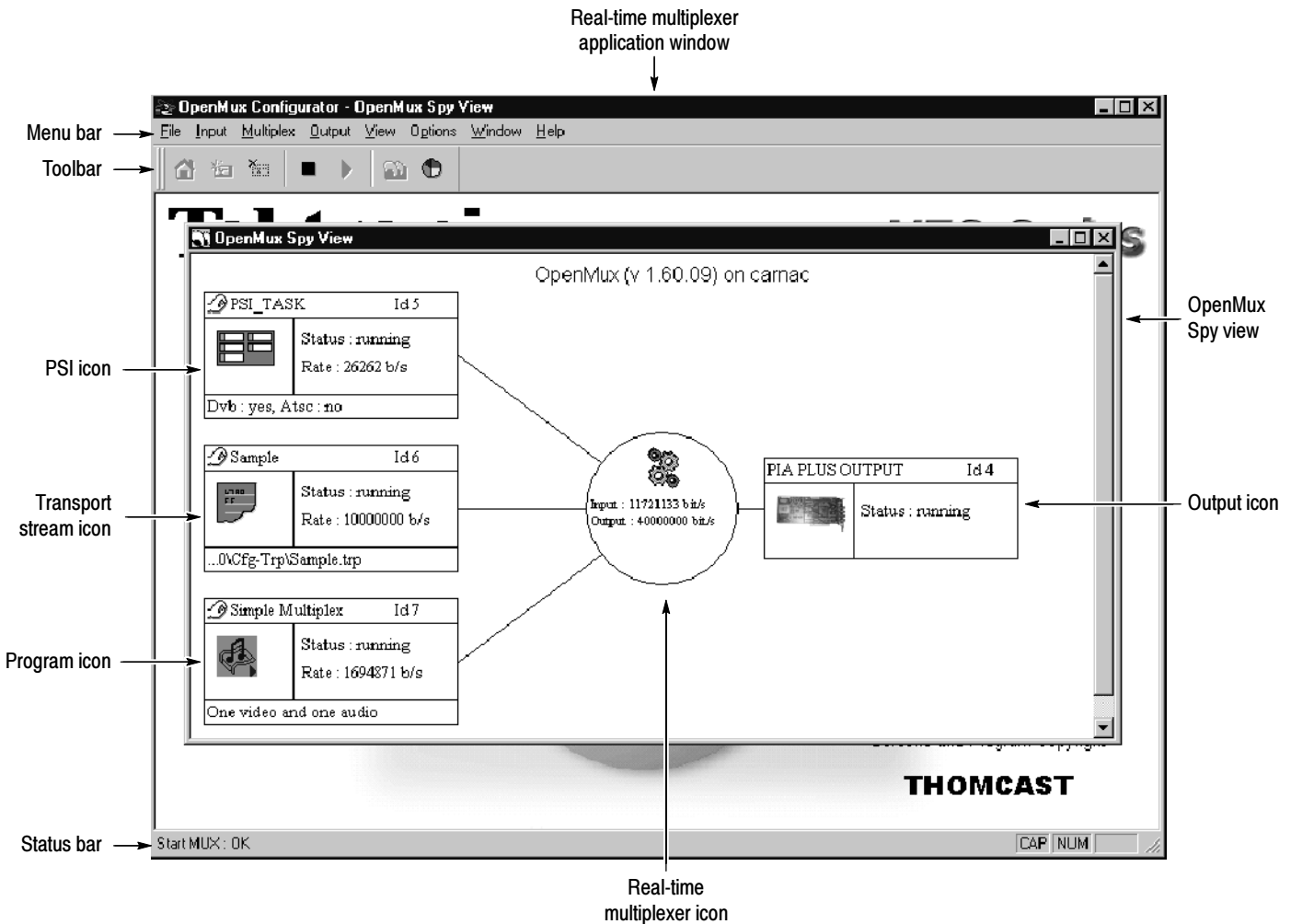

File Menu. Control server connections using the menu selections described in Table 3-39.

Table 3-39: Real-time multiplexer File menu selections

Menu selection	When selected	Comments
Connect	Displays a list of servers.	Select a server with a real-time multiplexer running on it.
Disconnect	Removes the connection to the real-time multiplexer.	
Exit	Quits the real-time multiplexer.	

Input Menu. Add, edit, delete, and monitor the inputs to the OpenMux using the menu selections described in Table 3-40.

Table 3-40: Real-time multiplexer Input menu selections

Menu selection	When selected	Comments
Add Input	Displays the following selections:	
PSI/SI/PSIP	Displays the Advanced PSI dialog box.	Use this dialog box to configure how the OpenMux manages the input PSI-SI-PSIP tables and the tables regenerated in the output stream.
Transport File	Displays the Input File dialog box.	Use this dialog box to select a transport stream file input.
ES Program	Displays the ES Program dialog box.	Use this dialog box to select audio and video elementary stream file inputs.
Input management	Displays a dialog box with a list of input tasks.	Select an input task and click OK to toggle control over an input. You cannot take control of an input managed by another user.
Delete Input	Displays the Delete Input Task dialog box.	Enter an Input ID, select a stop method, and click OK to remove the specified input from the OpenMux.
Delete All Inputs	Removes all inputs to the OpenMux.	
Edit Settings	Displays a dialog box with a list of input tasks.	Select an input task and click OK to display the Edit Settings dialog box for the selected input.

Table 3-40: Real-time multiplexer Input menu selections (Cont.)

Menu selection	When selected	Comments
Control Input	Displays a dialog box with a list of input tasks.	Select an input task from the dialog box and click OK to display the Control view for the selected input.
Hierarchic view	Displays a dialog box with a list of input tasks.	Select an input task from the dialog box and click OK to display the Hierarchic view for the selected input.

Multiplex Menu. Control the status of the OpenMux (off or on) and define the multiplex rate using the menu selections described in Table 3-41.

Table 3-41: Real-time multiplexer Multiplex menu selections

Menu selection	When selected	Comments
Start Multiplex	Starts multiplexing the inputs.	
Stop Multiplex	Stops multiplexing the inputs.	
Multiplex Rate	Displays the Multiplex Rate dialog box.	Specify the multiplex rate in megabits per second (Mbps). See Table 3-38 on page 3-234 for multiplex rate limits.

Output Menu. Add, delete, and monitor the OpenMux output using the menu selections described in Table 3-42.

Table 3-42: Real-time multiplexer Output menu selections

Menu selection	When selected	Comments
Output Properties	Displays the Output Properties dialog box.	This dialog box allows you to name the output and to set ASI format options.
Hierarchic view	Displays the Hierarchic view of the output stream.	This view is available only if the PSI-IS-PSIP input task is present.
Multiplex Allocation Program	Displays the Program Multiplex Allocation view for the output stream.	This view is available only if the PSI-IS-PSIP input task is present.
PID	Displays the PID Multiplex Allocation view for the output stream.	

View Menu. Control whether or not the toolbar and status bar are displayed and refresh the OpenMux Spy view using the menu selections described in Table 3-43.

Table 3-43: Real-time multiplexer View menu selections

Menu selection	When selected	Comments
Refresh (F5)	Refreshes all OpenMux view windows with current data.	
OpenMux Spy View	Displays the OpenMux Spy view for the OpenMux.	
Toolbar	Toggles the display of toolbar on or off.	If checked, the toolbar is displayed.
Status Bar	Toggles the display of status bar on or off.	If checked, the status bar is displayed.

Options Menu. Specify OpenMux Spy view display options using the menu selections described in Table 3-44.

Table 3-44: Real-time multiplexer Options menu selections

Menu selection	When selected	Comments
OM Spy Frequency	Displays the Refresh Frequency dialog box.	Specify the frequency in seconds that data is updated in the OpenMux Spy view.
Automatic Configuration	Displays the Automatic Configuration dialog box.	Use this dialog box to save and apply OpenMux configurations.
Hexadecimal (F2)	Toggles between displaying decimal and hexadecimal values in the Hierarchic views	If checked, hexadecimal values are displayed. Function key F2
Small Size (F3)	Toggles between displaying large or small icons in the OpenMux Spy and Hierarchic views.	If checked, small icons are displayed.
Collapse (F4)	Toggles between showing the Hierarchic view collapsed or expanded.	If checked, the hierarchy is collapsed in the Hierarchic views.
Display	Displays the following selections:	
Basic (F6)	Displays only the essential information in the hierarchic views.	Function key F5

Table 3-44: Real-time multiplexer Options menu selections (Cont.)

Menu selection	When selected	Comments
Partial (F7)	Displays more program information in the hierarchic view.	Function key F5
Total (F8)	Displays the most information in the hierarchic views.	Function key F5
Font	Not available.	

Window Menu. Control how view windows are displayed using the menu selections described in Table 3-45.

Table 3-45: Real-time multiplexer Window menu selections

Menu selection	When selected	Comments
Cascade	Arranges the view windows so that they overlap.	
Tile	Arranges the view windows so that they tile without overlapping.	
Arrange Icons	Arranges the view window icons at the bottom of the application window.	
List of active views	Displays the selected view window.	







Help Menu. Access the online help and version information about the MTS300 OpenMux using the menu selections described in Table 3-46.

Table 3-46: Real-time multiplexer Help menu selections

Menu selection	When selected	Comments
Contents	Displays the MTS300 OpenMux online help.	
Using Help	Displays the Windows NT online help.	
About OpenMux Configurator	Displays version information for the MTS300 OpenMux.	

Toolbar Command Buttons. Table 3-47 lists the command buttons and menu equivalents for the OpenMux.

Table 3-47: Real-time multiplexer toolbar buttons

Button	Button name Menu selection equivalent	When clicked
	Home	Displays the OpenMux Spy view of the local multiplexer server
	Connect File Connect	Displays the Connect to a Server selection list from which you select a machine with a multiplexer server
	Disconnect File Disconnect	Disconnects from the multiplexer server displayed in the OpenMux Spy view
	Stop Multiplex Multiplex Stop Multiplex	Stops the multiplexer server (stops generating a transport stream)
	Start Multiplex Multiplex Start Multiplex	Starts the multiplexer server (starts generating a transport stream)
	Spy View View OpenMux Spy	Opens the OpenMux Spy view window
	Program Multiplex Allocation Output Multiplex Allocation Program	Opens the Program Multiplex Allocation view window

Status Bar. The status bar displays brief messages explaining the highlighted menu selection or the command button over which the cursor is positioned.

OpenMux Spy View

The OpenMux Spy view is the OpenMux view window you use to configure the inputs to the real-time multiplexer server. The top line of each view window indicates the machine name of the multiplexer server to which you are connected (the multiplexer server can be running on a local or remote machine).

If not already displayed, click the Spy view button  on the toolbar to display the OpenMux Spy view.

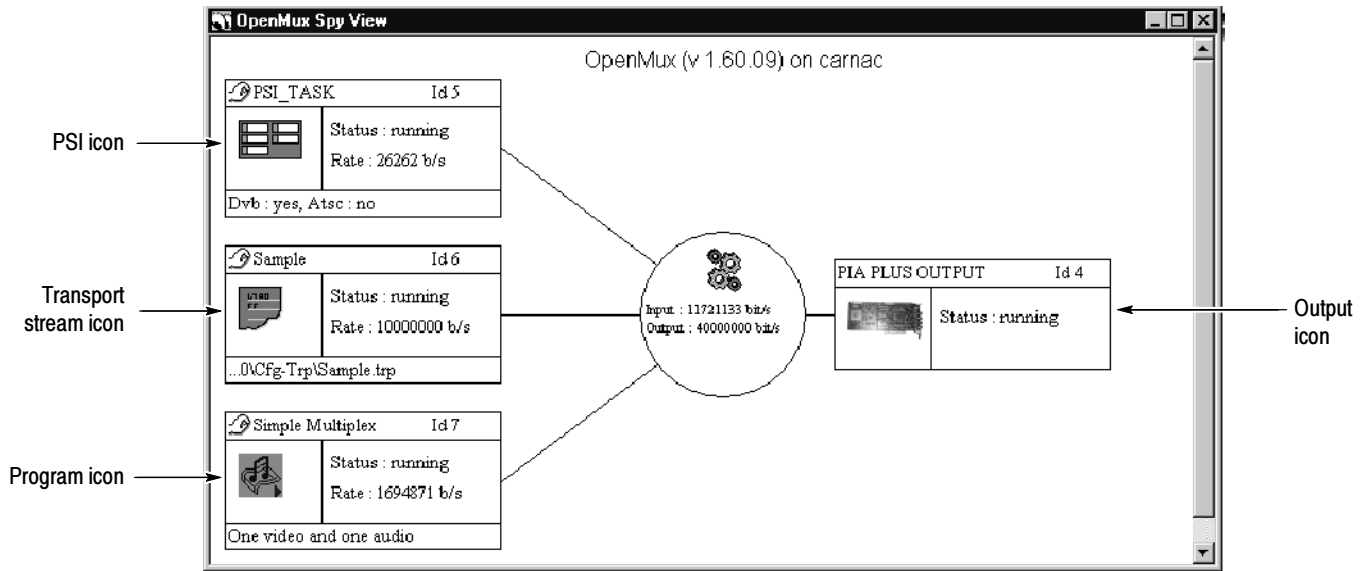



The display shows the current configuration of the multiplexer server. If there is no transport stream being generated by the multiplexer server you are connected to, the OpenMux Spy view is blank, except for the multiplexer icon in the center of the view window.

OpenMux Spy View Icons

The OpenMux Spy view uses icons to represent the input and output to the OpenMux. The icons, and the actions you can perform on them, are described in Table 3-48.

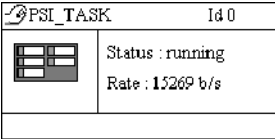
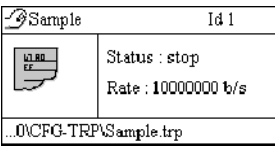
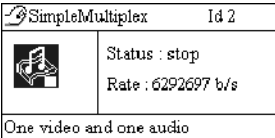
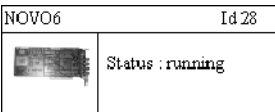
Table 3-48: OpenMux Spy view icons

Icon	Icon name Double-click to	Right-click to
	PSI-SI-PSIP icon	Display a submenu that allows you to see the properties of the task and to manage, edit, or delete the input.
	Transport stream file icon Display the Control view for the input.	Display a submenu that allows you to see the properties of the task, to control, manage, edit, or delete the input, and to view the hierarchy of the input stream.
	Elementary stream program icon Display the Control view for the input.	Display a submenu that allows you to see the properties of the task, to control, manage, or delete the input, and to view the hierarchy of the input.
	Output icon	Display a submenu that allows you to display the hierarchy, program allocation, or PID allocation of the output stream.
	Multiplexer server icon	

Each input icon includes information about the management state of the input in the upper left corner of the icon. See *Managing Multiplexer Inputs* beginning on page 3-263 for more information about this topic.

Input icons provide the following information:

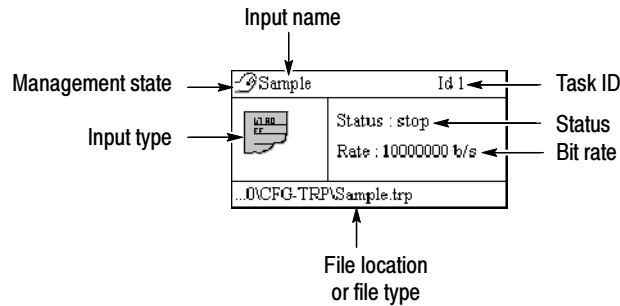

- **Input name.** This name appears in the Multiplex Program Allocation view for the output. For PSI-SI-PSIP and transport stream file inputs, you can edit the input name at any time using the Edit Settings dialog box. For elementary stream program inputs, you need to edit the name when you create the input.
- **Task ID.** The task ID is allocated as inputs are created. The task ID of a new input is incremented one based on the task ID of the previously created input. Task IDs are not dynamically managed; therefore, removing inputs does not change task ID values.
- **Status.** The possible status for each input type is listed in Table 3-49 on page 3-255.

Table 3-49: Icon type image characteristics for each possible input status

Input	Status	Icon image characteristic
PSI-SI-PSIP	Running	Green
Transport File	Running	Green
	Paused	Black and white
	Stopped	Grey
ES Program	Running	Green
	Paused	Reverse video with a ■■ symbol in the image
	Stopped	Reverse video with a ■ symbol in the image
	Underflow	Yellow
	Overflow	Pink
	Error	Red

One state, *start in a few seconds* is a temporary state for inputs: the input is initializing. In this state, the icon is black and white and changes to green as soon as the input status changes to running. If the input is not looped, when the file has been read in to the multiplexer server, the status is *End*. If the connection to the server is lost, input states are *Undefined*.

- Bit rate. The bit rate (given in bits per second) is extracted from transport stream file and elementary stream file program inputs. The bit rate is calculated for PSI-SI-PSIP inputs.
- Management state. The management state options are described in *Managing Multiplexer Inputs* beginning on page 3-263.
- Input type. The input type image reflects whether the input is a PSI-SI-PSIP, Transport File, or ES Program input and changes according to the status of the input as indicated in Table 3-49.
- File location or file type. The file location or file type indicates the source file for transport stream file inputs, and the elementary stream types used for elementary stream program inputs.

Because the PSI-SI-PSIP information is extracted from the transport stream file inputs and managed dynamically by the OpenMux, the PSI-SI-PSIP icon does not include file location or file type information.

Hierarchic Views

The OpenMux uses a Hierarchic views, similar to the Hierarchic views of the table editors and the multiplexer, to show the structure of input and output transport stream elements.

NOTE. *The Hierarchic view for the output stream is available only if the PSI-SI-PSIP input task is present.*

- To display the Hierarchic view of an input or output stream element, right click an input or output icon and then select **Hierarchic View** from the submenu. (This view is not available for PSI-SI-PSIP input tasks.)

Both view windows are displayed at the bottom of the MTS300 OpenMux window. You can select the blue bar to the left of a Hierarchic view window to drag it to a new location.

The following illustration shows the Hierarchic view of an output transport stream.

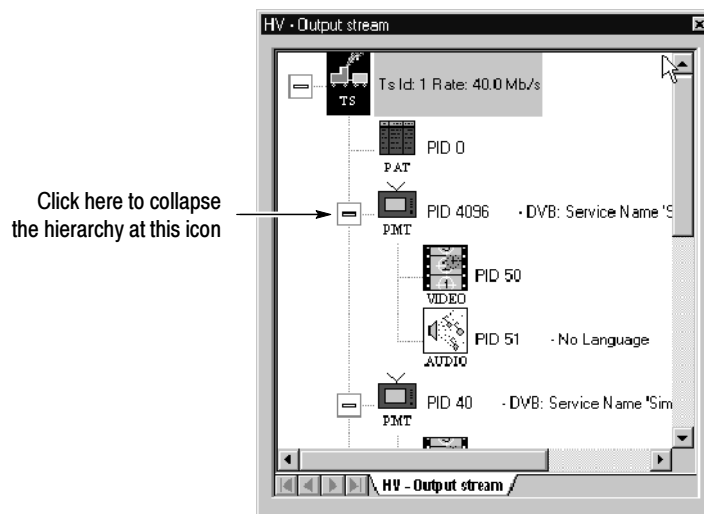

You can expand and collapse the elements by clicking on a box next to an icon with subordinate transport stream elements.

You can display the information presented in the Hierarchic views as small icons by pressing the F3 function key on your keyboard (or by selecting Small Size from the Options menu).

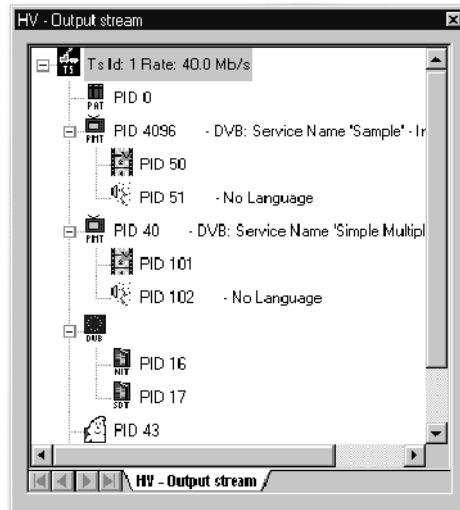

The following illustration shows the input Hierarchic view of a transport stream.

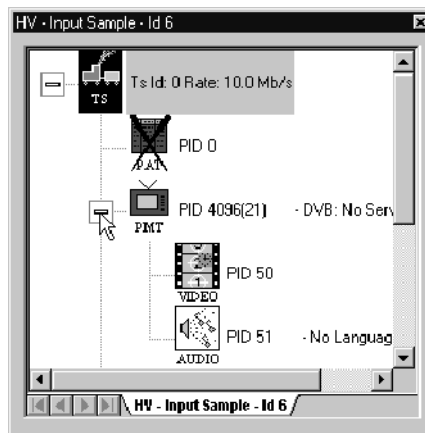

There are two important aspects of this illustration:

- Icons with a cross (X) over them indicate that the elements they represent are excluded in the output stream, or, in the case of PSI, SI, and PSIP tables, are being regenerated by the multiplexer server.
- The program icons (the PMT and elementary stream files) have popup menus associated with them that you can display by right-clicking on an icon. You can use these menus to add, remove, or change program elements.

Multiplex Allocation Views

You can visualize the output transport stream using the Program Multiplex Allocation view and the PID Multiplex Allocation view. Both of these views use a pie chart to depict the percentage of the output transport stream used by the programs or PIDs respectively. Both views are dynamic, and both views allow you to see at a glance the make-up of your transport stream.

Program Multiplex Allocation View. The Multiplex Program Allocation view represents the percentage of the output transport stream used by each program, PSI-SI-PSIP input, and null packets.

NOTE. *The Program Multiplex Allocation view for the output stream is available only if the PSI-SI-PSIP input task is present.*

- To display the Program Multiplex Allocation view, right-click the output icon, and then select **Program Multiplex Allocation** from the submenu. This view window is displayed at the bottom of the MTS300 OpenMux window. You can select the blue bar to the left of a Hierarchic view window to drag it to a new location.

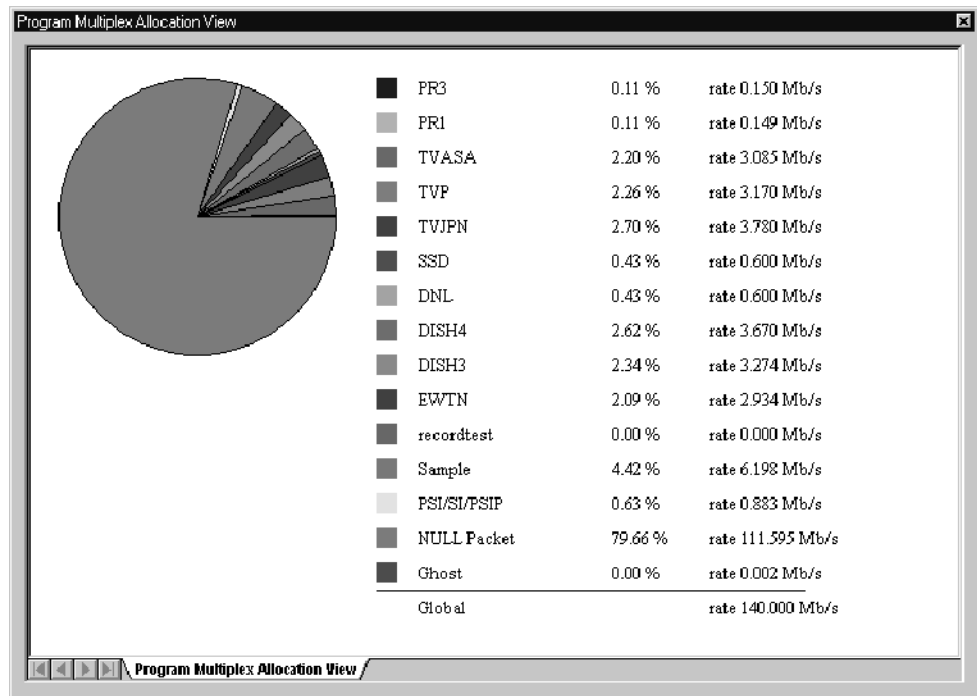

You can resize and reposition this view window to make viewing the contents easier.

PID Multiplex Allocation View. The PID Multiplex Allocation view represents the percentage of the output transport stream used by each PID in the transport stream.

- To display the PID Multiplex Allocation view, right-click the output icon, and then select **PID Multiplex Allocation** from the submenu. This view window is displayed at the bottom of the MTS300 OpenMux window. You can select the blue bar to the left of a Hierarchic view window to drag it to a new location.

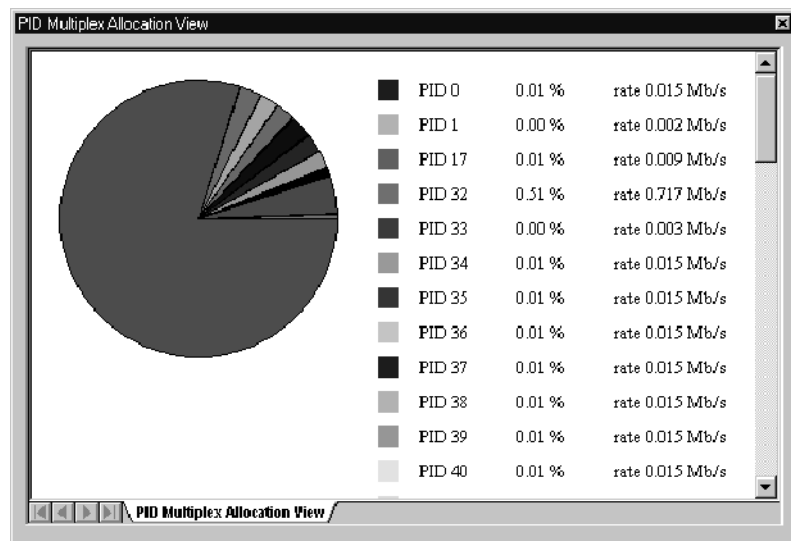

Saving Multiplexer Server Configurations

A configuration is a set of defined inputs and the output multiplex rate applied to a multiplexer server. The current configuration of the multiplexer server is displayed and managed using the OpenMux and the icons in the OpenMux Spy view. Using the procedures described in this section, you can automatically save the displayed configuration and have it appear the next time you restart the multiplexer server. You can also save multiple configurations of one or more multiplexer servers.

NOTE. *When you create, save, or delete configurations, you are specifying the parameters of the multiplexer server (the application running in the background)). If the multiplexer server is being used by another OpenMux, the current status of the inputs and output parameters are displayed in the OpenMux Spy view, regardless of the configuration parameters you may have saved earlier.*

To save a configuration of inputs, outputs, and server connection, use the following procedure:

1. When you add inputs to the OpenMux, ensure that the Automatic Saving check box is selected. When you add inputs (PSI-SI-PSIP, transport stream file, or elementary stream program), this is a default value.

The following illustration shows the Advanced PSI dialog box with the check box selected. After an input is added, you can change this setting for any input you manage, using the Edit Settings dialog box.

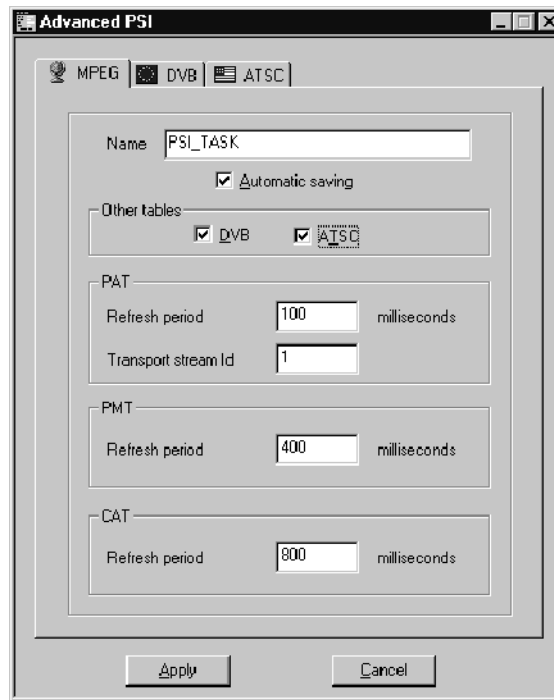

NOTE. For inputs to be saved to a configuration, the Automatic Saving input check box must be selected. If this input option is not selected, when a configuration is created using the input, the input is ignored and will not appear when the configuration is applied.

2. Once you have the configuration of inputs, outputs, and multiplex rate set the way you want, select **Automatic Configuration** from the Options menu. The Automatic Configuration dialog box is displayed.

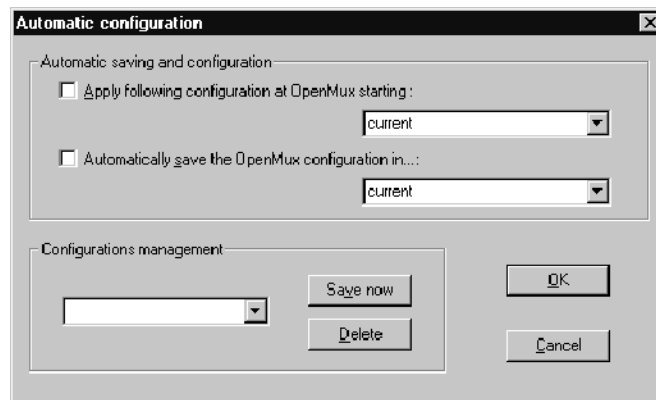

The following list describes each of the options in the Automatic Configuration dialog box and how to use them:

- **Apply Following Configuration at OpenMux Starting.**

If this check box is selected, the configuration listed in the text box will be applied the next time you restart the multiplexer server. If this check box is not selected, no configuration is applied when you restart the multiplexer server.

Select a configuration name from the drop-down list box, or enter a name into the text box. New names are added to the list of configurations available from the drop-down list boxes.

- **Automatically Save the OpenMux Configuration in.**

NOTE. For inputs to be saved to a configuration, the Automatic Saving input check box must be selected. See page 3-261.

If this check box is selected, the multiplexer server configuration displayed when you quit the multiplexer server application is saved into the configuration indicated in the text box. If the check box is not selected, the configuration is not saved.

Select a configuration name from the drop-down list box, or enter a name into the text box. New names are added to the list of configurations available from the drop-down list boxes.

- **Configurations Management.**

- You can save the currently displayed configuration by entering a new configuration name into the text box and clicking the Save Now button.

- You can save the currently displayed configuration into an existing configuration by selecting a configuration name from the drop-down list box and clicking the Save Now button.

- You can delete configurations by selecting a configuration name from the drop-down list box and selecting Delete.

The changes you make to the list of configurations are reflected in the other drop-down list boxes in the dialog box.

3. After you have made the configuration changes you need, click **OK** to accept your changes and close the dialog box. Click **Cancel** to close the dialog box without making any configuration changes.

Multiplexer Inputs

The MTS300 OpenMux allows you to create a transport stream using three different types of inputs. These inputs and how you can work with them are described in the following sections:

- *Managing Multiplexer Inputs.* The management state of an input determines which OpenMux can control the status of the input or remove it from the input. Only the OpenMux that manages an input can make changes to that input. This section describes the concept of input management and provides procedures for releasing and taking management of OpenMux inputs.
- *PSI-SI-PSIP Input.* Specific PSI, SI, and PSIP tables are extracted from the other inputs and modified dynamically by the multiplexer server. This section describes the table types filtered and regenerated by the multiplexer server. The section also provides procedures for adding, modifying, and deleting PSI-SI-PSIP inputs. See page 3-264.
- *Transport Stream File Input.* Transport stream inputs can be any combination of MPEG-2, DVB, or ATSC single or multiple program transport stream files. This section provides procedures for adding, modifying, deleting, controlling, and monitoring transport stream file inputs. See page 3-275.
- *Elementary Stream Program Input.* Each elementary stream program must minimally include an MPEG-2 video elementary stream file and can optionally include an MPEG-2 audio elementary stream file. This section describes how to add this input and lists the error messages associated with creating the input. See page 3-284. Most of the tasks described in *Transport Stream File Input* also apply to the elementary stream program input.

Managing Multiplexer Inputs

Each input icon in the OpenMux Spy view includes information about the management state of the input in the upper left corner of the icon. The management of an input (who controls it) determines which OpenMux can control the status of the input: present, running, paused, or stopped. There are three possible management states as shown in the following illustration (note the differences in the presence of the hand image in the upper left corner of the illustrations).

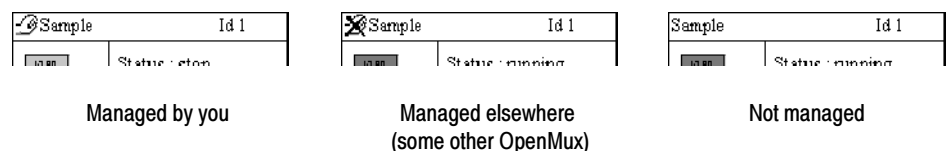

When you create an input, by default you manage that input. If you manage an input, no other OpenMux can control it or remove it as an input. To release management of an input, right-click the icon for the input and select Toggle Management from the submenu.

If an input is not managed (someone has released management of the input), you can take over management using one of the following techniques:

- Right-click the icon for the input you want to manage and select **Toggle Management** from the submenu.
- Select **Input Management** from the Input menu. In the dialog box that is displayed, select the input for which you want to take management, and then click **OK**.
- Right-click the icon in the OpenMux Spy view and select **Edit Settings**. When an Edit Settings dialog box is opened for an un-managed input, management for the input is automatically given to the OpenMux that accessed the input settings.

NOTE. *When an input has an open Control view, you cannot toggle the management for that input. Close the Control view window to toggle management. Also, if the Hierarchic view for the output is displayed, you cannot toggle management of the PSI-SI-PSIP task. Close the Hierarchic view to toggle management.*

PSI-SI-PSIP Input

The PSI-SI-PSIP input is an essential MTS300 OpenMux task if you want to remultiplex multiple inputs. Using the PSI-SI-PSIP input, you can perform the following tasks:

- Configure the PSI-SI-PSIP input task to display the next time you restart to the multiplexer server. Select the Automatic Saving check box shown in the illustration on page 3-265.
- Specify and change the output environment for the output stream. Select any combination of the DVB and ATSC check boxes on the MPEG panel.
- Specify and change the input task name that appears in the Hierarchic view of the output. Enter the name you want in the Name text box on the MPEG panel.
- Specify and change the refresh, or input rate for the tables in the output stream. Change the rates in the table type groups on each panel.
- Specify and change which DVB SI and ATSC PSIP tables are included in the output transport stream. Select the appropriate check boxes on the DVB and ATSC panels.

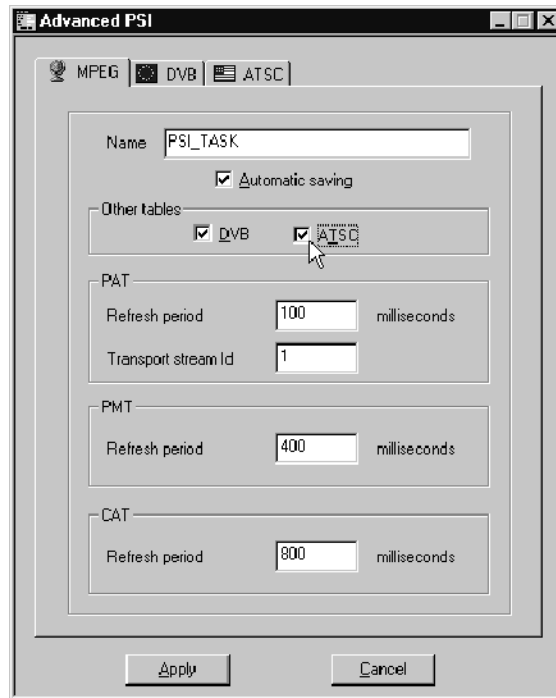

Through this input task, the multiplexer server filters the table types shown in Table 3-50 and regenerates them as appropriate depending on the output stream environment, number and type of inputs, and the parameters you specify in the Advanced PSI dialog box.

Table 3-50: PSI-SI-PSIP tables filtered by the multiplexer server

PSI (required)	SI (optional)	PSIP (optional)
Program allocation table	Network information table	Master guide table
Program map table	Service description table	Virtual channel table
Conditional access table	Time and date table	System time table

When the PSI-SI-PSIP input is present, all the tables in the input transport streams are filtered and the tables regenerated as described in this section. Input PID values are reassigned by the OpenMux to avoid conflicts.

This section describes how the multiplexer server filters and regenerates each PSI, SI, and PSIP table required in the output transport stream.

PSI Tables. All transport streams created using the OpenMux include the following PSI tables. These tables are extracted from the input transport streams and modified for output according to the parameters you specify on the MPEG tab and the configuration of ES and transport stream file inputs to the OpenMux. The illustration on page 3-265 shows the Advanced PSI dialog box with the MPEG panel displayed.

- Program allocation table (PAT)

All the original PAT sections of the transport stream inputs are automatically filtered when the PSI input is present. The sections are updated dynamically as inputs are added to and removed from the output.

The PAT rate and transport stream ID for the output stream are specified in the PAT group. The transport stream ID is used for the transport stream ID parameters of the PMT and SDT, and, if present, the NIT, SDT, MGT, and VCT. The PAT rate and transport stream ID can be changed after the PSI-SI-PSIP input has been added using the Edit Settings dialog box (see page 3-273).

- Program map table (PMT)

All the original PMT sections of the transport stream inputs are automatically filtered when the PSI input is present. PMTs are regenerated with the same program number if possible or with different program numbers if there are PID conflicts with other inputs. Changes to PID values are indicated in the PID Couple text box of the Filtered PID dialog box. PMT sections are added, removed, and updated as inputs are added and removed.

The PMT rate is specified in the Advanced PSI dialog box. You can change this value after the PSI-SI-PSIP input has been added using the Edit Settings dialog box (see page 3-273).

All of the original descriptors present in the input transport stream except those in the following list are rejected:

- Video stream
- Audio stream
- Language

If the ATSC option is selected, the PMT PIDs, program numbers, and elementary stream PIDs are reallocated, if needed, to be fully compliant with the ATSC environment program paradigm.

- Conditional access table (CAT)

All CAT sections, if present, are passed through to the output unless you specify which services or PIDs to remove from the output (see *Adding and removing programs from transport stream file inputs* beginning on page 3-279). The input rate is computed according to the value specified in the Advanced PSI dialog box. This value can be changed using the Edit Settings dialog box (see page 3-273).

DVB Tables. If the DVB option is selected, the DVB tab is present in the Advanced PSI dialog box. To display the DVB panel so that you can specify DVB-SI parameters, click the DVB tab. The DVB panel is displayed as shown in the following illustration.

NOTE. The NIT is a static transport stream output. To create a transport stream that meets DVB requirements, the file `openmux.nit` must be in the same directory as the multiplexer server to which you are connected. The default directory for the multiplexer server is `C:\MTS300\BIN`.

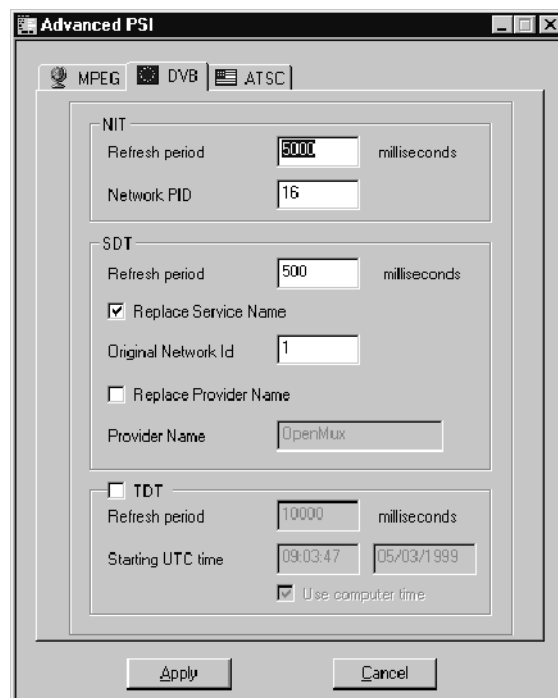

- Network information table (NIT)

You can specify the period of the NIT from the Advanced PSI dialog box. You can change this value after the PSI-SI-PSIP input has been added using the Edit Settings dialog box (see page 3-273).

- Service description table (SDT)

When the SDT check box on the DVB panel is selected, the SDT in the input is filtered, and a new SDT is generated and multiplexed into the output stream. The services and parameters of the SDT are based on the number and type of inputs and the options you specify in the SDT group. You can change these values after the PSI-SI-PSIP input has been added using the Edit Settings dialog box (see page 3-273).

The following parameters of the input SDT sections are modified as indicated:

- The transport stream ID is the same value that you specify in the PAT.
- The original network ID value is not changed in the SDT sections.
- The free CA mode is set to zero (not scrambled).
- The EIT present/following flag is set to zero (not present).
- The EIT schedule flag is set to zero (not present).
- The running status is set to four (running). Inputs that are stopped or paused after the PSI-SI-PSIP input has been added are not included in the regenerated SDT (or any other table regenerated by the OpenMux); therefore, the running status can only be set to running (4).
- All descriptors in the original SDT are rejected, except the service name descriptor. The way the service name and provider name values are handled in the output stream is described below:

If the original SDT includes a service name descriptor, and if the Replace Service Name or Replace Provider Name check boxes are not selected, the original values are used in the output stream.

If there is no service name descriptor in the original SDT, and if the Replace Service Name or Replace Provider Name check boxes are not selected, the service name descriptor is not added to the output SDT.

If there is no service name descriptor in the original SDT, and if the Replace Service Name or Replace Provider Name check boxes are selected, the provider name you specify in the SDT group and the name you specify in the Input File dialog box (see page 3-275) replace those values in the original SDT.

If there is no service name descriptor in the original SDT, and if the Replace Service Name or Replace Provider Name check boxes are selected, a service name descriptor is added to the output SDT using the provider name you specify in the SDT group and the name you specify in the Input File dialog box.

- Time and date table (TDT)

To include a TDT in the output stream, click the DVB tab in the Advanced PSI dialog box, and then ensure that the TDT check box is selected. In the TDT group, you can specify the TDT period.

By default, the OpenMux uses the computer time for the start time and date elements of the TDT. When this option is selected, the start time and date are the current time and date based on your system clock. You can specify different times by clicking the Use Computer Time check box to deselect the option, and then modifying the time and date text boxes.

After the PSI-SI-PSIP input has been added, you can change any of the TDT options using the Edit Settings dialog box (see page 3-273).

ATSC Tables. If the ATSC option is checked, the ATSC tab is present in the Advanced PSI dialog box. To display the ATSC panel so that you can specify ATSC PSIP parameters, click the ATSC tab. The ATSC panel is displayed.

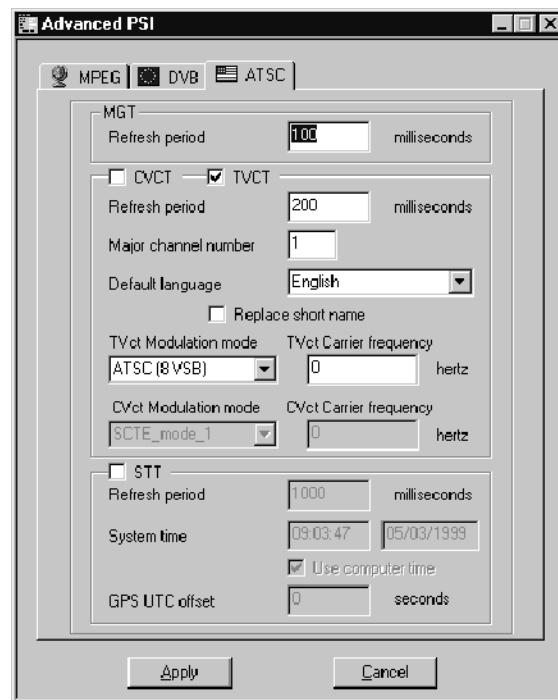

The following PSIP tables are filtered and regenerated for output according to the parameters you specify in the ATSC tab.

- Master guide table (MGT)

You can specify the MGT period in the MGT group. All other MGT values are filtered and regenerated based on the inputs. You can change this value after the PSI-SI-PSIP input has been added using the Edit Setting dialog box (see page 3-273).

- Virtual channel table (VCT)

If the CVCT or TVCT check boxes are selected, the appropriate tables are generated by the multiplexer server. All of the VCT sections and descriptors from the input transport streams are filtered, and all of the descriptors are kept for each virtual channel except the service location descriptor. The service location descriptor is regenerated by the OpenMux based on the inputs to the OpenMux to build consistent VCT sections.

You can specify the following VCT parameters only when either the CVCT or TVCT check box is selected (you can select any combination of CVCT and TVCT options):

- VCT period.
- Major channel number.
- Default language.
- Replace short name. If this check box is selected, the short name is replaced by the program number of the virtual channel. If this check box is not selected, the short name in the original VCT is used in the output.
- TVCT Modulation Mode defines the Modulation Mode field value in the terrestrial VCT. The drop-down selection box is available only when TVCT is selected.
- TVCT Carrier Frequency defines the Carrier Frequency field value in the terrestrial VCT. The drop-down selection box is available only when TVCT is selected.
- CVCT Modulation Mode defines the Modulation Mode value in the cable VCT. The drop-down selection box is available only when CVCT is selected.
- CVCT Carrier Frequency defines the Carrier Frequency field value in the cable VCT. The drop-down selection box is available only when CVCT is selected.

You can change these values after the PSI-SI-PSIP input has been added using the Edit Settings dialog box (see page 3-273).

- System time table (STT)

If the STT check box is selected, the STT is added to the output and the following fields are available for you to specify:

- STT period
- Use Computer Time. If this check box is selected, the current time of the computer is used to generate the STT. If this check box is not selected, the values you specify in the system time and date text boxes are used.

The system time and date specifies the time and date of the first occurrence of the STT table in the output transport stream.

- GPS UTC Offset. This value defines the GPS UTC Offset value (in seconds) in the STT.

Adding PSI-SI-PSIP Tables. The PSI-SI-PSIP input task is required to create a valid output transport stream using multiple inputs, and you can have only one PSI-SI-PSIP input for an output stream. To add PSI-SI-PSIP input to the OpenMux, use the following procedure:

1. If necessary, perform steps 1 through 3 of the tutorial beginning on page 3-240 (connect to a multiplexer server and set the multiplex rate).
2. Select **PSI-SI-PSIP** from the Input menu. The Advanced PSI dialog box is displayed. The following illustration shows the Advanced PSI dialog box with the DVB option selected.
3. Enter a name for the PSI-SI-PSIP input in the Name text box. This name appears in the PSI-SI-PSIP icon in the OpenMux Spy view.

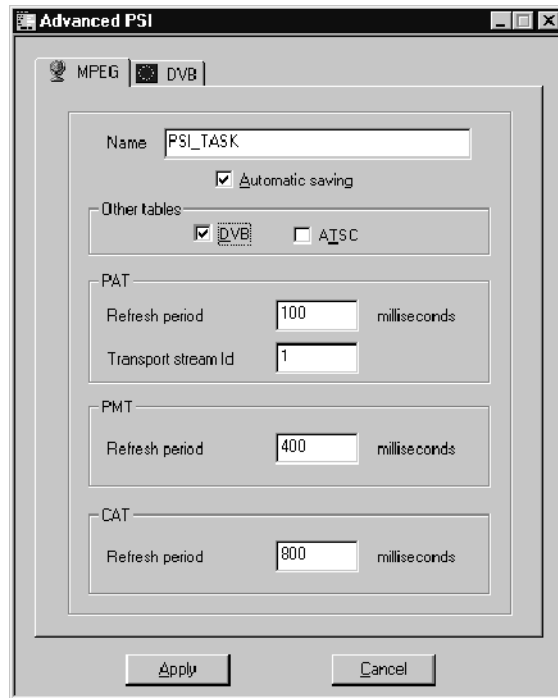

4. If you want the PSI-SI-PSIP input to be present the next time you restart the multiplexer server, ensure that the Automatic Saving option is selected. (See *Saving Multiplexer Server Configurations* beginning on page 3-260 for more information about this option.)
5. To include PSIP tables in the PSI-SI-PSIP task (to filter PSIP tables from the inputs and to modify them for output), click the ATSC option. The ATSC tab is added to the dialog box.

NOTE. For SI or PSIP tables to be filtered and modified for output, the corresponding check box must be selected, and the tab visible in the Advanced PSI dialog box.

6. Modify the parameters listed for each table type using the options available in the table type groups on each panel.
7. After you have made all of the changes you want, click **Apply** to accept your changes and close the dialog box. The PSI-SI-PSIP input icon is added to the OpenMux Spy view, and the input status is *running*. PSI-SI-PSIP input cannot be stopped, it can only be removed or running.

Changing Parameters for PSI-SI-PSIP Tables. You can modify the rate, and other parameters of output PSI, SI, and PSIP tables using the following procedure:

NOTE. To display the Edit Settings dialog box, you must manage the input, or the input must not be managed elsewhere.

1. Right-click a PSI-SI-PSIP icon in the OpenMux Spy view, and then select **Edit Settings** from the submenu. The Edit Settings dialog box is displayed.

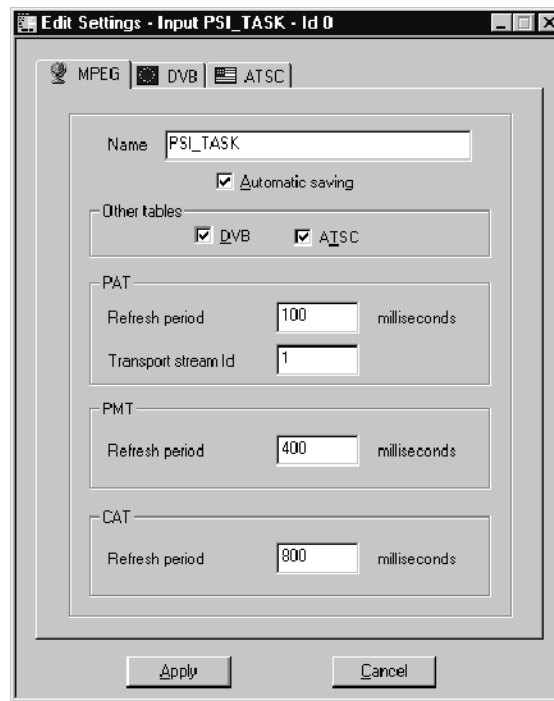

2. Click the tab for the environment that uses the table type for which you want to change the rate.
3. In the table type group, change the value in the Refresh Period text box.
4. Click **Apply** to accept your changes and close the dialog box. You can click **Cancel** at any time to close the dialog box without making any changes to the input.

The Rate value in the PSI-SI-PSIP icon changes to reflect the changes to the table rate.

Alternatively, you can use the following procedure to display the Edit Settings dialog box for inputs that you manage, or for inputs that are not managed:

1. Select **Edit Settings** from the Input menu. The dialog box that is displayed lists only those inputs that you manage or that are not managed by another OpenMux.

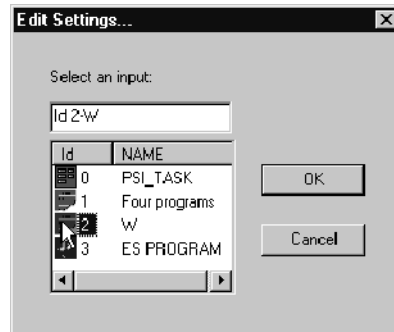

2. Select the input that you want to modify in the Select an Input selection box, and then click **OK**. The Edit Settings dialog box for the selected input is displayed (see the illustration on page 3-273).

Changing the Output Environment. You can change the output environment by removing the DVB-SI or ATSC PSIP task from the PSI-SI-PSIP input. Use the following procedure:

1. Right-click the PSI-SI-PSIP icon in the OpenMux Spy view, and then select **Edit Settings** from the submenu. The Edit Settings dialog box is displayed (see the illustration on page 3-273).
2. To change the environment, use one of the following techniques:
 - To add SI tables to the output, select the **DVB** check box on the MPEG panel. If the check box is selected, the DVB SI tables will be filtered and remultiplexed into the output stream. If the check box is not selected, SI tables are removed from the output of the OpenMux.
 - To add PSIP tables to the output, select the **ATSC** check box on the MPEG panel. If the check box is selected, the ATSC program paradigm will be used when assigning PID values to table types and program elements, and ATSC PSIP tables will be filtered and remultiplexed into the output stream. If the check box is not selected, PSIP tables are removed from the output of the OpenMux.
 - You can use both environment settings in the output, and the multiplexer server will automatically reallocate PID values to avoid conflicts.

Transport Stream File Input

The transport stream file input can be MPEG-2, DVB, or ATSC single or multiple program transport stream files. The inputs are filtered and remultiplexed according to the output environment, number and type of other OpenMux inputs, and the values you specify in the Input File dialog box.

Using the procedures described in this section, you can add, control, delete, modify, and monitor the transport stream file inputs that you manage, or that are not managed by another OpenMux. See *Managing Multiplexer Inputs* on page 3-263 for information about how to manage inputs. See *Multiplexer Limits* on page 3-234 for the limits on the number and type of transport stream file inputs to the multiplexer server.

Adding a Transport Stream File Input. After you have connected to a multiplexer server and set the multiplex rate, use the following procedure to add a transport stream file input.

1. Click **Add Input** from the Input menu, and then select **Transport File** from the submenu. The Input File dialog box is displayed .
2. Click **Browse** to select a transport stream file.
3. Select a transport stream file using the Open dialog box and click **OK** to return to the Input File dialog box. The transport stream file you selected is displayed in the Input File Name text box.

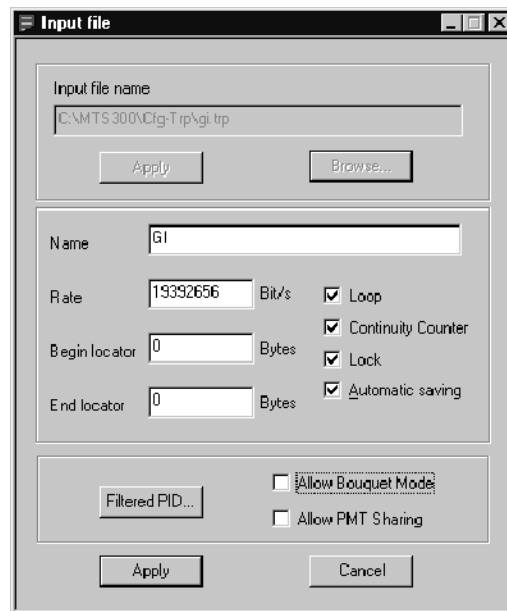

4. Make changes to the text and check boxes as explained in the following list:
 - **Name.** This parameter is used in the input icon, the Program Multiplex Allocation view, and as the value used if the Replace Service Name check box is selected in the SDT group of the DVB input panel. The default name is the name of the transport stream file.
 - **Rate.** After the transport stream file has been selected, the OpenMux analyzes the PSI information for the transport stream file and displays the transport stream file rate in this text box.
 - **Begin locator.** This parameter specifies an index in bytes from which you want the transport stream file input to start. By default the index is set to zero, the beginning of the file. If the Loop check box is selected, the file loops from this position to the End Locator.
 - **End locator.** This parameter specifies an index in bytes at which you want the transport stream file input to stop. By default the index is set to zero, the end of the file. If the Loop check box is selected, the file loops from the position indicated by the Begin Locator value to this position.
 - **Loop.** Select this check box to continuously loop the input. The loop starts and the position indicated by the Begin Locator index and restarts at the position indicated by the End Locator index.
 - **Continuity Counter.** If this check box is selected, the continuity counters are incremented for each PID of this input. If the check box is not selected, the packets are sent with the original continuity counters of this input.
 - **Lock.** If this check box is selected, the input task waits for the hard disk to fill buffers before emptying them with the remultiplexing task. This option avoids underflow.
 - **Automatic saving.** See *Saving Multiplexer Server Configurations* beginning on page 3-260 for more information about this check box.
 - **Filtered PID.** See *Removing and Adding Programs from a Transport Stream File Input* beginning on page 3-279 for more information about this dialog box. If you select this button before the input is added to the OpenMux, all the text boxes are blank. Since the input has not yet been read by the multiplexer server, and PIDs have not been compared to the output transport stream requirements and other inputs, no PID values can be represented in the dialog box.
 - **Allow Bouquet Mode.** If checked, you can combine multiple inputs into a single service.
 - **Allow PMT Sharing.** If checked you can use one PID for multiple PMTs.

5. Select **Apply** to accept your changes and close the dialog box. The Transport Stream File icon is added to the OpenMux Spy view. The input status is *stop*.
6. To start the input, double-click the input icon in the OpenMux Spy view, and then click the ► (Start) button in the Control view. The status changes to *running*, and the PSI-SI-PSIP rate changes to reflect the change to the output stream.

Controlling a Transport Stream File Input. After you have added a transport stream file input to the OpenMux, the input status is *stop*. The input, and the associated PSI-SI-PSIP data, is added to the output stream only when the input is running. Use the following procedure to control the status of an input.

1. Double-click the icon for the input in the OpenMux Spy view. The Control view for the input is displayed.

NOTE. In order to change the management of an input, the Control view for that input must be closed.

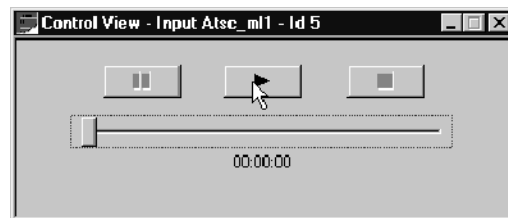

Use one of the following techniques to change the status of an input:

- To start an input, click the ► (Start) button. The slider and the position indicator just below it, change to reflect the change in status. The associated PSI-SI-PSIP data, is added to the output stream.
 - To pause an input, click the ■■ (Pause) button. The associated PSI-SI-PSIP data is removed from the output stream. When you restart the input, the input starts at the point in the file at which it was paused.
 - To stop an input, click the ■ (Stop) button. The associated PSI-SI-PSIP data is removed from the output stream. When you restart the input, the input starts at the beginning.
2. To close the Control view for an input, click the **Close** title bar button.

Deleting a Transport Stream File Input. You can delete only those inputs that you manage, or that are not managed by another OpenMux. After an input is added to the OpenMux, you can delete it using the procedure described in this section. (This procedure can also be used for deleting elementary stream program inputs.)

1. Right-click the icon for the input you want to delete, and then select **Delete** from the submenu.
2. In the Delete an Input dialog box that is displayed, make one of the following choices:
 - Select **No** to close the dialog box without making any changes to the OpenMux.
 - Select **Yes** to display the Delete Input Task dialog box. In this dialog box you specify whether you want the input task to finish, or whether you want the input deleted immediately. Select an option, and then close the dialog box.

If you do not manage the input you selected, the dialog box displays the following message. Click OK to dismiss the dialog box.



You can delete all inputs at once by selecting Delete All Inputs from the Input menu.

Removing and Adding Programs from a Transport Stream File Input. Programs, in this case, refer to the PSI-SI-PSIP sections specific to a service or virtual channel and the elementary stream files associated with that service or virtual channel. After an input is added to the OpenMux, you can use this procedure to remove programs from, or add programs to the output stream. (You can use this procedure for removing an audio stream file from a program input.)

1. In the OpenMux Spy view, right-click the input icon for the multiple program transport stream from which you want to remove one or more programs.
2. Select **Hierarchic View** from the submenu. The Hierarchic view for the selected input is displayed.

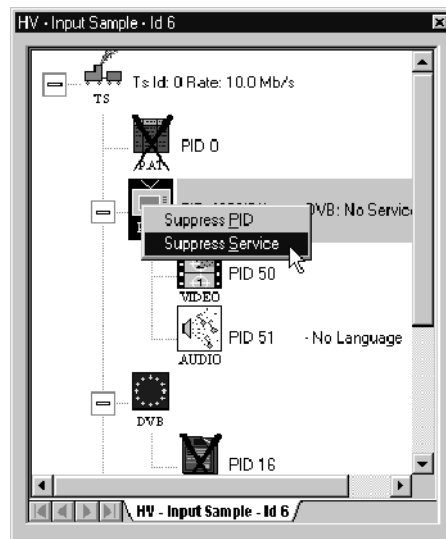

NOTE. Programs are represent in the Hierarchic view by a PMT icon and the elementary stream icons subordinate to it. However, when you remove a program from the output stream, you also remove all PSI-SI-PSIP data related to the program in the output.

3. Right-click the PMT icon for the program you want to remove, and then select **Suppress Service** from the submenu.

4. The Hierarchic view is updated, showing that the program elements (the PMT and the elementary stream icons) have been removed. The PSI-SI-PSIP rate changes to reflect the new input parameters, and the program does not appear in the output stream.

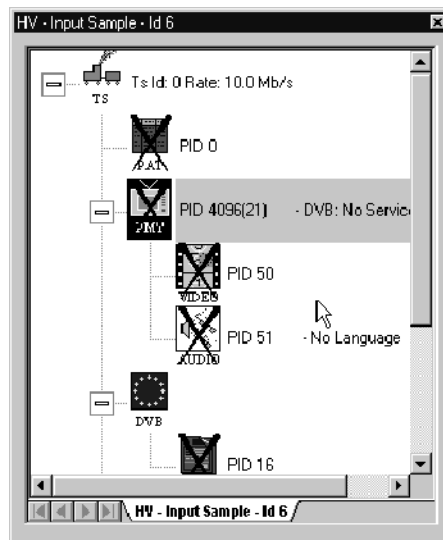

5. You can add the service (program) again, by repeating step 3 and selecting **Restore Service** from the submenu.

NOTE. You can also remove specific video, audio, data, or conditional access elements and change PIDs using the procedure described in this section.

Using the Filtered PID Dialog Box to Exclude Packets in Transport Stream Inputs.

You can use the procedure in this section to specify PID values for specific packets that you want to exclude from the output stream. You can use the MTS300 System Analyzer to determine the PIDs for the packets you want to exclude from the output. Alternatively, you can use the Hierarchic view for the input; however, this view does not list PMT PIDS or program numbers.

1. Do one of the following to display the Edit Settings dialog box:
 - Right-click the icon of an input for which you want to exclude specific PIDs, and then select **Edit Settings** from the submenu. The Edit Settings dialog box for the input is displayed.
 - Select **Edit Settings** from the Input menu, and then double-click the input task number in the dialog box as shown in the following illustration. The tasks that are displayed in the selection box are tasks that you manage or that are not managed by another OpenMux.

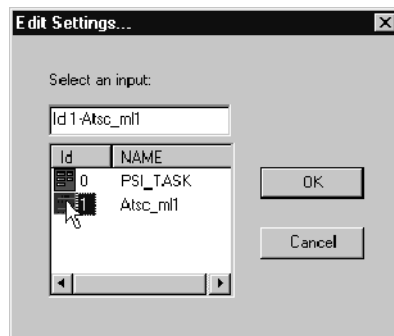

2. Click the **Filtered PID** button (toward the bottom of the dialog box), and the Filtered PID dialog box is displayed.

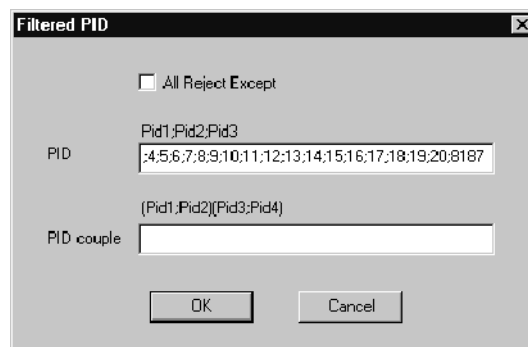

The values in the PID text box are PID values that the multiplexer excludes from the output stream by default. The following list describes how to use the Filtered PID dialog box to exclude or change PIDs in the output stream.

- Select the **All Reject Except** check box to exclude the PIDs not listed in the PID text box. When this check box selected, those PIDs appearing in the PID text box are the only PIDs present in the output stream.
 - Clear the **All Reject Except** check box to exclude all PIDs listed in the PID text box. When this check box is not selected, PIDs appearing in the PID text box will not be present in the output stream.
 - Change PID values using the PID Couple text box. Parentheses group PID couples: the first number is the input PID value, and the second number is the output PID value.
3. Ensure that the **All Reject Except** check box is not selected, and then enter the PID for the packets you want to exclude in the PID text box. (It is okay to delete the PIDs in the text box, they will be replaced when you close the dialog box.) PIDs can be entered in any order.
 4. After you have made the all the PID modifications you need to, click **OK** to accept your changes and close the dialog box. Click **Cancel** at any time to close the dialog box without making any changes.
 5. Click **Apply** in the Edit Settings dialog box to accept the changes. Click **Cancel** to close the dialog box without making any changes to the output stream.

The PIDs you specified no longer appear, or are changed, in the output stream.

Monitoring Inputs. You can use the views described in *Hierarchical Views* beginning on page 3-256 to monitor transport stream file and elementary stream file program inputs and to monitor output streams. You can use the views described in *Multiplex Allocation Views* beginning on page 3-258 to monitor output streams. You can use the Information message window shown below to monitor all three input types: PSI-SI-PSIP, transport stream file, and elementary stream file program inputs. To display the Information window for an input, right-click the input icon, and then click **Information** from the submenu.

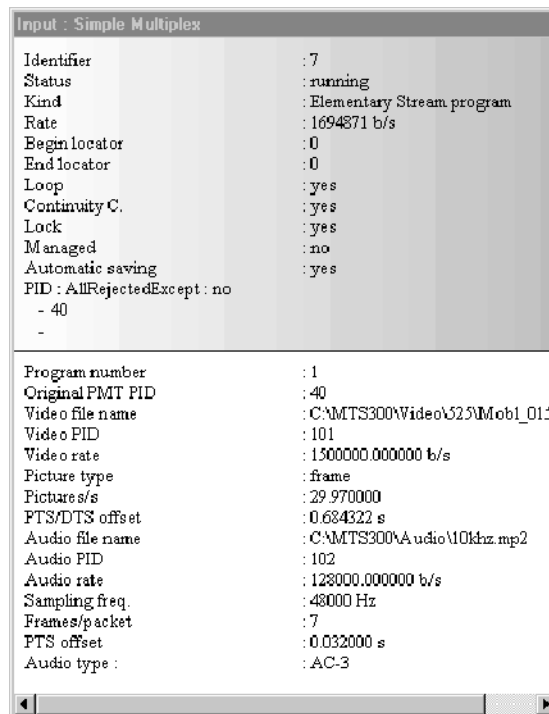

This message window displays the status of the input, where in the file the OpenMux is reading, and other information about the input.

Elementary Stream Program Input

In addition to remultiplexing transport stream files, you can include video and audio elementary stream files as inputs to the OpenMux. Since this type of input does not include associated PSI, SI, or PSIP table files, the multiplexer server creates them dynamically or updates the tables already being created to account for the elementary stream file input.

The following lists describe the constraints on the elementary stream program input and the constraints on the video and audio file components:

Elementary Stream File Program Constraints.

- No more than six elementary stream program inputs for an output
- The PCRs for the program (service) are carried by the video packets
- One video elementary stream file is required for each input; audio elementary stream files are optional

Video Elementary Stream File Constraints.

- MPEG 2, Main Profile@Main Level video elementary stream files only

Audio Elementary Stream File Constraints.

- MPEG-2, Layer II audio elementary stream files only
- AC-3 audio elementary streams must have a constant bit ratio

Table 3-51 shows the valid configurations of bit rate and sampling frequency:

Table 3-51: Bit rate and sampling frequency for the audio component

Bit rate (kbps)	Sampling frequency		
	32 kHz	44.1 kHz	48 kHz
32	✓	✓	✓
40	✓	✓	✓
48	✓	✓	✓
56	✓	✓	✓
64	✓	✓	✓
80	✓	✓	✓
96	✓	✓	✓
112	✓	✓	✓
160	✓	✓	✓

Table 3-51: Bit rate and sampling frequency for the audio component (Cont.)

192	✓	✓	✓
224	✓	✓	✓
256	✓	✓	✓
320	✓	✓	✓
384	✓	✓	✓
448	✓	✓	✓
512	✓	✓	✓
576	✓	✓	✓
640	✓	✓	✓

Many of the procedures described in *Transport Stream File Input*, beginning on page 3-275, can be used to control, modify, monitor, and delete this type of input. Unlike transport stream file input, once elementary stream program input is added to the OpenMux, the program parameters cannot be changed through the Edit Settings dialog box; however, PID values can be changed in the Hierarchic view, and you can view ES Program input settings.

1. Click **Add Input** from the Input menu, and then select **ES Program** from the submenu. The ES Program dialog box is displayed.
2. Enter a name for the input task in the Input Name text box.
3. Enable the following options if appropriate:
 - Allow Bouquet Mode allows you to combine multiple inputs into a single service.
 - Allow PMT Sharing allows you to use one PID for multiple PMTs.
4. Click **Browse** in the MPEG 2 VIDEO Component group, and then select a video elementary stream file using the Open dialog box.
5. If the Add Audio Component check box is selected, repeat step 4 for the audio elementary stream.
6. Change the values of the PSI and elementary stream parameters using the check and text boxes if necessary.
7. Click **OK** to accept your changes and add an elementary stream program input to the OpenMux. The input icon is added to the OpenMux view. Click **Cancel** to close the dialog box without adding the input.

Video Component Error Messages.

It is not a video data file. The name of the video data file does not correspond to a video file or the video file does not exist. Video files with PES packets or Transport Packets are not accepted.

The PID of the video must have a value between 16 and 8190. The current value is set by default.

The video file does not respect the constraint : “constant bit rate”. The real-time multiplexer deals only with constant bit rate stream. If it is not respected, the video file name is not saved.

NOTE. *During the analysis of the video file, the bit rate value is read in the first sequence header and the size of Video Buffer Verifier in bits is read in the first sequence header.*

If the bit rate value is set to 0x3FFFF and size of the Video Buffer Verifier is set to 0xFFFF, the video file is not accepted. Otherwise the video will be treated as though it has a constant bit rate.

The video file does not respect the constraint : “main level”. The real-time multiplexer only processes elementary streams with main levels. If it is not respected, the video file name is not saved.

NOTE. *The value of level is read in the first sequence extension after the first sequence header during the analysis of the video file.*

The video file does not respect the constraint : “main profile”. The real-time multiplexer only processes elementary streams with main profiles. If it is not respected, the video file name is not saved.

NOTE. *When a video file name has been specified, the video file is analyzed. The read value of profile level, is in the first sequence extension after the first sequence head. This message indicates that the value does not correspond to main profile.*

The video file does not respect the constraint: “MPEG-2 mode”. The real-time multiplexer only processes the MPEG-2 standard stream. If it is not respected, the video file name is not saved.

NOTE. *The standard is recognized as MPEG-1 if there is no sequence extension, otherwise, it is considered to be MPEG-2.*

You must give the name of the video and audio files. At the creation of the input, when clicking on the OK button or pressing the RETURN key (after filling a field), the presence of file names is checked. If there is no video name and no audio name (and audio is present), the input cannot be created.

You must give the name of the video file. At the creation of the input, when clicking on the OK button or pressing the RETURN key (after filling a field), the presence of the video file name is checked. If there is no video name, the input cannot be created.

Audio Component Error Messages.

Audio mode does not correspond to expected mode according to the bit rate and sampling frequency values. According to the bit rate and sampling frequency values, the OpenMux expects to have a given audio mode. If it is not respected, the audio file name is not saved.

NOTE. *Bitrate and sampling frequency are both read in the first audio header.*

It is not an audio data file. The name of the audio data file does not correspond to an audio file or the audio file does not exist. Audio files with PES packets or Transport Packets are not accepted.

Audio files with 22.05 kHz sampling frequency are not treated. The real-time multiplexer does not process streams with 22.05 kHz sampling frequency. If it is not respected, the audio file name is not saved.

NOTE. *The value of sampling frequency index is read in the first audio header.*

The audio file does not respect the constraint: “layer 2”. The real-time multiplexer does not process streams with a layer other than layer 2. If it is not respected, the audio file name is not saved.

NOTE. *The value of the layer index is read in the first audio header. Then a table given by the standard provides the layer value.*

The PID of the audio must have a value between 21 and 8190. The current value is set by default.

The rate of the audio file is null! In such a case, The real-time multiplexer cannot accept the rate because it is used to compute other information such as frame length. If the rate is null, the audio file name is not saved.

NOTE. *Bit rate is defined from the read value of the mode index (MPEG-1 or MPEG-2), of the bit rate index, of the layer index and the corresponding table in MPEG standard. Rate value can be null because the read layer index is incorrect or the value in table is null.*

The sampling frequency of the audio file is null! In such a case, the OpenMux cannot accept the rate because it is used to compute other information such as frame length. If sampling frequency is null, the audio file name is not saved.

NOTE. *Sampling frequency is defined from the read value of the mode index (MPEG-1 or MPEG-2), of the sampling frequency index and the corresponding table in standard.*

You must give the name of the audio file. At the creation of the input, when the audio component is specified, when clicking on the OK button or pressing the RETURN key (after filling a field), the presence of audio file name is checked. If there is no audio file name, the input cannot be created.

You must give the name of the video and audio files. At the creation of the input, when clicking on the OK button or pressing the RETURN key (after filling a field), the presence of file names is checked. If there is no video name and no audio name (and audio is present), the input cannot be created.

PID Error Messages.

The PID of the PMT must have a value between 21 and 8190. The current value is set by default. The program number must have a value between 0 and 65535. The current value is set by default.

The PID is already used for the PMT or for the audio component.

The PID is already used for the PMT or for the video component.

The PID is already used for the video or the audio component.

Multiplexer Outputs

The output task allows you to generate a transport stream with the inputs and parameters you specify using the OpenMux. Once an output is added to the OpenMux Spy view, you can remove it, change the multiplex rate, or you can monitor the output using the views described in *Multiplexer Windows, Views, and Interface Elements*, beginning on page 3-246. Use the procedures described in this section to add and remove an output and to change the multiplex rate.

Adding an Output

To add an output to the OpenMux configuration, select **Start Multiplex** from the Multiplex menu (or click the ► button on the toolbar).

Removing an Output

To remove an output task, click the ■ button on the toolbar.

Changing the Multiplex Rate

The sum of input rates may be different than the output rate. In fact, because null packets in the inputs are discarded by the OpenMux, the ideal output rate can be lower than the sum of the input rates. To change the output rate, use the following procedure:

1. Click the ■ (Stop Multiplex) button on the toolbar.
2. Select **Multiplex Rate** from the Multiplex menu and change the rate in the dialog box.
3. Click the ► (Start Multiplex) button on the toolbar to restart the multiplex.

Appendix A: What to Do if an Application Locks Up

In the event an application locks up or freezes, perform the following steps to close the application.

1. Press **CTRL+ALT+DEL** to open the Windows NT Security dialog box.
2. Click **Task Manager** to open the Windows NT Task Manager.
3. Click the **Applications** tab, and then highlight the locked-up application (usually the status of the application will indicate *Not responding*).
4. Click **End Task**.
5. In some circumstances, a window opens prompting you to wait, end the task, or cancel your “end task” instruction. Follow the window instructions; if you click End Task, the application should close immediately.
6. If the above procedure fails to close the application, press **CTRL+ALT+DEL** again to return to the Windows NT Security dialog box.
7. Click **Shut Down**. This opens the Shutdown Computer dialog box.
8. Select **Shutdown and Restart**; then click **OK**.



CAUTION. *To avoid data loss, do not power off the computer without first exiting Windows NT. Only use the manual reset if the computer does not respond.*

If the above procedures do not close the application or restart the computer, manually power off the computer, and then proceed with a normal power on. To ensure that all parameters are reset, perform a complete power cycle following an application lock up.

Appendix B: Software Repair

This appendix tells you how to uninstall and reload the test system software if the installed copy is corrupted. See the *MTS300 MPEG Test System Hardware and Software Installation Technical Reference* (Tektronix part number, 071-0667-xx) for information about rebuilding the operating system for the MTS300 test system.

Reinstalling the MTS300 Software

Use the procedures below to reinstall your applications accidentally deleted or corrupt. Software is supplied on CD ROM.

NOTE. *The following instructions are for reinstalling MPEG Test System software on a machine running Windows NT Workstation 4.0 only; procedures for upgrading your software could be different. If you are installing a software upgrade, follow the instructions provided with the upgrade kit.*

Reinstalling the software involves three procedures:

- Uninstalling the current software
- Installing the software
- Entering passwords for licensed applications

NOTE. *You may need to reinstall the Java run-time environment before you re-install the MTS300 software (if you are installing either the TMCC Expert or Configuration clients, or the TMCC Deferred-Time Analyzer). The correct version of the Java run-time environment is located on the Application CD in the jre directory. To install the correct version of the run-time environment, run the executable file in this directory.*

Uninstalling Software

Remove the existing software using the unInstallShield application.

1. Restart Windows NT and log on as the administrator (Username = administrator; password = MPEG2). This is the default auto-logon username and password for MTS300 Test Systems.
2. Quit any applications that automatically started at login.
3. Double-click the **Uninstall MTS3...** icon in the Tektronix MPEG Test System program group window.
4. When the dialog box asks you to confirm the file deletion, click **Yes**.
5. When uninstall is complete, Click **OK** to close the Remove Programs From Your Computer window.
6. If prompted, click **OK** to restart your computer.

Installing Software

1. If you are not already logged on, log onto your NT workstation as Administrator (this is the default user name, so unless you have changed this parameter, you will be able to install software using the default user name and password: Administrator and MPEG2 respectively).
2. Right-click the **My Computer** icon on your Windows NT desktop, and then select **Explore** from the submenu. In the Exploring window, select the icon that represents the disk drive onto which you will install the software (usually drive C:).
3. Check the status bar at the bottom of the Exploring window to verify that the target disk has at least 140 MB of free space. You cannot install the software on a disk that has less than 140 MB of free space.

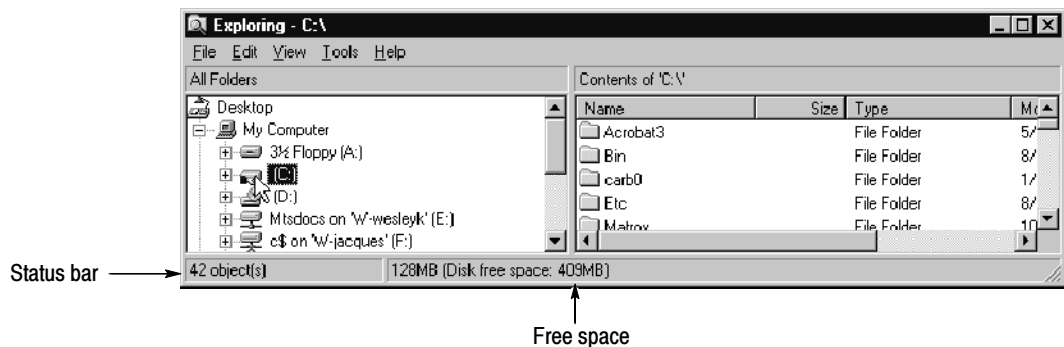

4. Place the MPEG Test System Version 6.0 Installation Software CD ROM into the CD ROM drive.
5. Click the Windows NT Start button, and then select **Run**.

6. Enter `d:\Setup.exe` in the resulting Run window as depicted in the following illustration (in this example, *d* is the drive letter for the CD ROM drive; use the drive letter that is correct for your computer), and then click **OK**.



7. In a few seconds, the Tektronix MTS300 Series window appears on the computer screen.
8. Read the Copyright and Setup text and then click **Next** to proceed to the Choose Destination Directory window.

NOTE. *It is strongly recommended that you use the default destination folder.*

9. The default destination folder is `C:\Mts300`. Click **Next** to accept the default folder.
10. The Setup Type window opens.

- If you are installing the software on a machine that has no MPEG Test System hardware, select **MTS300 Software Only**.

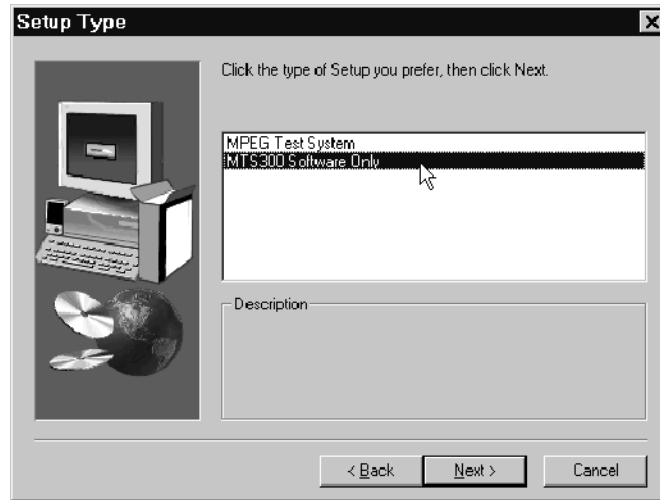

- If you are installing software onto an MPEG Test System, select **MPEG Test System** and continue with the procedure as described in the *MTS300 MPEG Test System Hardware and Software Installation Technical Reference* that accompanied the test system.
11. Click **Next** in the Select Program Folder window to accept the default folder name (Tektronix MPEG Test System) and continue.
 12. Review the Destination Directory, Selection, and Start Menu Folder selections in the Selection Summary window. If the selections are incorrect, click **Back** and change the information as needed. Once the information is correct, click **Next** to proceed with installation.

The setup program begins installing the software and related sample files. The activity and progress gauges appear at first to show that installation is progressing.

Installation proceeds without your input (and sometimes with no apparent activity) for approximately two minutes, depending on your computer platform.

During a normal setup, two empty program group windows are displayed after the program files have been copied to your disk drive. Shortly after these windows appear, a message reminds you to verify that the Dongle (software key) is installed.

13. Ensure that the software key is installed on the parallel printer port as described in *Software Key* on page 1-10, and then click **OK**.
14. The Setup Complete window opens; click **Finish** to continue.
15. A Notepad window opens to display the Readme file. Read this file for important information, and then exit Notepad.
16. Another Setup Complete window opens. Accept the *Yes, I want to restart my computer now* option, remove the MPEG Test System disc from the CD ROM drive, and click **Finish** to complete setup and reboot the system.

NOTE. *You need to restart your computer before you enter the license password in the next procedure.*

17. If prompted, log on as any user.
18. If not already displayed, open the Tektronix MPEG Test System program group window by double-clicking the folder icon on the desktop.



The program group window resembles the following illustration.

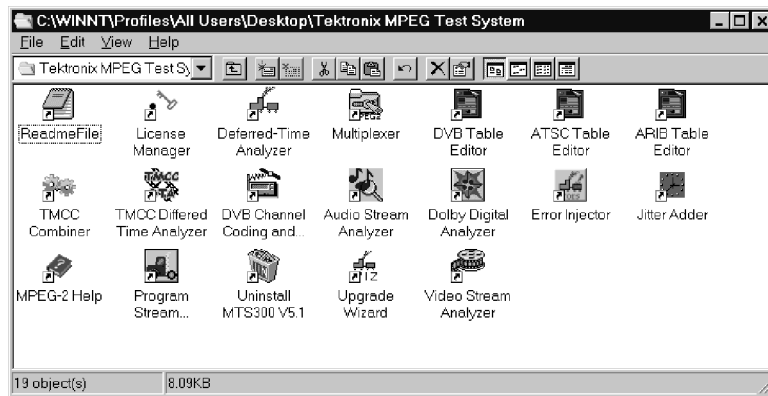

Entering the General License Password



Perform the remaining steps to enter the general password that corresponds to the attached software key. Doing so enables the applications that are included with your MTS300 MPEG Test System product.

1. Double-click the **License Manager** icon in the Tektronix MPEG Test System program group window to start the Tektronix Software Protection application.

The Tektronix Software Protection window appears.



2. Consult the password document supplied with your software and identify the general password.
3. Enter the three 6-character hexadecimal numbers of the password in the corresponding Tektronix Software Protection window entry fields (lowercase characters are acceptable).
4. Click **OK**. A License message window appears.
5. If the password is correct, click **OK** to acknowledge the message. If you made an error entering the password, click **OK** and return to step 2.

When you enter the correct password, software installation is complete. You will need to restart the computer before you can start any of the stream creation applications.

Glossary

NOTE. Additional information about MPEG-2 is available through the MPEG-2 Help application, part of the MPEG Test System software.

AC-3

Audio coding scheme developed by Dolby Laboratories, Inc. and adopted by ATSC.

ARIB (Association of Radio Industries and Business)

ARIB is a body of broadcasters, manufacturers, and communication carriers who are responsible for preparing standards on radio spectrum use in Japan.

ATSC (Advanced Television Systems Committee)

The Advanced Television Systems Committee was formed to establish voluntary technical standards for advanced television systems, including digital high definition television (HDTV).

BAT (Bouquet Association Table)

The BAT provides information regarding bouquets. DVB only.

BIT (Broadcaster Information Table)

ARIB only. The BIT provides broadcaster name and ID and descriptions of the services encoded in the transport stream for each broadcaster.

Bouquet

A group of transport streams in which programs are identified by the network ID and PID pair of values.

CAT (Conditional Access Table)

The CAT provides the association between one or more CA systems, their EMM (Entitlement Management Message) streams, and any special parameters associated with them. See ECM and EMM.

CVCT

VCT for cable broadcast environments.

DCT (Download Control Table)

ARIB only. This table provides a list of available downloads encoded in the transport stream.

DIT (Discontinuity Information Table)

DVB table. This table is included only in partial streams; the DIT is never broadcast.

DLT (Download Table)

ARIB only. This table is used when downloading software to set top boxes.

DTS (Decode Time Stamp)

Time when the packet should be decoded.

DVB (Digital Video Broadcast)

A project group of the European Broadcasting Union (EBU).

DVB IRD (Digital Video Broadcasting Integrated Receiver Decoder)

A receiving decoder that can automatically configure itself using the MPEG-2 Program Specific Information (PSI).

DVB-SI (Digital Video Broadcast Service Information)

The DVB-SI adds the information that enables DVB IRDs to automatically tune to particular services and allows services to be grouped into categories with relevant schedule information. DVB-SI information is transmitted in several tables, including: NIT, SDT, BAT, and EIT.

ECM (Entitlement Control Message)

Conditional access information specifying control words or other stream-specific scrambling parameters.

EIT (Event Information Table)

DVB. The EIT contains data concerning events (a grouping of elementary broadcast data streams with a defined start and end time belonging to a common service) and programs (a concatenation of one or more events under the control of a broadcaster, such as event name, start time, duration, etc.).

ATSC. The EIT contains information for the events defined on defined on the virtual channels of the transport stream. An event is, in most cases, a typical TV program, however its definition may be extended to include particular data broadcasting sessions and other information segments.

EMM (Entitlement Management Message)

Conditional access information specifying authorization levels or services of specific decoders.

ETM (Extended Text Message)

An ETM is a multiple string data structure. Thus, it may represent a description of an event or channel in several different languages (each string corresponding to one language).

ETT (Extended Text Table)

The Extended Text Table (ETT) contains Extended Text Message (ETM)

streams, which are optional and are used to provide detailed descriptions of virtual channels (channel ETM) and events (event ETM).

EPG (Electronic Program Guide)

The EPG gives the content of the current program.

Frame

An ISDB-S/ARIB structure comprised of 48 slots. *See Slot* and *Super frame*.

ISDB-S (Integrated Service Digital Broadcast Satellite)

Standard adopted by ARIB describing the TMCC information used in satellite broadcast environments.

Mega-frame

A mega-frame is a valid MPEG-2 structure used in DVB terrestrial environments in which the transport packets are organized into groups called mega-frames. Each mega-frame consists of n packets, where n is an integer number that depends on the number of Reed-Solomon (RS)-packets per super-frame in the DVB-T mode being used for DVB-T emission of the MPEG-2 transport stream. Each mega-frame includes exactly one MIP.

MGT (Master Guide Table)

The MGT lists version numbers, length in bytes, and PIDs for all of the PSIP tables with the exception of the STT which works independently from the other tables. ATSC only.

MIP (Mega-frame Initialization Packet)

The MIP is an MPEG-2 compliant TS packet made up of a 4-byte header and a 184-byte data field. The MIP is used to indicate the start of the following mega-frame and is used for synchronization of the Single Frequency Networks (SFN) as well as for the optional control of other important parameters in an SFN.

M_TMCC

An ISDB-S compliant multiplex with multiple transport streams. *See TMCC*.

NIT (Network Information Table)

The NIT conveys information relating to the physical organization of the multiplex, transport streams carried via a given network, and the characteristics of the network itself. Transport streams are identified by the combination of an original network ID and a transport stream ID in the NIT.

NVOD (Near Video on Demand)

A group of services that carry the same event sequence at start times that are offset from one another.

PAT (Program Association Table)

For each program (service) in the multiplex, the PAT specifies the PID values of the corresponding PMT. It also specifies the PID of the NIT.

PCR (Program Clock Reference)

The program reference clock or “clock on the wall” time when the video is multiplexed.

PES (Packetized Elementary Stream)

A structure defined in the MPEG-2 standard used to carry elementary stream data.

PID (Packet Identifier)

One of the parameters defined by the MPEG-2 standards. A unique integer value, PIDs are used to associate elementary streams of a program in a single or multi-program transport stream.

PMT (Program Map Table)

The PMT identifies and indicates the locations of the streams that make up each service and the location of the Program Clock Reference (PCR) fields for a service. This table is transmitted in sections.

Program paradigm

In ATSC environments, the program paradigm specifies the method that shall be used for systematically allocating PID values of transport packets.

PSI (Program Specific Information)

The PSI contains all the tables that define the MPEG-2 transport stream. It consists of the PAT, PMT, CAT, and NIT tables. (NIT is also used for DVB-SI.)

PSIP (Program and System Information Protocol)

SI and program guide tables contained within packets carried in the Transport Stream multiplex for digital multiplex bit streams constructed in accordance with ISO/IEC 13818-1 (MPEG-2 Systems).

PTS (Presentation Time Stamp)

When the packet should arrive and its destination.

RRT (Rating Region Table)

The RRT carries rating information for multiple geographical regions. ATSC only.

SDT (Service Description Table)

The SDT contains data describing the services in the system. Examples include: names of services, the service provider, etc.

SDTT (Software Download Trigger Table)

ARIB only. This structure is used to define the service, group, and schedule for downloadable items encoded in the transport stream.

SFN (Single Frequency Network)

SFN is an extension of the DVB system in which all transmitted signals are identical; therefore, the MPEG-2 TS inputs to the various DVB-T modulators have to be bit identical.

SI (Service Information)

SI provides information on services and events carried by different multiplexes, and even other networks. SI is structured as several tables (BAT, EIT, NIT, RST, SDT, and TSDT).

SIT (Selection Information Table)

DVB-SI table. This table is used only with partial streams; the SIT is never broadcast.

Slot

An ISDB-S/ARIB structure corresponding to one, 204-byte error coded packet. *See Frame and Super frame.*

S_TMCC

An ISDB-S/ARIB compliant multiplex with only one transport stream. *See TMCC.*

STT (System Time Table)

The STT provides the current date and time of day information. ATSC only.

Super frame

An ISDB-S/ARIB structure comprised of eight frames. *See Frame and Slot.*

TMCC (Transmission and Multiplexing Configuration and Control)

Information encoded in the first eight bytes of the 16-byte Reed-Solomon area of 204-byte packet transport streams. TMCC information includes modulation modes, slot assignments, and alarms.

TVCT

VCT for terrestrial broadcast environments.

VCT (Virtual Channel Table)

The VCT contains a list of attributes for virtual channels carried in the transport stream. ATSC only.

Index

A

- AC-3, definition, Glossary-1
- AC-3 audio descriptor, 3-185
- Actual rate, multiplexer, 3-8
- Add
 - button, 3-35
 - multiplexer
 - ARIB icon to hierarchy, 3-25
 - button, 3-6
 - EIT instances, 3-71
 - elementary stream files to the configuration file, 2-10
 - elementary streams, 3-46
 - ETT instances, 3-76
 - items to the hierarchic view, 3-34
 - MIP icon to hierarchy, 3-23
 - multiple EIT instances, 3-73
 - programs, 3-44
 - PSIP icon to hierarchy, 3-26
 - PSIP tables, 3-62
 - SI icon, 3-22
 - SI tables, 3-52
 - TDT, 3-54
 - TSDT, 3-35
 - use of with multiplexer icons, 3-35
 - using the Add button, 3-35
 - video splice, 3-52
 - real-time multiplexer
 - a program to a transport stream input, 3-279
 - elementary stream program input, 3-285
 - output, 3-289
 - PSI-SI-PSIP tables, 3-271
 - SI and PSIP tables to the output, 3-274
 - transport stream files, 3-275
 - table editors, 2-31
 - descriptors, 3-122
 - stream, service, or event, 3-120
 - table items, 3-117
- Address, Tektronix, xvii
- Advanced Television Systems Committee. *See* ATSC
- Algorithms for scrambling streams, CCEIT and DVB, 3-90
- Analysis
 - coherence, 3-126
 - consistency, 3-126
 - interpreting error messages, 3-130
 - tables, 3-126
 - types of, 3-130
 - using the message window, 3-128
- Analysis menu, table editors, 3-101
- Application, locked, A-1
- Application window
 - multiplexer, 2-8, 3-5
 - real-time multiplexer, 3-246
 - table editors, 3-95
- Apply Following Configuration at OpenMux Starting, real-time multiplexer, 3-262
- ARIB
 - changing environment options, 3-25
 - definition, Glossary-1
 - edit period parameters, 3-40
 - multiplexer, adding the environment, 3-25
 - remove multiplexer environment option, 3-25
- ASCII, text in table editors, 3-121
- Associating ETT to events, PSIP table editor, 3-136, 3-138
- Associating VCT, EIT, and ETT, 3-136
- ATSC
 - changing environment options, 3-26
 - definition, Glossary-1
 - program paradigm, multiplexer, 2-25
 - real-time multiplexer, 3-269
- ATSC DVB multiplexer, description, 1-1
- ATSC Table Editor, description, 1-2
- Audio, file types, 3-50
 - displayed in the Audio Stream dialog box, 3-49
- Audio elementary stream
 - adding to a multiplexer configuration file, 2-15
 - adding to the multiplex, 3-49
 - initial delay parameter, 3-50
 - multiplexer, icon, 3-14
- Audio Stream Analyzer, description, 1-8
- audio stream descriptor, 3-163
- Audio Stream dialog box, 2-15
- Automatically Save the OpenMux Configuration, real-time multiplexer, 3-262

B

- B Sync Byte
 - add only module, 3-202
 - removal, 3-207
- Bandwidth, MIP parameter, 3-58
- BAT
 - bouquet association table, 3-21
 - definition, Glossary-1
 - multiplexer, icon, 3-12
 - table editors, parameters, 3-145
 - transport streams in, 3-154
- BIT, definition, Glossary-1
- Bit Stream CD ROM, 1-2
- blue dot, on toolbar buttons, table editors, 3-102
- bouquet name descriptor, 3-169
- Buttons
 - Jitter Adder, 3-198
 - real-time multiplexer commands, 3-250
 - table editors, 3-102
 - TMCC Combiner, 3-218
- Bytes, Number of bytes in the pattern, 3-208

C

- CA (conditional access) identifier descriptor, 3-170
- Cable ATSC, multiplexer environment option, 3-25, 3-26
- cable delivery system descriptor, 3-171
- Calculate packet jitter, 3-196
 - command button, 3-198
- caption service descriptor, 3-186
- CAT
 - definition, Glossary-1
 - multiplexer
 - adding, 3-90
 - icon, 3-11
 - period, 3-38
 - real-time multiplexer, 3-267
 - table editors, parameters, 3-145
- CCEITT, scrambling algorithm, 3-90
- Chain command
 - coding and decoding, 3-202
 - decoding menu, 3-207

Changing

- ARIB environment options, 3-25
- ATSC environment options, 3-26
- DVB environment options, 3-21
- DVB-T Mega-frame environment options, 3-23
- Dynamic SI environment options, 3-27
- multiplexer
 - ARIB parameters, 3-40
 - PAT parameters, 3-41
 - PSI parameters, 3-38
 - PSIP parameters, 3-40
 - PSIP periods, 3-64
 - SI parameters, 3-39
- multiplexer environment options, 3-21
- passwords, 1-15
- PSI period in multiplexer, 2-28
- real-time multiplexer
 - multiplex rate, 3-289
 - output environment, 3-274
 - PSI-SI-PSIP tables, 3-273

Choosing

- audio elementary streams in multiplexer, 3-49
- data stream in multiplexer, 3-51
- video streams in multiplexer, 3-47

Clock jitter, 3-191

Close All, PSIP table files, 3-110

Close table files, 3-110

Code rate, MIP parameter, 3-59

Coded block size, Reed-Solomon, 3-204

Coding

- convolutional interleaving, 3-212
- DVB, 3-199
- energy dispersal, 3-211
- menu, 3-202
- Reed-Solomon, 3-212
- Satellite broadcasting, 1-3
- Viterbi, 3-213

Coding Flow, 3-199

Coding types, 3-211

Coherence/Consistency analyses, table editors, 3-126

Collapse/Expand hierarchy

- global view, 3-135
- multiplexer, 3-15
- table editors, 3-96

Colors, multiplex rate gauge, 3-9
 Command buttons, table editor, 3-102
 component descriptor, 3-171
 component name descriptor, 3-186
 Composition Motif, pattern, 3-209
 Conditional access, 3-89
 adding in the table editors, 3-120
 in the Options menu (multiplexer), 3-8
 multiplexer, 3-8
 selecting an algorithm, 3-90
 conditional access (CA) identifier descriptor, 3-170
 conditional access descriptor, 3-163
 Configuration
 multiplexer. *See* Environment
 real-time multiplexer, saving, 3-260
 Reed-Solomon coding, 3-204
 Configuration file
 creating a new file, 3-33
 error injector, 3-229
 creating, 3-227
 example, 3-85
 multiplexer, 3-3, 3-32
 illustration, 3-4
 number of programs, 2-22
 opening an existing file, 3-33
 Configurations management, real-time multiplexer, 3-262
 Connecting to a real-time multiplexer server, 3-238
 Connecting to a remote multiplexer server, 3-238
 Constellation, MIP parameter, 3-58
 Contacting Tektronix, xvii
 content advisory descriptor, 3-187
 content descriptor, 3-172
 Controlling a transport stream file input, real-time multiplexer, 3-277
 Convolutional Interleaving Coding, 3-212
 Copying table items, table editors, 3-124
 copyright descriptor, 3-164
 Correcting errors, table editors, 3-129
 country availability descriptor, 3-173
 Create
 an MGT automatically, 3-112
 EIT time span, 3-115
 multiplexer, a transport stream file, 3-84
 table editors, a new table, 3-108
 Creating a new configuration file, multiplexer, 3-33
 Creating and editing a configuration file, 3-32

creating TMCC transport streams
 TMCC basic streams (S_TMCC), 3-218
 TMCC data streams (M_TMCC), 3-223
 Cursor
 position, 3-18
 timing, 3-18
 Cutting table items, table editors, 3-124
 CVCT
 definition, Glossary-1
 real-time multiplexer, 3-270
 table editors, parameters, 3-160

D

Data elementary stream
 adding to the multiplex, 3-51
 multiplexer, icon, 3-14
 Data format, data elementary stream, 3-51
 data stream alignment descriptor, 3-164
 DCT, definition, Glossary-1
 decimal/hexadecimal views, OpenMux, 3-249
 Decoder testing, 3-191
 Decoding
 DVB, 3-199
 menu, 3-206
 Definition command button, Packet Jitter, 3-198
 DeInterleaver command, 3-207
 Delete
 button, 3-35
 MIP, 3-61
 MIP icon, 3-24
 multiplexer, 2-18
 button, 3-6
 EIT instances, 3-73
 hierarchy items, 3-36
 real-time multiplexer
 output, 3-289
 transport stream and program inputs, 3-278
 table editors
 removing table items, 3-124
 table sections, 3-114
 time spans, 3-115
 demonstration license, OpenMux, 3-234
 Descriptors
 adding, 2-32
 selection, 2-32

descriptors

- AC-3 audio, 3-185
- audio stream, 3-163
- bouquet name, 3-169
- CA (conditional access) identifier, 3-170
- cable delivery system, 3-171
- caption service, 3-186
- component, 3-171
- component name, 3-186
- conditional access, 3-163
- content, 3-172
- content advisory, 3-187
- copyright, 3-164
- country availability, 3-173
- data stream alignment, 3-164
- editing, 3-123
- extended channel name, 3-187
- extended event, 3-173
- frequency list, 3-174
- hierarchy, 3-164
- IBP, 3-165
- ISO 639 language, 3-165
- linkage, 3-174
- local time offset, 3-175
- maximum bitrate, 3-165
- mosaic, 3-176
- multilingual bouquet name, 3-176
- multilingual component name, 3-176
- multilingual service name, 3-176
- multiplex buffer utilization, 3-166
- network name, 3-177
- NVOD (near video on demand) reference, 3-177
- parental rating, 3-178
- private data (indicator), 3-166
- private data specifier, 3-178
- program identifier, 3-187
- registration, 3-166
- satellite delivery system, 3-179
- service, 3-179
- Service ID, table file associations, 3-141
- service list, 3-180
- service location, 3-189
- service move, 3-180
- short event, 3-181
- short smoothing buffer, 3-181
- smoothing buffer, 3-166
- STD (system target decoder), 3-167
- stream identifier, 3-181
- stuffing, 3-181
- system clock, 3-167
- target background grid, 3-167
- telephone, 3-182

- teletext, 3-182
- terrestrial delivery system, 3-183
- time shifted event, 3-183
- time shifted service, 3-184
- time shifted service location, 3-190
- user, 3-184
- video stream, 3-168
- video window, 3-169
- Digital Video Broadcast. *See* DVB
- Directories, multiplexer defaults, 3-28
- disabling the OpenMux license message, 3-235
- Display the OpenMux Spy view, real-time multiplexer, 3-252
- DIT, definition, Glossary-1
- DLT, definition, Glossary-2
- Dolby Digital (AC-3) Audio Stream Analyzer, description, 1-8
- Dongle. *See* Software key
- Drop down selection box
 - table editor edit view, 3-98
 - table editors, 3-121
- DTS, definition, Glossary-2
- Duration gauge
 - coding and decoding, 3-200
 - multiplexer, 2-8, 3-8
- DVB
 - changing environment options, 3-21
 - definition, Glossary-2
 - multiplexer environment option, 2-40
 - multiplexer file selection dialog box, 2-41
 - real-time multiplexer, 3-267
 - scrambling algorithm, 3-90
- DVB ATSC multiplexer, description, 1-1
- DVB Channel Coder Decoder, description, 1-3
- DVB Coding and Decoding, 3-199-3-214
 - coding menu, 3-202
 - convolution interleaving, 3-212
 - decoding, 3-206
 - Help menu, 3-210
 - Reed-Solomon, 3-212
- DVB compliant files, 3-207
 - creating, 3-202
- DVB File Selection dialog box, 3-55
- DVB IRD, definition, Glossary-2
- DVB Table Editor
 - description, 1-2
 - using, 3-93
- DVB-SI, definition, Glossary-2
- DVB-T Mega-frame, 3-56
 - changing environment options, 3-23
- Dynamic SI, changing environment options, 3-27

- Dynamic view
 - multiplexer button, 3-7
 - multiplexer window, 3-16
 - switching to, 2-25
 - using (multiplexer), 3-16
- Dynamic view command button, multiplexer, 3-7

E

ECM

- definition, Glossary-2
- multiplexer
 - adding, 3-91
 - icon, 3-14
- selecting an ECM file, 3-92

Edit menu

- multiplexer, 3-6
- table editors, 3-99

Edit view window, text and drop-down boxes, 3-121, 3-123, 3-143

Edit window

- features, 3-98
- table editors, 3-97

Editing

- error injector, configuration file, 3-228
- MIP parameters, 3-56
- multiplex parameters, 3-37
- multiplexer
 - ARIB periods, 3-40
 - DVB SI parameters, 3-39
 - ETT, 3-67
 - hierarchy items, 3-34
 - MIP parameters, 3-57
 - NIT parameters, 3-42
 - PAT table parameters, 3-41
 - PMT parameters, 3-42
 - program parameters, 3-45
 - PSI table parameters, 3-38
 - PSIP parameters, 3-66
 - PSIP periods, 3-40
 - PSIP tables, 3-62
 - table parameters, 3-52
 - TDT values, 3-54
- real-time multiplexer, PSI-SI-PSIP tables, 3-273
- table editors
 - parameters, 3-123
 - table parameters, 3-121
- table item parameters, 3-143

EIT

- association with NIT and SDT, 3-139
- definition, Glossary-2
- DVB table parameters, 3-146
- event information table, 3-63
- event information table for DVB, 3-21
- file naming restrictions for PSIP EIT, 3-111
- multiplexer
 - adding and editing, 3-66
 - associating files to icons, 3-68
 - icon, 3-12
- multiplexer dialog box, 3-67
- PSIP table parameters, 3-156
- table editors
 - associating channels and events, 3-136
 - creating, deleting, and moving among, 3-115
 - parameters for DVB events, 3-147

Elementary stream

- audio elementary stream initial delay, 3-50
- files, 2-3
 - FTP site, 2-5
- in PMT, 3-153
- maximum in multiplexer transport stream, 1-1
- multiplexer
 - adding, 2-10
 - adding to a program, 3-46
 - initial delay, 3-19
- undefined, 3-84
- video elementary stream initial delay, 3-48

Elementary stream rate

- audio elementary stream, 3-50
- video elementary stream, 3-48

EMM

- definition, Glossary-2
- multiplexer
 - adding to a CAT, 3-90
 - icon, 3-11
- enabling the OpenMux demonstration period, 3-234
- End, locked application, A-1
- End task, A-1
- Ending, locked application, A-1
- Energy Dispersal
 - coding, 1-3, 3-202, 3-211
 - coding command, 3-203
 - removal command, 3-208

Environment

- ARIB, 3-25
- ATSC, 3-26
- changing, 2-40
- DVB, 3-21
- DVB-T Mega-frame, 3-23
- Dynamic SI, 3-27
- multiplexer, 3-20
 - scrambling, 3-90
- multiplexer defaults, 3-31
- real-time multiplexer, changing output environment, 3-274
- saving and restoring options, 3-29

EPG, definition, Glossary-3

Error

- correcting in the table editor, 3-129
- creating using the error injector, 3-225
- failure in socket connection, OpenMux, 3-234
- real-time multiplexer
 - messages about PID types, 3-289
 - messages about the audio component, 3-287
 - messages about the video component, 3-286
- table editors
 - error IDs, 3-131
 - message headers, 3-131
 - message types, 3-130
 - message window, 3-127
 - printing, 3-129
 - types of analyses, 3-130
 - using online help to interpret, 3-131
 - using the message window, 3-128

Error Injector, 3-225-3-232

- description, 1-3
- operators, 3-226
- tutorial, 3-227

estimated stop time, multiplexer dynamic view, 3-17

ETM, definition, Glossary-2

ETM ID, use to associate events and messages, 3-138

ETT

- associating messages to events, 3-136
- definition, Glossary-2
- extended text message, 3-63
- file naming constraints, 3-111
- multiplexer
 - adding, 3-76
 - icon, 3-13
- table editors
 - associating messages and events, 3-138
 - create, delete, and moving among, 3-115
 - parameters, 3-157

Event, adding in the table editors, 3-120

Event ID

- associating VCTs and EITs, 3-136
- managing event in a transport stream, 3-139

Event parameters, EIT, 3-147

Events, associating messages with, 3-138

Exit, applications, 1-16

Expand/Collapse hierarchy

- global view, 3-135
- multiplexer, 3-15
- table editors, 3-96

Expert client, overview, 1-5

extended channel name descriptor, 3-187

extended event descriptor, 3-173

F

Faliure in socket connection, OpenMux, 3-234

Field encoding changes, 3-46

File menu

- coding and decoding, 3-201
- multiplexer, 3-6
- Packet Jitter, 3-192
- real-time multiplexer, 3-247
- table editors, 3-98

File names, PSIP EIT files constraints, 3-111

Filtered PID dialog box, 3-281

Filtering PIDs, real-time multiplexer, 3-281

Find, Edit menu selection (DVB table editor), 3-125

First time operation, ix, 1-14

frame, definition, Glossary-3

Frame encoding changes, 3-46

frame size, TMCC basic streams, 3-222

frequency list descriptor, 3-174

Frequency offset, MIP functions, 3-60

FTP site, elementary stream files, 2-5

Functions of toolbar buttons, table editors, 3-102

G

G.703, multiplex rate, 3-37

General license password, 1-13, B-7

Generate button (Go), multiplexer, 3-7

Generating a multiplex, 3-84

Generation menu, coding and decoding, 3-208

Global multiplex start time, 3-19

- multiplexer dynamic view, 3-17

Global view, 3-132
 collapsing and expanding tables, 3-135
 opening, 3-133
 opening without saving existing files, 3-133
 selecting files to display, 3-134
 using in the DVB table editor, 3-139
 using in the PSIP table editor, 3-136

Go button, multiplexer, 3-7

Green, multiplex rate gauge, 3-9

Guard interval, MIP parameter, 3-59

H

Hardware installation, ix

HASP, 2-1

Help menu
 DVB Channel Coding and Decoding, 3-210
 multiplexer, 3-8
 Packet Jitter, 3-198
 real-time multiplexer, 3-250
 table editors, 3-101

Hexadecimal, text in table editors, 3-121

Hiding multiplexer icons, 3-15

Hiding table elements, Global view, 3-135

Hierarchic view
 multiplexer, 2-9, 3-10
 adding a MIP icon, 3-57
 adding and editing items, 3-34
 button, 3-7
 icons, 3-11
 real-time multiplexer, 3-256
 collapse/expand hierarchy, 3-256
 table editors, description, 3-96

Hierarchy
 collapsing/expanding, multiplexer, 3-15
 MIP parameter, 3-58

hierarchy descriptor, 3-164

I

IBP descriptor, 3-165

Icons
 multiplexer, 3-11
 real-time multiplexer, 3-252
 sizes, OpenMux, 3-249
 table editors, hierarchic and global views, 3-104

Information view, real-time multiplexer, 3-283

Initial delay, data elementary stream, 3-51

Inner Coder, 1-3

Input File dialog box, real-time multiplexer, 3-275

Input menu, real-time multiplexer, 3-247

Inputs

error injector, 3-225

multiplexer, 3-4

real-time multiplexer, 3-233, 3-263
 adding elementary stream program, 3-285
 controlling transport and elementary streams, 3-277
 deleting elementary stream program components, 3-279
 deleting transport and elementary streams, 3-278
 elementary stream program, 3-284
 elementary stream program limitations, 3-284
 filtering, 3-281
 icon description, 3-254
 managing inputs, 3-263
 monitoring, 3-283
 PSI-SI-PSIP, 3-264
 status, 3-254
 transport stream file, 3-275

Insert section, table editor, 3-114

Installation, 1-9
 hardware, ix

Installing Option CA, 3-89

Inter-analyses, 3-126, 3-130

Interleaver
 coding, 1-3
 command, 3-205
 file type required, 3-205

Intra-analyses, 3-126, 3-130

ISDB-S, definition, Glossary-3

ISO 639 language descriptor, 3-165

ISO/IEC 1318-1, included as a help file on disc, 3-125

J

Jitter
 define, 3-193
 offset, 3-194
 sine, 3-195
 square, 3-194
 type, 3-194

Jitter Adder, description, 1-3

Jitter Adder menu, 3-193

K

Key, software, 1-12

L

- License manager, entering your password, 1-13, B-7
- Limitations
 - error injector, 3-227
 - multiplexer, 1-1
 - real-time multiplexer, 3-234
 - elementary stream program inputs, 3-284
- linkage descriptor, 3-174
- Loading environment options, 3-29
- local time offset descriptor, 3-175
- Locked application, A-1
- Logging on, 1-15

M

- M_TMCC, definition, Glossary-3
- M_TMCC streams
 - data fields, 3-217
 - defined, 3-215
- Managing streams, services, and events, PSIP table editor, 3-136
- Manual Reset, A-1
- Master client, overview, 1-4
- maximum bitrate descriptor, 3-165
- Maximum delay, MIP parameter, 3-58
- Maximum number of table sections, table editors, 3-100
- Mega-frame, definition, Glossary-3
- Mega-frame initialization packet (MIP)
 - adding and editing parameters, 3-56
 - definition, Glossary-3
- Menus
 - coder/decoder, 3-201
 - jitter adder, 3-192
 - multiplexer, 3-6
 - real-time multiplexer, 3-247
 - table editors, 3-98
- Messages, channel and event ETT, 3-138
- MGT
 - definition, Glossary-3
 - master guide table, 3-63
 - multiplexer, icon, 3-13
 - real-time multiplexer, 3-270
 - table editors, parameters, 3-157
 - wizard, 3-112
- Minimum requirements, 1-9

MIP

- adding functions to, 3-59
- functions dialog box, 3-59
- functions explained, 3-60
- multiplexer, icon, 3-13
- parameters explained, 3-58
- removing from configuration file, 3-61

MIP parameters, dialog box, 3-57

Mode, MIP parameter, 3-58

Modify, real-time multiplexer, PSI-SI-PSIP tables, 3-273

Monitoring an input, real-time multiplexer, 3-283

mosaic descriptor, 3-176

Moving

- among tables, 3-111
- the timing cursor, 3-18

MPEG2 DVB/ATSC Multiplexer, description, 1-1

MPEG-2 DVB/ATSC System Analyzer, description, 1-8

MTS200 Series applications, descriptions, 1-4

multilingual bouquet name descriptor, 3-176

multilingual component name descriptor, 3-176

multilingual service name descriptor, 3-176

Multiple string structure, 3-162

Multiplex

- cannot generate, 3-84
- global start time, 3-37
- icon, 2-9, 3-11
- overflow, 2-14
- overflow message, 3-57
- press ESC to stop generation, 3-84
- rate, 3-48
- rate gauge, 2-14
- rate gauge colors, 3-9
- rate overflow, 3-9
- real-time multiplexer, tutorial, 3-240
- real-time multiplexer inputs, 3-263

Multiplex allocation views, real-time multiplexer, 3-258

multiplex buffer utilization descriptor, 3-166

Multiplex menu, 3-84

- multiplexer, 3-7
- real-time multiplexer, 3-248

Multiplex window

- Dynamic view, 3-9
- Hierarchic view, 3-9

Multiplexer

- default environment settings, 3-31
- Hierarchic view, 2-9
- icon description and use, 3-11
- real-time multiplexer application window, 3-246

Multiplexer server

- connecting to remotely, 3-238
- quitting, 3-239
- saving configuration of, 3-260
- starting, 3-236

N

network name descriptor, 3-177

New button, multiplexer, 3-6

New table sections, creating, 3-114

Next

- button in the dynamic view, 3-18
- table editors, section, 3-114

NIT

- association with EIT and SDT, 3-139
- definition, Glossary-3
- editing in the multiplexer, 3-42
- multiplexer, icon, 2-9, 2-40, 3-12
- network information table, 3-21
- parameters extracted by the MIP, 3-58
- real-time multiplexer, 3-268
- table editors, parameters, 3-149
- transport streams in, 3-154

NIT and SDT association, 2-58

NT log on, user name and password, 1-15

Number of sections

- in table files, 3-113
- table editors, 3-115

NVOD, definition, Glossary-3

NVOD (near video on demand) reference descriptor,
3-177

O

Offset jitter, 3-194

Offset PTS

- audio elementary stream, 3-50
- video elementary stream, 3-48

Online help, using to interpret PSIP Table editor error
messages, 3-131

Open a Table, PSIP table editor dialog box, 3-134

Open button, multiplexer, 3-6

Open command, File menu, Packet Jitter, 3-192

Open command button, Packet Jitter, 3-198

opening an existing configuration file, multiplexer,
3-33

Opening existing tables, 3-109

OpenMux demonstration period, enabling and
disabling, 3-234

OpenMux Spy view, real-time multiplexer, 3-252

Operators, error injector, 3-226

Option CA (Conditional Access), installing, 3-89

Option menu, PSIP table editor, 3-101

Options menu

- multiplexer, 3-7
- real-time multiplexer, 3-249

Output

- error injector, 3-225
- multiplexer, 3-4
- real-time multiplexer, 3-234, 3-289
 - add, 3-289
 - change the multiplex rate, 3-289
 - changing environment, 3-274
 - remove, 3-289
 - stopping, 3-289

Output menu, real-time multiplexer, 3-248

Overflow, multiplex rate, 3-9

Overview

- Expert client, 1-5
- Master client, 1-4
- TMCC Configuration client, 1-7
- TMCC Expert client, 1-5

P

Packet Jitter, Help menu, 3-198

Packet Jitter application, 3-191

packet size, for the TMCC Combiner, 3-215

Parameters

- editing, 3-123
- MIP, 3-58
- table editors, 3-143
 - editing, 3-121

parental rating descriptor, 3-178

Password, B-7

- and user name, NT log on, 1-15
- changing, 1-15
 - emergency repair disk, 1-15
- for installing Option CA (conditional access), 3-89
- for installing software, 1-13

Pasting table items, table editors, 3-124

PAT

- definition, Glossary-4
- dialog box, 2-29
- editing, 2-29
- multiplexer
 - icon, 2-9, 3-11
 - parameters, 3-41
 - period. *See* PSI period
- real-time multiplexer, 3-266

Pattern

- composition motif, 3-209
- generation command, 3-208
- repetition, 3-209

PCR, 3-191

- definition, Glossary-4
- encoded automatically by multiplexer, 3-45

PCR Clock Selection, packet jitter, 3-193**PCR period, change with the multiplexer, 3-45****Performing analyses, table editors, 3-126****Periodic, MIP parameter, 3-58****PES, definition, Glossary-4****PES Packet Size**

- audio elementary stream, 3-50
- video elementary stream, 3-48

Phone number, Tektronix, xvii**PID, 3-193**

- definition, Glossary-4

PID allocation view, real-time multiplexer, 3-259**PID modification, using the multiplexer, 2-29****PLL, decoder design, 3-191****PMT**

- definition, Glossary-4
- descriptors, 2-31
- displaying sections in multiplexer, 2-31
- editing, 2-30
- editing with the multiplexer, 3-42
- elementary stream parameters in, 3-153
- multiplexer
 - icon, 2-9, 3-11
 - period. *See* PSI period
- real-time multiplexer, 3-266
- sections added automatically (multiplexer), 3-44
- table editors, parameters, 3-148

Popup menus, real-time multiplexer hierarchic view, 3-257**Power, MIP functions, 3-60****Power switch, 1-14****PRBS, 3-203, 3-211****Previous**

- button in the dynamic view, 3-18
- table editors, section, 3-115

Printing error messages, 3-129**Priority, MIP parameter, 3-58****Private data, MIP functions, 3-60****private data (indicator) descriptor, 3-166****private data specifier descriptor, 3-178****Product support, contact information, xvii****Program**

- adding, 2-21
- changing the starting time, 2-25
- elementary streams in a program, 2-22
- empty, 3-84
- multiplexer
 - adding, 3-44
 - dynamic view icon, 3-17
 - editing start delay, 3-45
 - icon, 2-9, 3-14
 - start delay, 3-19
 - timing relationships shown in the dynamic view, 3-17
- number in configuration file, 2-22
- start delay, 2-25

Program allocation view, real-time multiplexer, 3-258**Program and System Information Protocol. *See* PSIP****program identifier descriptor, 3-187****Program number vs program_number, multiplexer dynamic view, 2-25****Program paradigm, 3-266, 3-274**

- definition, Glossary-4

Program Specific Information. *See* PSI**Program Stream Analyzer, description, 1-8****Protection, software key, 1-10****PSI**

- definition, Glossary-4
- descriptors, 3-163
- editing, 2-27
- multiplexer, icon, 2-9, 3-11
- period dialog box, 2-28
- real-time multiplexer, 3-266
- table editors, tables, 3-94
- table parameters, 3-144

PSIP

- definition, Glossary-4
- descriptors, 3-185
- edit period parameters, 3-40
- managing events with source IDs, 3-136
- multiplexer
 - adding more icons to the hierarchy, 3-64
 - adding the environment, 3-26
- multiplexer icon, 3-13
- table editors, tables, 3-94
- table parameters, 3-155

PSIP events, associating extended text message with, 3-138**PSIP Table Editor**

- description, 1-2
- using, 3-93

PTS, definition, Glossary-4

Q

QPSK Modulating, coding, 1-3
 Quit command, File menu, Packet Jitter, 3-193
 Quitting applications, 1-16

R

Random jitter, 3-196
 Rate
 data elementary stream, 3-51
 multiplex calculation, 3-8
 multiplexer
 gauge, 2-14
 how calculated, 2-8
 specifying in multiplexer, 3-37
 Rate gauge, multiplexer, 2-8, 3-8
 Real-Time Analyzer, description, 1-4
 Real-time multiplexer
 connecting to a server, 3-238
 description, 1-3
 elementary stream program input, 3-284
 elementary stream program input limitations, 3-284
 input icon status, 3-254
 inputs, 3-233
 installing, 3-234
 limitations, 3-234
 output, 3-234
 PSI-SI-PSIP, 3-264
 server, 3-233
 transport stream file, 3-275
 tutorial, 3-240
 windows, views, and interface, 3-246
 Red, multiplex rate gauge, 3-9
 Reed-Solomon
 coded block size, 3-204
 coding, 3-212
 coding command, 3-204
 coding configuration, 3-204
 decoding command, 3-208
 size of block, 3-204
 registration descriptor, 3-166
 Remove
 a program from a transport stream file input, 3-279
 audio stream from a program input, 3-279
 DVB-T multiplex environment, 3-24
 Removing, copying, and pasting table items, table editors, 3-124
 Repair, software, B-1
 Requirements, software and hardware, 1-9
 Reset, A-1
 Restoring environment options, 3-29

RRT

definition, Glossary-4
 multiplexer, icon, 3-13
 rating region table, 3-63
 table editors, parameters, 3-159
 RS(204, 188), 3-212
 coding, 1-3
 RST
 multiplexer, icon, 3-12
 running status table, 3-22
 table editors, parameters, 3-150

S

S_TMCC, definition, Glossary-5
 S_TMCC streams
 defined, 3-215
 TMCC basic field descriptions, 3-216
 Sarnoff, video test sequences CD-ROM, 1-9
 Satellite broadcasting, 3-199
 coding, 1-3
 satellite delivery system descriptor, 3-179
 Save
 environment options, 3-29
 error injector, transport stream file, 3-230
 error injector configuration files, 3-229
 real-time multiplexer, configurations, 3-260
 table editors, 3-109
 Save All, table editors, 3-110
 Save As, table editors, 3-109
 Save button, multiplexer, 3-6
 Scrambling, 3-89
 in the Options menu (multiplexer), 3-8
 option in audio stream selection, 3-50
 option in video stream selection, 3-48
 scrambling a stream, 3-92
 selecting an algorithm, 3-90
 SDT
 association with EIT and NIT, 3-139
 definition, Glossary-4
 multiplexer, icon, 3-12
 real-time multiplexer, 3-268
 service description table, 3-21
 table editors, parameters, 3-150
 SDT and NIT association, 2-58
 SDTT, definition, Glossary-4
 Searching for table items (Find), DVB table editor, 3-125
 Section menu, table editors, 3-100

Sections

- creating, inserting, and deleting, 3-114
- describe/correspond to, 3-112
- moving among, 3-114
- number of in tables, 3-112

Security, Windows NT dialog box, A-1
Selecting, multiplexer

- a NIT, 3-43
- PSIP files, 3-64

Selection boxes, table editors, 3-98
Sequence Header, Video Stream dialog box, 3-48
Sequence header, option in video stream selection, 3-48
Service

- adding in the table editors, 3-120
- ID, managing events in a transport stream, 3-139
- SDT, table file associations, 3-141

service descriptor, 3-179
Service Information. *See* SI
service list descriptor, 3-180
service location descriptor, 3-189

- real-time multiplexer, 3-270

service move descriptor, 3-180
service name descriptor, real-time multiplexer, 3-268
Service support, contact information, xvii
Setting

- DVB multiplexer environment, 3-22
- elementary stream initial delay, 3-19, 3-50
- global multiplex start time, 3-19
- program start delay, 3-19, 3-45
- video stream initial delay, 3-48

Setup, hardware, ix
SFN, single frequency networks, 3-56
SFN (Single Frequency Network), definition, Glossary-5
short event descriptor, 3-181
short smoothing buffer descriptor, 3-181
Showing table elements, Global view, 3-135
Shutdown, computer, 1-16, A-1
SI

- adding and editing in the multiplexer, 3-52
- definition, Glossary-5
- descriptors, 3-169
- multiplexer, editing table period, 3-39
- multiplexer icon, 2-40, 3-12
- table editors, tables, 3-94
- table parameters, 3-144

SI tables present, warning (multiplexer), 3-22
Sine jitter, 3-195
SIT, definition, Glossary-5
Size of block, Reed-Solomon coding, 3-204
Slider bar, multiplexer dynamic view, 3-18
slot, definition, Glossary-5

smoothing buffer descriptor, 3-166

Software

- installation, 1-9
- key, 1-12
- reinstall, B-1
- repair, B-1

Software description

- ATSC (PSIP) Table Editor, 1-2
- Dolby Digital Audio Stream Analyzer, 1-8
- DVB Channel Coder and Decoder, 1-3
- DVB Table Editor, 1-2
- Error Injector, 1-3
- Jitter Adder, 1-3
- MPEG Audio Stream Analyzer, 1-8
- MPEG Video Stream Analyzer, 1-8
- MPEG2 DVB/ATSC System Analyzer, 1-8
- MPEG-2 DVB/ATSC Transport Stream Multiplexer, 1-1
- MTS200 Series Applications, 1-4
- Program Stream Analyzer, 1-8
- PSIP (ATSC) Table Editor, 1-2
- Real-Time Analyzer, 1-4
- Real-Time Multiplexer, 1-3
- stream player, 1-7
- stream recorder client, 1-7

Software key, 1-10, B-5
Software version, xii
Specifications, ix
Splice, adding to the configuration file, 3-52
Square jitter, 3-194
Standards conformed to (table editors)

- ATSC Doc A/65, 3-94
- Draft ETS 300 468, 3-94

Starting

- applications, 1-15
- multiplexer server, 3-236
- software installation, B-3

starting the TMCC Combiner, 3-219
Status bar

- multiplexer, 3-9
- real-time multiplexer, 3-251

STD (system target decoder) descriptor, 3-167
Stop, real-time multiplexer, output, 3-289
Stream, adding in the table editors, 3-120
stream identifier descriptor, 3-181
Stream Player, description, 1-7
Stream Recorder, description, 1-7
STT

- definition, Glossary-5
- multiplexer, icon, 3-13
- real-time multiplexer, 3-271
- system time table, 3-63
- table editors, parameters, 3-159

stuffing descriptor, 3-181
 super frame, 3-222
 definition, Glossary-5
 Suppress service, real-time multiplexer, 3-279
 Sync byte, 3-203
 system clock descriptor, 3-167
 system target decoder (SDT) descriptor, 3-167

T

Table, real-time multiplexer, PSI-SI-PSIP, 3-265
 Table analyses, performing in the table editor, 3-126
 Table editor, command buttons, 3-102
 Table editors, starting from the multiplexer, 2-31, 3-95
 Table file associations
 DVB table editor, 3-139
 PSIP table editor, 3-136
 Table Items, 3-116
 adding, 3-117
 adding a stream, service, or event, 3-120
 adding descriptors, 3-122
 collapsing and expanding in the Global view, 3-135
 editing, 3-121
 items you can add to tables, 3-118
 removing, copying, and pasting, 3-124
 searching for (Find, DVB only), 3-125
 Table parameter values, values extracted from the multiplexer, 3-98
 Table sections
 creating, inserting, and deleting, 3-114
 describe/correspond to, 3-112
 in the hierarchic view, 3-97
 moving among, 3-114
 target background grid descriptor, 3-167
 Task Manager, A-1
 TDT
 multiplexer
 adding, 3-54
 creating, 2-54
 icon, 3-12
 setting parameters, 2-42
 setting the period, 2-54
 real-time multiplexer, 3-269
 time and date table, 3-22
 Technical support, contact information, xvii
 Tektronix, contacting, xvii
 telephone descriptor, 3-182
 teletext descriptor, 3-182
 Terrestrial ATSC, multiplexer environment option, 3-26
 terrestrial delivery system descriptor, 3-183

Text boxes
 table editor edit view, 3-98
 table editors, 3-121
 Time and Date Table, multiplexer dialog box, 3-54
 Time offset, MIP functions, 3-60
 time shifted event descriptor, 3-183
 time shifted service descriptor, 3-184
 time shifted service location descriptor, 3-190
 Time spans
 creating, deleting, and moving among, 3-115
 ETT and EIT must be the same, 3-138
 PSIP table editor menu, 3-100
 shown in the global view, 3-137
 Timing
 cursor handle, 2-26
 diagram showing relationships, 3-20
 multiplex global start time, 3-37
 multiplexer, cursor, 3-17
 relationships shown in the dynamic view, 3-9, 3-16
 viewing and setting offsets, 3-19
 TMCC, definition, Glossary-5
 TMCC Combiner
 buttons, 3-218
 configuring transitions, 3-222
 creating a TMCC basic stream, 3-218
 defining properties for an S_TMCC stream, 3-221
 input for a TMCC basic stream, 3-215, 3-220
 input for a TMCC data stream, 3-215
 limitations, 3-215
 minimum requirements, 3-215
 properties window described, 3-222
 S_TMCC fields, 3-216
 starting, 3-219
 TMCC Configuration client, overview, 1-7
 TMCC Expert client, overview, 1-5
 Toggle management, real-time multiplexer, 3-264
 Toolbar
 multiplexer, 3-6
 Packet Jitter, 3-198
 real-time multiplexer, 3-250
 table editors, 3-102
 TOT
 multiplexer, icon, 3-12
 table editors, parameters, 3-151
 time offset table, 3-22
 transitions, 3-222
 Transmission errors, 1-3, 3-191
 transmission mode, TMCC Combiner, 3-222
 Transmitter functions, in the MIP, 3-60
 Transport Packet command, 3-209

Transport stream

- adding in the table editors, 3-120
- creating errors, 1-3
- generating with multiplexer, 3-84
- generating with the real-time multiplexer, 3-233
- jitter adder, 3-191
- multiplexer
 - generating, 2-38
 - item icons in hierarchic view, 3-10
 - naming, 3-84
 - table editors, parameters in NIT and BAT, 3-154

Transport stream file, 2-19

- creating using the multiplexer, 2-19
- error injector, generating, 3-230
- generating with the error injector, 3-230
- jitter adder, 3-191
- multiplexer, 3-3

Transport stream ID, managing events in a transport stream, 3-139

TS. *See* Transport Stream

TSDT

- multiplexer
 - adding, 3-35
 - icon, 3-11
- table editors, parameters, 3-152

Tutorials

- error injector, 3-227
- multiplexer
 - complex DVB, 2-39
 - complex MPEG-2, 2-21
 - simple, 2-7
- real-time multiplexer, 3-240

TVCT

- definition, Glossary-5
- real-time multiplexer, 3-270
- table editors, parameters, 3-160

Tx identifier, MIP functions, 3-60

Types of table analyses, 3-130

U

URL

- for ISO, ETSI, and ATSC, 3-125
- Tektronix, xvii

user descriptor, 3-184

user name and password, NT log on, 1-15

Using the DVB Channel Coder/Decoder, 3-199

Using the DVB, PSIP, and ARIB Table Editors, 3-93

Using the Error Injector, 3-225

Using the error message window, 3-128

Using the Jitter Adder, 3-191

Using the Multiplexer, 3-3

Using the Real-Time Multiplexer, 3-233

V

VCT

- definition, Glossary-5
- multiplexer, icon, 3-13
- real-time multiplexer, 3-270
- table editors
 - managing services, streams, and events, 3-136
 - parameters, 3-160
- virtual channel table, 3-63

Version, software, xii

Video elementary stream

- adding to multiplexer configuration file, 2-11
- adding to the multiplex, 3-47
- initial delay parameter, 3-48
- multiplexer, icon, 3-14
- selecting, 2-11

Video splice

- adding to the configuration file, 3-52
- multiplexer icon, 3-14

Video Stream Analyzer, description, 1-8

video stream descriptor, 3-168

video window descriptor, 3-169

View menu

- multiplexer, 3-7
- real-time multiplexer, 3-249

Views

- OpenMux Spy, 3-252
- real-time multiplexer
 - hierarchic, 3-256
 - multiplex allocation, 3-258

Viterbi

- coding, 1-3, 3-213
- file type expected, 3-206
- decoding, 3-205

W

Warning

- delete SI tables, 3-30
 - messages
 - interpreting error messages, 3-130
 - using the message window, 3-128
 - multiplex overflow options, 3-57
 - SI tables present (multiplexer), 3-22
 - SI tables suppressed, 3-29
 - TDT not present, 3-27
- Web site address, Tektronix, xvii

Window menu, real-time multiplexer, 3-250

Windows, real-time multiplexer, 3-246

Windows NT

- initialization, 1-15
 - security dialog box, A-1
- Wizard, using, 3-112

Y

Yellow, multiplex rate gauge, 3-9

